



Turun yliopisto
University of Turku

STILL BELIEVING IN VIRTUAL WORLDS:
A DECOMPOSED APPROACH

Jani Merikivi



Turun kauppakorkeakoulu
Turku School of Economics

**STILL BELIEVING IN VIRTUAL WORLDS:
A DECOMPOSED APPROACH**

Jani Merikivi

Sarja/Series A-5:2013



Turun kauppakorkeakoulu
Turku School of Economics

Custos: Adjunct Professor Jussi Puhakainen
Turku University of Applied Sciences

Supervisors: Adjunct Professor Jussi Puhakainen
Turku University of Applied Sciences

Pre-examiners: Docent Anssi Öörni
Aalto University

Associate Professor Robin Teigland
Stockholm School of Economics

Opponent: Docent Anssi Öörni
Aalto University

Copyright Jani Merikivi & Turku School of Economics

ISBN 978-952-249-311-8 (print) 978-952-249-312-5(PDF)
ISSN 0357-4652 (print) 1459-4870 (PDF)

Publications of Turku School of Economics, Series A

Suomen yliopistopaino Oy – Juvenes Print, Turku 2013

ACKNOWLEDGEMENTS

My dissertation is the result of an enjoyable and intriguing foray into virtual worlds, and like any other social adventure, it was never the work of any one person alone. Therefore, to everyone who made this journey with me, I would like to extend my most heartfelt gratitude for your encouragement and dedication in completing this dissertation.

Just as behind every great team there is a great manager, so behind my dissertation is an accomplished supervisor. Adjunct Professor Jussi Puhakainen, I am greatly indebted to you for your continuous support on my research. Your immense knowledge and patient guidance have been of incomparable value in the course of this dissertation. Just as importantly, however, you have let me discover my own course yet kept me from tilting at windmills. Without your experience and intelligence this study in its current form would never have come to fruition.

There are two other benignant managers I am equally obliged to. Professors Hannu Salmela and Tommi Hoikkala, I warmly thank you for providing me with your all-embracing assistance throughout my entire research journey.

I would also like to express my appreciation and acknowledgement to Assistant Professor Anssi Öörni from Aalto University for his time and efforts acting as both the pre-examiner and the opponent of my dissertation. My sincere thanks go also to Associate Professor Robin Teigland from the Stockholm School of Economics for taking an interest in and performing a thorough review of the dissertation. Your insightful and constructive questions, comments and suggestions greatly helped me improve the quality of the dissertation in both content and its formal aspects. You made my dissertation worth the readers' time.

I wish to thank Professor and the Dean of Turku School of Economics, Markus Granlund, and the faculty of Information Systems Science for giving me the permission to commence this dissertation in the first instance and to conduct the necessary research work. I would like to extend my sincere gratitude and appreciation especially to the following. The faculty heads, Professors Hannu Salmela, Reima Suomi, and Jukka Heikkilä, thank you for all of your input and commitment. Dear colleagues and members of the faculty, Matti Mäntymäki, Hongxiu Li, Timo Kestilä, Kai Kimppa, Timo Leino, Timo Lainema, Jonna Järveläinen, Eija Koskivaara, Ari Helin, and Markku Tuomola, I owe you a debt of recognition for being truly accommodating and helpful

with my questions. In addition, Secretary Birgit Haanmäki and library amanuensis Päivi Kanerva for all your help in putting my dissertation through its last bustling stages.

Then there are two other important work communities I am greatly indebted to. I want to thank the Finnish Youth Research Society for the wonderful kickstart to my research career. I could not have asked for more. Tommi Hoikkala, Leena Suurpää, Tanja Konttinen, Sami Myllyniemi, Minna Laasala, Minna Laukkanen, Kaisa Vehkalahti, Vappu Helmisaari, Heidi Villikka, Tarja Tolonen, Mikko Salasuo, Antti Kivijärvi, Anni Ojajärvi, Veronika Honkasalo, and Sofia Laine, thank you very much for being there with me. Mikko, my particular thanks go to you for talking me into my very first research project and for encouraging me to further pursue a career in research. You are a true champion on and off the field.

Members of the Turku Centre for Computer Science, I could not have felt more welcome and comfortable working with you. Hannu Tenhunen, Tapio Salakoski, Johan Lilius, Ion Petre, Irmeli Laine, Tomi Mäntylä, Ilona Tuominen, Outi Tuohi, Matti Mäntymäki, Hongxiu Li, Eeva Heiro, Najmul Ismail, José Teixeira, and Olli Sjöblom, please accept my sincere gratitude for making me feel at home. Hongxiu, I wish to specifically thank you for all your support and help.

I want to deliver my gratitude to the co-authors of the articles that accompany this dissertation. I am deeply obliged to Matti Mäntymäki with whom I have shared these years and worked together writing research articles. Matti, we have made a strong team. Also, I would like to extend my thankfulness to my other talented co-authors: particularly to Tibert Verhagen, but no less to Frans Feldberg, Risto Rajala, Bart van den Hooff, Selmar Meents, Erik Swen, Leena Tuuttila, Tero Huttunen, Päivi Timonen, Tomi Kiilakoski, Antti Kivijärvi, Anu Gretschel, Sofia Laine, Mirja Määttä, and Tarja Tolonen. It has been my honor to work with you all.

I wish to thank the people at the city of Helsinki youth department, especially Lasse Siurala, Suvi Kuikka, Leena Ruotsalainen, Leena Louhivuori, Tero Huttunen, Sebastian Sihvola, Leena Tuuttila, and Mimmi Mäkinen. I am indebted to you for all the trust you gave me at the early stages of my research career. Sebastian, I appreciate you for offering me an interesting research project and for familiarizing me with other virtual world researchers. (Vili Lehdonvirta, Mikael Johnson, and Minna Ruckenstein, thank you for your collaboration.) If it were not for your endless efforts and connections, there would certainly be a few less empirical studies on virtual worlds today.

I would like to acknowledge the participation, co-operation and helpful assistance of those working (or having worked) at and having a continuing interest in Sulake. My express thanks go to Sulka Haro, Marjoriikka Ylisiurua,

Heini Kaihu, Mikael Thuneberg, and Aino Luode. I also wish to extend my recognition to all the anonymous respondents of my research questionnaire for their willingness to go through it and answer the questions to the best of their knowledge.

For financial support I am indebted to Turku School of Economics Supporting Fund, Finnish Youth Research Society, Foundation for Economic Education, the Marcus Wallenberg Foundation, and Turku Centre for Computer Science. I want also to convey my gratitude to Ministry of Education and Culture for their assistance; in particular, Kimmo Aaltonen, Olli Saarela, and Georg Henrik Wrede.

Viljami and Kathleen Nykänen, thank you for putting a painstaking effort into proof-reading the final version of my dissertation for English style and grammar, both correcting and offering valuable suggestions for improvement. Not only have you improved my dissertation but also helped me learn from you while rewriting it. Thank you for your assistance and friendship.

Finally, I would like to give my sincerest thanks to my father and sister. Education pays off. I also owe a great deal of thanks to my parents-in-law, Matti and Ulla Ruohonen, who have stood by me in several ways. Whether babysitting or reading through my dissertation, I have always been able to count on them. But it is my wife and family I am most indebted to. Thank you for your unconditional love and constant support. Johanna, Enni, Eevi, and Heikki, I will forever be grateful to you for making this happen. Huomenna isä laittaa aamiaiseksi pannukakkuja ja jäätelöä.

Turku, May 2013

Jani Merikivi

TABLE OF CONTENTS

1	INTRODUCTION	11
1.1	Virtual worlds for continual use	11
1.2	Aim of the study and research question	13
1.3	Research set up and organization	15
2	THEORETICAL BACKGROUND	21
2.1	Virtual world attributes	21
2.2	Decomposed theory of planned behavior	22
2.3	Adapting DTPB to VW domain	27
2.4	Decomposing attitudinal, normative, and control beliefs	32
3	METHOD AND RESULTS.....	37
3.1	Positivist paradigm	37
3.2	Survey method.....	38
3.3	Implementation process.....	40
3.4	Data analysis.....	43
3.5	Results of the articles	47
4	DISCUSSION AND CONCLUSION.....	51
4.1	Key findings	51
4.2	Implications for theory	53
4.3	Implications for practice.....	56
4.4	Limitations and future research.....	57
4.5	Conclusion.....	59
	REFERENCES	61
	APPENDICES	81
	Appendix 1 Overview of IS adoption theories and models	81
	Appendix 2 Title page of the online questionnaire.....	83
	Appendix 3 Scales and measures in English (and Finnish)	84

Appendix 4 Convergent validity (article 2)	86
Appendix 5 Convergent validity (article 3)	86
Appendix 6 Convergent validity (article 4)	88
Appendix 7 Discriminant validity (article 2)	88
Appendix 8 Discriminant validity (article 3)	89
Appendix 9 Discriminant validity (article 4)	89

LIST OF ATTACHED PUBLICATIONS

Research article 1: Merikivi, J. – Mäntymäki, M. (2009) Explaining the Continuous Use of Social Virtual Worlds: An Applied Theory of Planned Behavior Approach. <i>Proceedings of the 42nd Annual Hawaii International Conference on System Sciences</i> , Hawaii, 5.-8.1.2009	91
Research article 2: Merikivi, J. (2009) What Habbo Goers Do in Practice? Decomposing Attitudinal Beliefs. <i>17th European Conference on Information Systems</i> , Verona, Italy, 8.-10.6.2009	103
Research article 3: Mäntymäki, M. – Merikivi, J. – Verhagen, T. – Feldberg, F. – Rajala, R. (in review) Still there? Understanding the continued use of virtual worlds. Unpublished manuscript.....	119
Research article 4: Merikivi, J. – Verhagen, T. – Feldberg, F. (2012) Having belief(s) in social virtual worlds: A decomposed approach. <i>New Media & Society</i> . < http://nms.sagepub.com/content/early/2012/11/26/1461444812466719.full.pdf+html >, retrieved 4/26, 2013.	154

LIST OF FIGURES

Figure 1	Research gap, improvements and contribution areas	14
Figure 2	Research timeline	15
Figure 3	Research design	16
Figure 4	Association between the original research articles	17
Figure 5	Theory of planned behavior	23
Figure 6	The original DTPB.....	26
Figure 7	The overall DTPB-based model viewing the adopted constructs and their relations	35
Figure 8	Empirical design	39
Figure 9	A snapshot of the Habbo Hotel lobby.....	41
Figure 10	An integrated model for continual VW use intention.....	49
Figure 11	Summary of theoretical implications	55

LIST OF TABLES

Table 1	Organization of the study.....	19
Table 2	Empirical post-adoption studies on VWs	28
Table 3	Auxiliary theories.....	31
Table 4	Summary of the adopted constructs.....	36
Table 5	Respondent information.....	44
Table 6	Responses per article.....	45
Table 7	Measurement model fit indices (articles 2 and 3).....	46
Table 8	Answers to the research questions	52

1 INTRODUCTION

1.1 Virtual worlds for continual use

Virtual worlds (VWs¹), defined as computer-simulated environments inhabited by multiple users in the form of avatars (e.g., Bainbridge 2007; Chesney, Chuah & Hoffmann 2009; Hua & Haughton 2009), are an intense reality. Originally, these avatar-centric environments were simple text-based online adventures, capable of serving only a handful of users (Bartle 2004; Taylor 2006); but unlike video games, VWs persisted even when an individual user logged out or quit using the system (Bell 2008, 4).

Following the advent of the World Wide Web (WWW), the increased broadband capability and the growing proliferation of home computers allowed for more users to inhabit VWs. Along with improved computer graphics quality, VWs advantageously turned to a graphical interface, which no longer illustrated a mere background but also provided an immediate and immersive user experience. VW users became imbued with a strong sense of community (e.g., Kohler, Füller, Matzler & Stieger 2011; Lombard & Ditton 1997). Meanwhile, VWs became more focused on both pleasurable and useful activities. This led them to grow from their original use for mere role-playing to socialization and user-driven system manipulation, making VWs more suitable for different use-contexts of daily living (see Steinkuehler & Williams 2006). Today, VW users are, for example, able to attend in virtual lectures and workshops, trade in-world currency that users buy in exchange for real money or design and sell virtual clothes, furniture, and real estate.

¹ A VW consists of software and hosting servers that run the software. A terminal device, such as personal computer, tablet computer, or smart phone, is connected to one of these hosting servers through the Internet.

Given the many different developments mentioned above, it comes as no surprise that VWs have reached out to a mass-market audience. kZero (2012), a consulting company active in the VW domain, reported in May 2012 that there was a total of over 1.9 billion user accounts. Unfortunately, total accounts are not fully comparable to continual use – that is, sustained and regular user traffic, which is a key to the survival of online service operators (Kim & Son 2009). In a fiercely competitive industry, such as VWs, this is far from self-evident.² Instead of making it to the “slope of enlightenment” at which true benefits are beginning to hit (Wasko, Teigland, Leidner & Järvenpää 2011, 645), VWs have seen a downturn in their user bases (Zhou, Fang, Vogel, Jin & Zhang 2012). For example, Habbo Hotel, the largest VW for teenagers, lowered its calculations of monthly users by more than half from last year, the estimate now being at around 5 million (Sulake Corporation 2012; Takahashi 2011). The collapse in user base has forced the VW operator to lay off up to two-thirds (60 workers) of its personnel in Finland (Meyer 2012). Another VW operator, Gaia Online, a competitor to Habbo Hotel, has also cut 20 percent (20 employees) of its workforce to respond to rising competition (Takahashi 2010). Hence, we believe that understanding how to retain existing VW users (Goel, Johnson, Junglas & Ives 2011; Mäntymäki & Salo 2011) has become an important research avenue.

While the existing research on VWs provides numerous different perspectives³, including those of examining conditions for initial acceptance (e.g., Fetscherin & Lattermann 2008; Fuller 2007; Holsapple 2007; Hua & Houghton 2009), it remains relatively silent on which antecedents and to what extent they drive continual VW use. Further, previous studies have also fallen short on empirically examining both indirect and direct effects of these antecedents on continual VW use. We find the approach important since such an examination clarifies the decision-making process an individual goes through when using VWs subject to permanent social changes (see Chaturvedi, Dolk & Drnevich 2011).

² According to kZero (2012), around 900 VWs exist in the market, indicating that VWs nearly doubled in one year.

³ For a review of various research perspectives, see Mennecke et al. (2008).

In bridging these gaps and responding to calls for combining the antecedents into one theoretical structure (Schwarz, Schwarz, Jung, Pérez-Mira & Wiley-Patton 2012), we propose a research model based on the decomposed theory of planned behavior (DTPB) (Taylor & Todd 1995a). DTPB is selected over other information system (IS) adoption theories and models as it enables us to investigate the evaluation components (i.e., attitude, subjective norm, and perceived behavioral control) and decompose the antecedents to continual VW use into attitudinal, normative, and control beliefs. Attitudinal beliefs are assessments about the likelihood of an individual's behavioral consequences of using a system; normative beliefs refer to an individual's perceptions about using a system in relation to the opinion and impact of others; and control beliefs concern an individual's perceptions about the control they have in using a system (Fishbein & Ajzen 2010). The selection and combination of these beliefs employed in this dissertation is appealing as they represent elements that are considered of particular relevance in VW domain. First, attitudinal beliefs are assumed to influence behavior in situations where users can voluntarily use a system and for multiple purposes (e.g., social, hedonic, and utilitarian), which directly applies to VW settings (Jung & Kang 2010; Verhagen, Feldberg, van den Hooff, Meents & Merikivi 2012). Second, the relevance of a study into normative beliefs is highlighted by the fact that VWs are typical social online environments, in which users are constantly observed by and confronted with a changeable cast of other people (Chaturvedi et al. 2011, 675). This social nature makes it plausible to assume that normative beliefs play a critical role in VW user behavior (Merikivi & Mäntymäki 2009). Finally, developing an insight into the influence of control beliefs is of great interest, as VWs often feature simultaneous events requiring users to learn new skills to use the avatar-centric interface to interact with and navigate through the system (Verhagen, Feldberg, van den Hooff, Meents & Merikivi 2011).

1.2 Aim of the study and research question

The general aim of this dissertation is to develop a theoretical framework to examine the indirect and direct effects of key attitudinal, normative and control beliefs on VW continual use intention. This goal translates into the following key research question:

“Why do people continue using VWs?”

Our dissertation intends to offer four principal improvements on two research areas: continual IS use behavior and VW literature. We will accomplish this by using an empirical analysis of data gathered from the largest VW for

teenagers, Habbo Hotel. Our first suggested improvement provides new insights into domain-sensitive attitudinal, normative, and control beliefs underlying continual VW use. The second, delving into the theoretical aspects of the dissertation, offers a detailed understanding of the applicability of DTPB by proposing and testing both indirect and direct influences of the underlying beliefs on continual-use intentions. This can be viewed as a contextual extension (see Berthon, Pitt, Ewing & Carr 2002) and should demonstrate not only the robustness of DTPB as an overarching framework, but also provide indications of the characteristics of continual use and the predictive value of the different theoretical perspectives integrated in this theory. Since DTPB has not yet undergone any empirical scrutiny in the VW domain, our findings should be of great interest to the IS research community in its broadest sense. The third will also expand on the fact that we distinctly make use of actual user data to estimate and validate our model. As most prior research on VWs has made use of student sampling, using real users adds to the external validity of our knowledge of the beliefs underlying continual VW use. Our last suggested improvement involves how the gained insights on the relative influence of the examined beliefs aim to equip operators, designers, and developers of VWs to further align the functionality of VWs, which will better accommodate the expectations of their users. It also adds to the society's knowledge of why young people are continually using VWs.

The research gap, improvements, and contribution areas are illustrated in Figure 1.

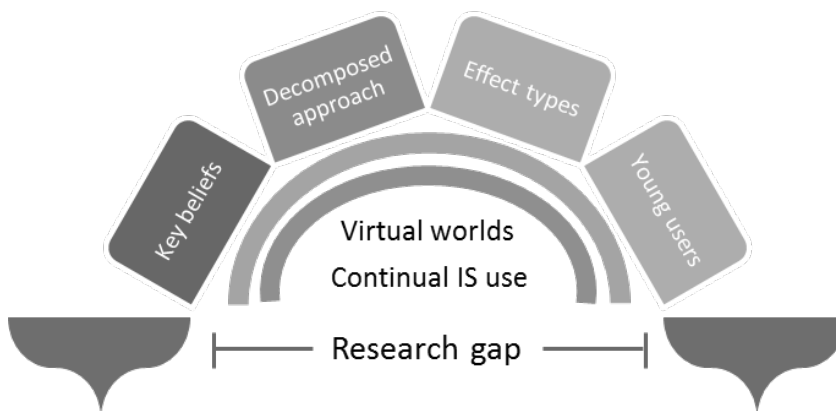

Figure 1 Research gap, improvements and contribution areas

1.3 Research set up and organization

The research process began in 2008 by gaining a preliminary understanding on VW domain (see the timeline in Figure 2). This included a literature review for identifying a base set of constructs that contributed to explaining continual VW use intention. Next, we posed the initial research questions and delineated the appropriate theories that guided us in deriving the initial hypotheses. As a consequence, we put together a conceptual research model employing hypothetical-deductive reasoning of the positivist paradigm. The first research article was published in 2009.

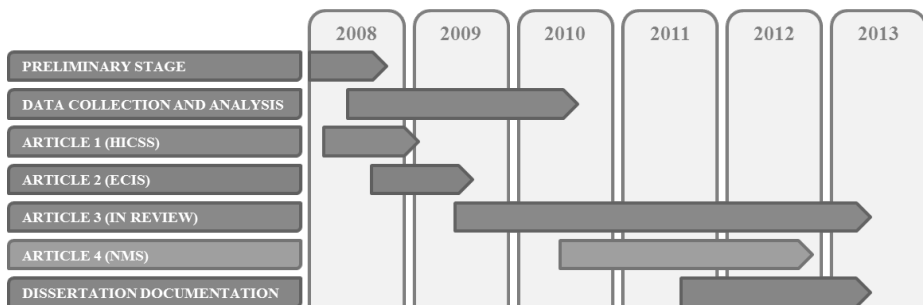

Figure 2 Research timeline

The empirical data ($n=3,265$) was collected from real users of one of the largest VWs, Habbo Hotel, in July 2008. This causes the scope of our study to be delimited to a single VW, which, here, is socially oriented (Zhou et al. 2012). However, while there are differences in system characteristics (Jung 2011; Mäntymäki & Salo 2011), VWs are similar in that they are experienced as a social space (Biocca 2000; Mennecke et al. 2008). From this perspective, we believe our data applies to VW domain, and hence, the term VW is used throughout the dissertation.

To gather the data we adopted the opinion research design which concerns gathering information on attitudes, perceptions and beliefs of human subjects (Jenkins 1985). The design (Figure 3) was realized through non-randomized online questionnaire (after the pilot test) and analyzed using structural equation modeling (SEM). In line with the opinion research design (Jenkins 1985), the preliminary research model was empirically tested and further refined. The results were published in our second research article (June 2009). We then began writing the third article at the end of August 2009. The last of the articles was written between 2009 and 2013. Of these, the fourth one was ac-

cepted for publication in October 2012, and the third article is currently under review.

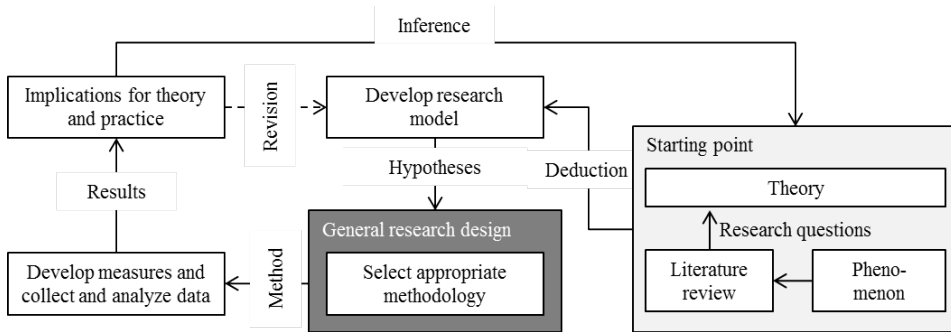

Figure 3 Research design

The findings of these four articles have been analyzed and used as the basis for this dissertation, which is structured in two main sections (see Table 1). The first section is an overall introduction to the dissertation, which precedes the original articles that now form the latter half.

The beginning of the first part seeks to provide a concise background investigation and demonstrate the need for an in-depth understanding of the attitudinal, normative, and control beliefs underlying continual VW use intention. The research objective is then worded into research questions that our dissertation attempts to answer. Besides considering the nomological framework and the constructs on which the original articles are grounded, the first part describes the methodology and tools adopted for this dissertation. Thereafter, it strives to knit the findings of the original research articles closely together and discuss the implications, limitations, and promising future research avenues for the overall topic. Finally, a conclusion to briefly explain the significance of the original articles to the dissertation is provided.

The second part completes the dissertation with four original research articles, two of which were presented in the leading international IS conferences and two of which are published or under review in the communication and IS journals of high quality. The theoretical relationship between the original articles is portrayed in Figure 4.

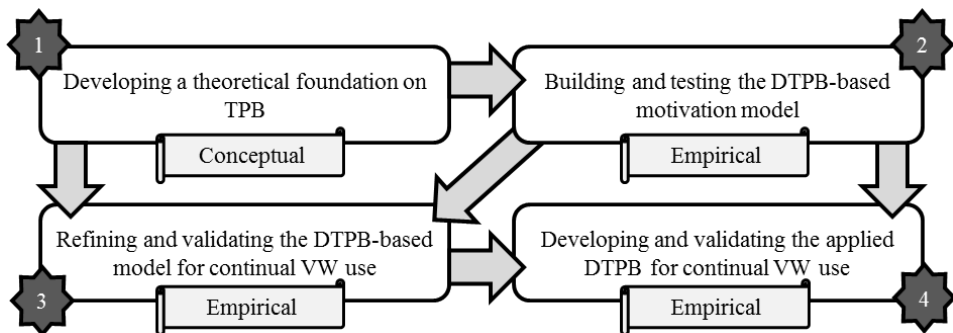

Figure 4 Association between the original research articles

The first article ("Explaining the Continuous Use of Social Virtual Worlds: An Applied Theory of Planned Behavior Approach": Merikivi & Mäntymäki 2009), which is conceptual in its scope, was presented at the 42nd Hawaii International Conference on System Sciences in Waikoloa, Hawaii, in January 2009. It pays particular attention in choosing and developing an appropriate nomological framework for exploring continual VW use through IS discipline, an approach assumed to make the best contribution to the IS adoption research community (Benbasat & Zmud 2003). By proposing a research model based on the applied TPB, the article attempts to expand our portfolio of the overall goal of this dissertation. The article-specific research question is as follows: "What are the beliefs that influence continual VW use intention?"

The second article ("What Habbo Goers Do in Practice? Decomposing Attitudinal Beliefs": Merikivi 2009) was presented at the 17th European Conference on Information Systems in Verona, Italy, in June 2009. It continues from where the first article ends by paying particular attention to attitudinal beliefs. That is, the perspective the article holds attempts to clarify the motives behind continual VW use. In what follows, we adopted DTPB as our theoretical foundation and applied motivation theory (Ryan & Deci 2002) to shed more light on the beliefs (i.e., motives) determining attitude towards VW use. The objective translates into the following article-specific research question: "What motivates people to continual VW use?" The proposed research model is tested

and validated with 1,225⁴ responses of active Habbo Hotel users. The analysis is performed using AMOS software.

The third article (Mäntymäki, Merikivi, Verhagen, Feldberg & Rajala, in review), “Still there? Understanding the continued use of virtual worlds”, is an unpublished article which is currently under review. It supplements the extant theoretical and managerial discussions by adding novel insights into how VW users can be best retained and how operators can respond to their expectations. Broadening the conceptual grounds and empirical findings from the previous research articles, it embodies three auxiliary theories (i.e., self-determination theory (SDT: Ryan & Deci 2000b), innovation diffusion theory (IDT: Rogers 2003), and social cognitive theory (SCT: Bandura 1999)). To put more value to its findings it provides a concise context-centric review to better suit the proposed research model into a VW setting. As such, the article introduces a more complete research perspective and aims at delivering an in-depth understanding of the attitudinal, normative, and control beliefs underlying continual VW use intention. To meet this goal, the article-specific research question is formulated as follows: “To what extent do attitudinal, normative, and control beliefs influence continual VW use intention?” The proposed research model is tested and validated on survey responses from 921 Habbo Hotel users. The analysis software adopted is AMOS.

The last of the articles (“Having belief(s) in social virtual worlds: A decomposed approach”: Merikivi, Verhagen & Feldberg 2012) was accepted for publication in *New Media and Society* in November 2012. While aiming at contributing to previous research articles and the existing knowledge base, it proposes and tests a model grounded on the applied DTPB. The article exemplifies the VW sensitive attitudinal, normative, and control beliefs as direct antecedents to continual VW use intention. The general TPB constructs, which serve as a mediator between the introduced beliefs and continual VW use intention, have been removed. Such a modification of the decision-making process not only separates the article from the previous articles but also helps elucidate the decision-making process itself. Concomitantly, the article-specific research question is as follows: “To what extent do attitudinal, normative, and

⁴ Note that the final sample sizes, which include only complete responses, differ across the articles. This is due to varying inclusion of criteria and variables.

control beliefs directly influence continual use intention?” Using PLS software, the research model is tested with 2,175 users inhabiting Habbo Hotel.

Table 1 Organization of the study

Part 1	Part 2			
Dissertation overview	<i>Article 1</i> (HICSS2009)	<i>Article 2</i> (ECIS2009)	<i>Article 3</i> (in review)	<i>Article 4</i> (NMS2012)
Introduction	Sheds light on the nature of VWs and proposes an applicable theory that explains continual VW use Article-specific RQ: “What are the beliefs that influence continual VW use intention?”	Proposes and tests a model for investigating attitudinal beliefs Article-specific RQ: “What motivates people to continual VW use?”	Adds new insights into how users can be retained and how operators may respond to users’ variegated expectations Article-specific RQ: “How, and to what extent, do attitudinal, normative, and control beliefs influence continual VW use intention?”	Tests and validates the direct effects of VW-sensitive attitudinal, normative, and control beliefs on continual VW use Article-specific RQ: “How, and to what extent, do attitudinal, normative, and control beliefs <i>directly</i> influence continual VW use intention?”
Theoretical background	Applies the theory of planned behavior	Expands on DTPB	Refines DTPB by embodying three auxiliary theories (SDT, IDT, SCT)	Applies the VW-centric DTPB
Methodology	Utilize the positivist paradigm and explanatory research strategy			
	Conceptual	Embrace opinion research design; build on cross-sectional quantitative online questionnaire conducted in 2008 using a convenience sample of real VW users; apply structural equation modeling (SEM); and comply with the guidelines set by the national advisory board on research ethics		
			AMOS	PLS
Research contribution	Develops a decomposed model and identifies key constructs for continual VW use	Highlights the relative importance of intrinsic motives as a driver of attitude	Supports the use of the TPB components and corroborates intrinsic motive, interpersonal influence, and self-efficacy as key drivers in continual VW use intention	Indicates a strong direct influence of attitudinal beliefs, and the irrelevance of normative beliefs on continual VW use intention
Discussion	Suggests continual VW use is determined by attitude, subjective norm, and perceived behavioral control	Supports the disaggregation of belief sets behind continual VW use	Demonstrates the need for a theory-based disaggregation of determinants influencing continual VW use	Reasons the use of a more direct approach to explain continual VW use
Summary	The provision of an enjoyable and comfortable user experience – perceived either spontaneously or through conscious evaluation – and that it is supported by the positive opinions of friends and other referents, is likely to make users continue using VWs.			

2 THEORETICAL BACKGROUND

This section begins by elaborating on the distinctive attributes of VWs, followed by a proposition to set up the theoretical selection, which draws on the relevant strands of thought in prior IS adoption research. It will then, provide knowledge on how we adapt the theory to decompose the appropriate constructs into domain-sensitive beliefs leading to continual VW use. Finally, an overall model viewing the adopted constructs and their relationships is presented.

2.1 Virtual world attributes

In terms of system use, there are three attributes in which VWs differ from other online systems: functionality, sociability, and immersive usability.

VWs offer a multitude of different functions available to each user. VWs allow their users to engage in multiple activities (Verhagen et al. 2012) by integrating games, socialization, education, and business (e.g., Castronova 2006; Tikkanen, Hietanen, Henttonen & Rokka 2009). Such a multifaceted user experience efficiently blurs the boundaries between work and play, a premise frequently employed to separate hedonic and utilitarian information systems (Nevo, Nevo & Kim 2012). Hence, VWs are here portrayed side by side with an emerging class of information technology, referred to as multi-purpose information systems (MPIS), which provide social, hedonic, and utilitarian benefits (Gu, Fan, Suh & Lee 2010; Hong & Tam 2006).

VWs make meaningful social environments (Goel et al. 2011; Goel, Johnson, Junglas & Ives 2013). While sociability in VWs has much in common with instant messaging and virtual communities, they also offer an exclusive means to interact with other inhabitants. At any given time, there are large numbers of other VW users with whom to interact via text, audio, video, and tactual inputs (Goel et al. 2013). In essence, these inputs enable users to sense others as being psychologically present (e.g., Biocca, Harms & Burgoon 2003; Seegert 2009; Yoo & Alavi 2001), thus making sociability more tangible in VWs than in other online systems, such as discussion forums or real-time chat rooms.

Within the VVs, users are represented as avatars not normally present in the use of traditional online systems (e.g., websites). Given that these avatars are modifiable and interact in highly dynamic environments that cannot be paused or controlled at will but still continue to “exist and function” (Bell 2008, 4), VVs indeed greatly enhance the immersive usability of the system. Consequently, navigating by means of avatars provides users with a strong sense of “being there” (e.g., Kohler et al. 2011; Lombard & Ditton 1997), making VVs seem as if they were self-contained locations within the boundaries of which all interaction occurs (Goel et al. 2011).

While functionality, sociability, and immersive usability are not inherent to VVs alone, VVs stand out in that these attributes together make up the user experience. Therefore, these attributes do not distinguish one type of VV from others but exclude other online systems, such as discussion forums and video games from VV domain. The approach adopts Hunt’s (1991) classification procedure to form categories. This implies that the aforementioned attributes can be applied when describing VVs regardless of its type. For example, game-oriented VVs (e.g., World of Warcraft), an opposite to socially oriented VVs (e.g., Second Life), contain a specific pre-determined narrative goal but can and are often used for other purposes such as business (Heeks 2010; Lehdonvirta 2009).

Taking the above into account leads us next to search for an adaptable theoretical foundation. To this end, we follow Benbasat and Zmud (2003) in that the attributes intimate and specific to each IS are essential in explaining user behavior and advance the theory which embodies the three distinctive attributes of VVs.

2.2 Decomposed theory of planned behavior

To integrate functionality, sociability, and immersive usability into continual IS use research, we expand on the decomposed theory of planned behavior (DTPB: Taylor & Todd 1995a).

In essence, DTPB is a derivative of TPB (Ajzen 1991), which maintains that the proximal determinant of an individual’s behavior is behavioral intention, which, in turn, is a function of attitude, subjective norm, and perceived behavioral control (Figure 5.) Attitude stands for an individual’s overall positive or negative feelings towards a behavior (Fishbein & Ajzen 1975), whereas subjective norm addresses the perceived social pressures put on an individual to perform or not perform the behavior in question (Ajzen & Fishbein 1980). Lastly, perceived behavioral control concerns the perceived ease or difficulty

of performing the behavior of interest (Ajzen 1991). As a general rule, “people intend to perform a behavior when they evaluate it positively, when they experience social pressure to perform it, and when they believe that they have the means and opportunities to do so.” (Ajzen 2005, 118)

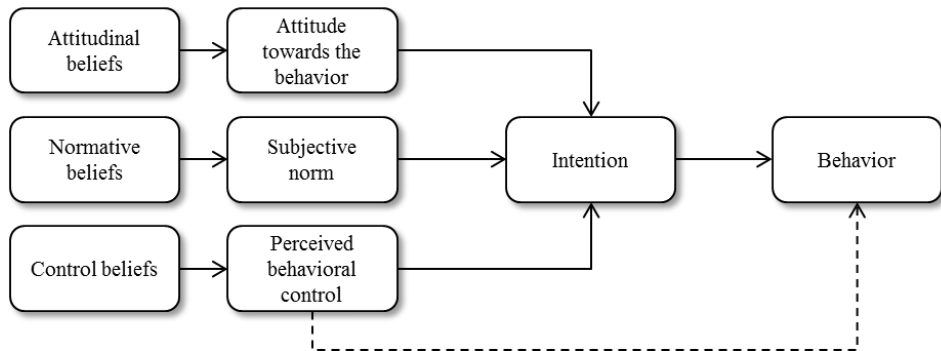

Figure 5 Theory of planned behavior

The theoretical justification of intention-behavior relation postulated by TPB is derived from cognitive dissonance theory (Festinger 1957), which holds that individuals attempt to behave in accordance with their intentions. Despite being criticized for this relationship (Limayem, Hirt & Cheung 2007; Ouellette & Wood 1998), TPB has been successfully applied to numerous behavioral settings, including system use, and the overall evidence support its predictive and nomological value (Ajzen 2002a; De Cannière, De Pelsmacker & Geuens 2009; Sheppard, Hartwick & Warshaw 1988) – even in the post-adoption settings, where users have already gained experience using the system (Szajna 1996).

DTPB follows TPB in that it considers that “new information may lead to the formation of new beliefs or alter previously formed beliefs.” (Doll & Ajzen 1992, 756) That is, both experience and new information are taken into account in influencing future decision-making (cf. Bhattacharjee 2001). Further, as continual VW use is influenced by the multitude of in-world activities and presence of constantly changing co-users it is likely that these interven-

tions (which produce new information) change the way that users treat and think about VWs, demanding users to enter into intentional relationships with the system (Jasperson, Carter & Zmud 2005; Verhagen, Feldberg, van den Fooff & Meents 2009). Presumably, while past use increases, VW domain remains overly unstable⁵ for users to rely simply on habit, which refers to linking situational context and subsequent actions automatically (Kim & Malhotra 2005). Hence, continual use intention is expected to be an immediate and strong predictor of actual future behaviors within VW domain.

Another seemingly controversial and difficult issue concerns the importance of the mediating role of the TPB constructs (i.e., attitude, subjective norm, and perceived behavioral control). In their broadest sense, where beliefs deal with an individual's understanding of themselves and their environment (Fishbein & Ajzen 1975), the TPB constructs facilitate their adaptation to the environment (Eagly & Chaiken 1998). Without them, "our environment would make little sense to us; the world would be cacophony of meaningless blessings and curses." (Fazio & Olson 2003 139) Or, as Wilson, Lindsey and Schooler (2000, 101) put it: "It is difficult to imagine a person who is impartial toward all that he or she encounters." Breaking the world into likes and dislikes delivers order and predictability (Katz 1960), as well as provides guidance to achieving one's personal goals or objectives (Demski & McGlynn 1999; Snyder & DeBono 1989). It is thus plausible to believe that, as specified in TPB, beliefs would hold explanatory value only if they account for their respective TPB constructs (Fishbein 1979).

However, in technology acceptance model (TAM: Davis 1989) and its extension, the unified theory of acceptance and use of technology (UTAUT: Venkatesh 2003), for example, attitude and subjective norm, have been discounted. Attitude was omitted as it did not fully capture the impact of the selected (instrumental) beliefs (Davis, Bagozzi & Warshaw 1989). Subjective norm was excluded because "it was difficult to disentangle direct effects of SN [subjective norm] on BI [behavioral intention] from indirect effects of A [attitude]." (Davis et al. 1989, 986) The relevance of perceived behavioral control, in turn, has been questioned by Godin, Gagné and Sheera (2004). Even

⁵ A stable context is necessary for habitual behavior to occur (Aarts, Verplanken & Van Knippenberg, 1998; Ajzen, 2002b).

Ajzen and Fishbein (1980) have reported that beliefs may directly be related to behavioral intention as long as they predict their respective TPB constructs, and the TPB constructs are significant predictors of behavioral intention. Since both indirect and direct approaches are supported by strong theoretical (Bagozzi 1982; Triandis 1977; 1979) and empirical evidence in the IS field (Davis et al. 1989; Taylor & Todd 1995b) and also in VW domain (Mäntymäki & Salo 2011; Schwarz et al. 2012), we follow the steps taken by Premkumar, Ramamurthy, and Liu (2008) and relate the underlying beliefs to continual use intention over and above attitude, subjective norm, and perceived behavioral control. Such a less unconstrained approach is further advocated by Stutzman and Green (1982) who noted that the rigid relationships are more appropriate for simple behaviors, analogous to a single act criterion.

To further cement our theoretical choice, we will now turn our attention to belief structures. In particular, Taylor and Todd (1995a;b), based on Shimp and Kavas (1984), highlighted the need for disaggregation of the beliefs underlying attitude, subjective norm, and perceived behavioral control to arrive at a fuller understanding of why people hold certain beliefs over an adoption behavior. In TPB, attitude towards a behavior is determined by attitudinal beliefs, and concerns an individual's behavioral feelings towards using a system. Subjective norm is a function of normative beliefs, that is, an individual's perceptions about using a system in relation to the opinion and impact of others. Lastly, perceived behavioral control is regulated by control beliefs that deal with an individual's perceptions about the control they have while using a system (control beliefs) (cf. Fishbein & Ajzen 2010). To directly apply these belief types into the specific context of the research setting, Taylor and Todd (1995a;b) recommended decomposing them into more comprehensive sets of beliefs (Figure 6).

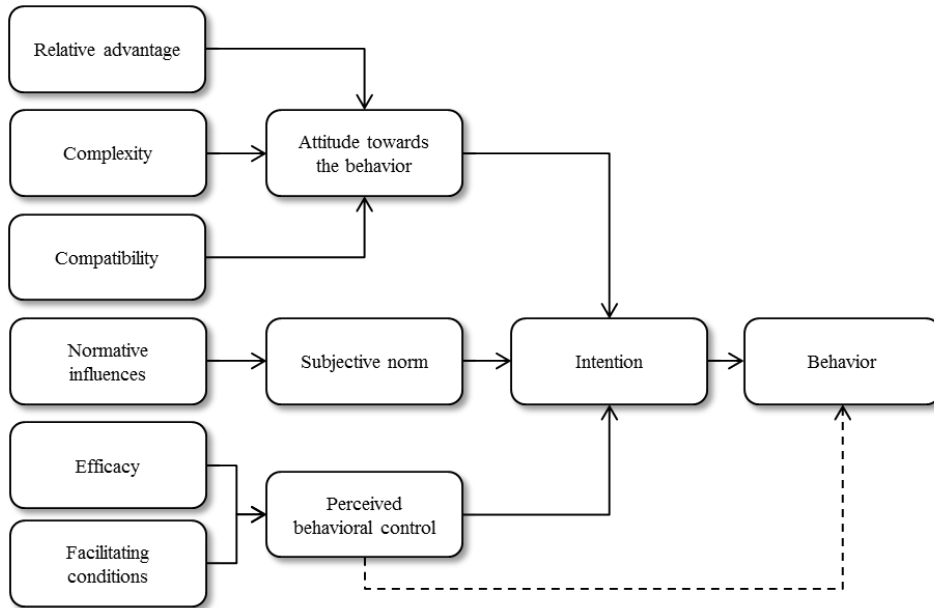

Figure 6 The original DTPB

To do this, Taylor and Todd (1995a;b) integrated the TPB components with beliefs drawn from other technology adoption models, such as TAM (Davis 1989) and IDT (Rogers 2003). From this perspective, the terms attitudinal beliefs, normative beliefs, and control beliefs are used, each of them referring to the particular conceptualization they are decomposed from. In comparison to other more parsimonious models, such as theory of reasoned action (TRA: Fishbein & Ajzen 1975), the strength of DTPB lies in its structural flexibility and richness (Benbasat & Barki 2007; Pavlou & Fygenson 2006), and yet its underlying theoretical premise serves for investigating continual IS use. (See Appendix 1 for an overview of IS adoption theories and models.⁶) This allows for newness and a deeper reconstruction of reality, which are required in gaining understanding for specific technological innovations such as VWs (Christopher, John & Vandenbosch 2001).

⁶ For a more detailed list of theories used in IS adoption research, visit <http://aadref.googlepages.com> (Williams, Dwivedi, Banita & Schwarz, 2009).

In sum, the foundation of our approach draws on DTPB and is formed by continual VW use intention, which in turn is determined by attitudinal, normative, and control beliefs over and above attitude, subjective norm, and perceived behavioral control.

2.3 Adapting DTPB to VW domain

To furnish the theoretical rationale mentioned above and to select the relevant attitudinal, normative, and control beliefs manifesting the key VW attributes, we performed a literature review that builds on and updates our existing review of previous empirical studies on our topic (Merikivi et al. 2012). To touch the key contribution already available (Webster & Watson 2002) we scanned the Senior Scholar's Basket of Journals by the Association for Information Systems.⁷ Very little was achieved. We then continued our review by using five scientific databases⁸ that draw on disciplines such as information systems, computer science, marketing and social psychology. The following search terms were used: "virtual world", "online game" and "online world" (abstract, title, or key words). The cursory examination showed that many of the search results were beyond our focus. Therefore, we decided to narrow our search down to VW studies on adoption behavior research. This resulted in an initial pool of about 100 potential studies that were retrieved and skimmed for assessment. Given our topic, we put a priority on studies that examined continual use. The assessment led to a collection of 17 studies, which were included in our final review. They are summarized in Table 2.

⁷ <http://home.aisnet.org/displaycommon.cfm?an=1&subarticlenbr=346> (retrieved Oct 17 2012).

⁸ ABI/INFORM, Business Source Complete, PsycINFO, ScienceDirect and Wiley.

Table 2 Empirical post-adoption studies on VWs

Author(s)	Focus	Theoretical framework	Constructs studied	Sample	Key findings
Choi and Kim (2004)	Examines the customer loyalty of online games	Exploratory approach	Customer loyalty, flow, optimal experience, personal and social interaction	1,993 respondents using various online games	Optimal experience determined by personal and social interaction fosters customer loyalty
Lu and Wang (2008)	Explores the extent to which addiction and satisfaction influence loyalty towards online games	Exploratory approach	Control beliefs, normative beliefs, perceived playfulness	1,186 players using various online games	Satisfaction contributes to loyalty more than addiction
Yang et al. (2009)	Assess the factors antecedent satisfaction and loyalty towards online games	TAM	Experiential value, transaction cost, service quality	877 players using various online games	Service quality and transaction cost support loyalty indirectly
Lee and Tsai (2010)	Examines why people continue to play online games	TAM; TPB	Flow, perceived ease of use, perceived enjoyment	415 online game players	Attitude, subjective norm, behavioral control flow, and enjoyment influence continual use intention
Teng (2010)	Investigates how customization, immersion satisfaction, and gamer loyalty are related within online games	Reinforcement theory	Customization and immersion satisfaction	865 players using various online games	Customization and immersion satisfaction promote loyalty
Barnes (2011)	Examines the reasons why people continue using VWs	Instant activation perspective; habit/automaticity perspective	Perceived usefulness, enjoyment, habit	339 users of Second Life	Continual use is driven by perceived usefulness, enjoyment, habit, and instant activation
Goel et al. (2011)	Investigates factors that predict continual VW use	Interactionist theory of place attachment	Cognitive absorption	199 students using Second Life	Continual use is determined by a state of deep involvement
Huang and Hsieh (2011)	Explores the factors affecting consumer loyalty towards online games	Uses and gratifications theory; theory of flow	Entertainment, sociality, challenge, control, interactivity	126 interviews and 126 questionnaires of players using various online games	Players' sense of control, perceived entertainment, and challenge affect loyalty

Author(s)	Focus	Theoretical framework	Constructs studied	Sample	Key findings
Jung (2011)	Identifies the factors that influence continual VW use	Expectation disconfirmation theory (ECT)	Telepresence, social presence, and perceived autonomy	194 users of Second Life	Continual use is determined by the sense of presence and perceived autonomy
Mäntymäki and Salo (2011)	Examines the drivers that influence continual VW use	TAM	Enjoyment, perceived aggregate network exposure, perceived usefulness, perceived ease of use	2,481 users of Habbo Hotel	Perceived enjoyment and usefulness affects continual use
Hsiao and Chiou (2012a)	Explores how network centrality influence continuance intention	Social capital theory	Perceived network centrality, non-guild interaction, perceived enjoyment, access to resources	347 players of World of Warcraft	Access to resources lead to game continuance
Hsiao and Chiou (2012b)	Examines how user position influences continual MMOG use	Social capital theory	Community position, community trust and social value	347 players of various MMOGs	Community position has an indirect effect on continual intention via community trust and social value
Nevo et al. (2012)	Explores the cross-contextual use of VWs	Exploratory approach	Recreational, work usage, and cognitive absorption	203 professionals involved in VWs	Through cognitive absorption, recreational usage promotes work usage intentions
Schwarz et al. (2012)	Explains VW assimilation	TRA	Ease of use, playfulness, social presence, self-distraction	223 users of Second Life	Technology and community class of factors influence intention via attitude towards VWs
Teng et al. (2012)	Investigates relationships among gaming challenge, interdependence and gamer loyalty within online games	Interdependence theory; bilateral deterrence theory	Challenge, interdependence, loyalty	994 players using various online games	Gaming challenge influences gamer loyalty directly and via interdependence
Zhou et al. (2012)	Explores continual SVW use	Dedication-constraint framework of commitment	Satisfaction, affective commitment, calculative commitment	438 experienced users of Second Life	Continuance is influenced by affective and calculative commitment
Goel et al. (2013)	Examines retention from social perspective	Spatial model of interaction; awareness-attention theory	Focused immersion, temporal dissociation, social perception, social awareness	175 students testing Second Life in a laboratory study	Intention to return is explained by focused immersion and temporal dissociation

MMOG: Massive multiplayer online game

Our review unveils four important points. First, despite the considerably large number of available publications on VWs, relatively little research exists on post-adoption behavior in VWs (see also Jung 2011). Of those, only Mäntymäki and Salo (2011) studied adolescents, the largest user group of VWs (kZero 2011). Second, the review reveals that the focus is rarely placed on examining both the indirect and direct effects of the underlying beliefs on continual VW use. Third, while the available studies have adopted a multitude of diverging theoretical perspectives (e.g., ECT: Jung 2011; TAM: Mäntymäki 2011; TRA: Schwarz et al. 2012), DTPB has not yet been included in the empirical discourse. The resulting theoretical silence suggests that the decomposition of the attitudinal, normative, and control beliefs, and the order of their relative importance have largely remained unaddressed (e.g., Goel et al. 2011; Schwarz et al. 2012). Fourth, while our decomposed approach responds to this need, it fails to identify which attitudinal, normative, and control beliefs should be associated with continual VW use intention. Unfortunately, the studies reviewed here are abundant only in mapping attitudinal beliefs (see e.g., Huang & Hsieh 2011). To normative and control beliefs, they seem to pay only partial attention. To complete our approach and to make all these belief types adaptable to VW domain, we follow Taylor and Todd (1995a;b) and integrate the decomposed approach with three auxiliary theories: self-determination theory (SDT: Deci & Ryan 2000), diffusion theory (IDT: Rogers 2003), and social cognitive theory (SCT: Bandura 1986).

SDT deals with human motivation. It holds that people vary in motivational orientation, that is, “the underlying attitudes and goals that give rise to action.” (Ryan & Deci 2000a, 54) Based on these attitudes and goals, motivational orientations fall into two general motivation types, intrinsic and extrinsic motives. Intrinsic motive exemplifies self-determined behavior, implying that an intrinsically motivated individual engages in an activity freely and because they find it interesting, thus deriving “spontaneous satisfaction from the activity itself” (Gagné & Deci 2005, 331). Extrinsic motive, in turn, is controlled and does not stem from inherent interest. Hence, an extrinsically motivated individual is driven by external sanctions, pressures, or rewards (Ryan & Deci 2000a;b). Given the above, and the fact that both these motivation types are intentional (Gagné & Deci 2005), SDT is used here to tap into the various attitudes central in VW domain (Jung & Kang 2010; Verhagen et al. 2012) and validate the different motivation types concerning continual VW use intention.

IDT, in turn, is favored as it incorporates useful social influences directing VW users’ behavioral intentions. It is a widely accepted and particularly convenient theory for examining the social conditions which influence IS adoption and use (e.g., Cheung, Chan & Limayem 2005; Cooper & Zmud 1990;

Moore & Benbasat 1991). The theory maintains that the diffusion is a process during which information about the innovation flows through communication channels among members of a social system (Rogers 2003). Further, IDT argues that the nature of these channels and the volume the members play in them influence the opinion and judgment of the decision maker – a premise considered relevant for our research objective. For these reasons, we adopt IDT and elaborate on communication channels and their volume types to identify and decompose normative beliefs.

Finally, SCT is selected for its applicability to investigate controllability (e.g., the use of the avatar-centric interface to interact with and navigate through the system (Verhagen et al. 2011)). Generally, the theory posits that human behavior results from interplay among behavioral, personal (cognition, affect, and biological events), and environmental factors (Bandura 1986). From the controllability perspective, SCT implies that the beliefs people have about themselves and about the environment are pivotal in deciding whether to engage in a behavior. To clarify the process further, SCT proposes that people are both producers (competence) and receivers (control) of environmental influence: not only do people consider their own competence but also how easy or difficult the behavior can be. Pointedly, the use of SCT to decompose controllability into competence and control helps us identify the control beliefs salient for continual VW use intention. See Table 3 for a summary of theories.

Table 3 Auxiliary theories

Theory	Overview of the theory	Rationale for decomposition	Reference
Self-determination theory (SDT)	SDT concerns motives and their sources. It makes a distinction between extrinsic and intrinsic motive in terms of self-regulation.	Motivational orientation	Deci and Ryan (2000)
Innovation diffusion theory (IDT)	IDT assumes that individuals discuss innovations using different channels and that the channels possess different degrees of power at various adoption stages in the diffusion process.	Communication channels and influence volume	Rogers (2003)
Social cognitive theory (SCT)	SCT seeks to understand human behavior as an interaction of personal factors, behavior, and the environment.	Competence and control	Bandura (1977; 1986)

2.4 Decomposing attitudinal, normative, and control beliefs

Following SDT, we map attitudinal beliefs to extrinsic and intrinsic motives. The reasoning is in line with prior studies that mirror the multipurpose nature of VWs (e.g., Barnes 2011; Shin 2009; Verhagen et al. 2012). Extrinsic motive propels in achieving valuable goals and outcomes (e.g., reward, recognition), while intrinsic motive refers to other outcomes (e.g., enjoyment and playfulness), resulting from performing the activity (Ryan & Deci 2000a). To reflect both these motivation types, six distinct constructs were captured: perceived enjoyment, playfulness, and connectedness, which tap into intrinsic motive, and perceived usefulness, status, and uniqueness, which concern extrinsic motive.

Perceived enjoyment (Davis, Bagozzi & Warshaw 1992) concerns activities such as exploring and manipulating the appealing environmental attributes of VWs (e.g., virtual decoration and fashion shows). Playfulness (Woszczynski, Roth & Segars 2002) reflects the users' concentration and curiosity relevant to playing in-world games (e.g., role playing and arcade games). These entertaining activities are typical to VWs, which makes the inclusion of perceived enjoyment and playfulness worthwhile. Connectedness (Baumeister & Leary 1995; Deci & Ryan 2000) in turn is established through social interaction, a central activity within online social networks as users spend considerable time maintaining existing friendships or making new ones in a search for companionship, support, and affiliation (Chiu, Hsu & Wang 2006; Rheingold 2000).

Perceived usefulness (Davis 1989; Hong, Thong & Tam 2006) reflect here the communicational benefits (Tan, Tan & Teo 2012), noted by users as they complete tasks such as attending courses, trading digital property, and obtaining useful information from other users (Jung & Kang 2010). In this respect, an examination of perceived usefulness is of particular interest. Social status also has instrumental value, conferred on a user as an implication of social recognition, thereby motivating an individual to continue using a VW (Venkatesh & Brown 2001). The relative position of VW users is closely linked to uniqueness (Ruvio 2008; Tian 2001), which mirrors the need for differentiating oneself from others through avatars and virtual consumption (Suh, Kim & Suh 2011; Vasalou, Joinson, Bänziger, Goldie & Pitt 2008).

To decompose normative beliefs, we draw on innovation diffusion theory (IDT) (Rogers 2003). IDT posits that an individual seeks information regarding the advantages and disadvantages of a technological innovation through mass media and interpersonal channels; the choice depending on the accessibility to these channels and the likelihood that they deliver information relevant for their decision making. The distinction in channels conforms to previ-

ous IS literature, where social influence (Ajzen 1991) is used to refer to interpersonal channel and external influence to mass media (Bhattacharjee 2000; Chiu et al. 2006). Given their coverage in the media (Sulake Corporation 2009), and that interpersonal influence plays a role in shaping behavior in online social networks (Brown, Broderick & Lee 2007), their use is of particular interest from the VW perspective. Furthermore, as indicated by the literature review (see e.g., Lu & Wang 2008; Mäntymäki & Salo 2011), VW users are literally surrounded by masses of others (volume) that add to and benefit from the network externalities of a system (Latané 1981; Matei & Ball-Rokeach 2001). To embody this quantitative appraisal (Rogers 2003), we include perceived critical mass (Lou, Luo & Strong 2000; Valente 1995; van Slyke, Ilie, Lou & Stafford 2007) in our research model. In sum, all three of these normative belief types address prominent pressure associated with using VWs, but have not previously been investigated in such combination.

Finally, the selection of control beliefs complies with SCT, which posits a triadic reciprocal relationship among behavior, personal factors, and the environment. To elucidate the interplay of these three factors demonstrating competence and control, three potential beliefs were detected, based on the literature review: perceived ease of use, self-efficacy, and social presence⁹, which may affect access to the system or its use.

Perceived ease of use refers to the degree to which an individual believes that using a particular system is free of effort (Davis 1989). A study into the role of ease of use is of particular interest (Verhagen et al. 2012) and its alignment as a control belief is supported by Gagné and Godin (2007) as constraints and facilitating conditions are closely associated with skills needed to master avatars to interact with and navigate through the system (Verhagen et al. 2012). This makes it likely that perceived ease of use mirroring an individual's capacity to handle the complexity of the system interface influence behavior in VW domain. Self-efficacy (Bandura 1977; 1982) considers the do-

⁹ Although modeled initially as an attitudinal belief (1st article), social presence is considered here (and in 3rd article) as a control belief. The decision is based on the theorizing of Daft and Lengel (1984) and the results of the first article (Merikivi, 2009), which found that the effect of social presence on attitude was marginal.

main-sensitive perspective (cf. Agarwal, Sambamurthy & Ralph 2000; Hsu & Chiu 2004), and as such focuses on the use of avatars to navigate within a system and interact with other users. The social side is included due to the fact that an individual's self-confidence is influenced by the confrontation and unpredictable actions of other users. The system *persistently* evolves due to the actions taken by other users, which may affect a user's ability to master one's performance (Animesh, Pinsonneault, Sung-Byung Yang & Oh 2011; Ijsselstein 2005). The last control belief is social presence (Biocca et al. 2003; Short 1976). Conceptually, the construct follows the media richness theory (Daft & Lengel 1984), which posits that a media capable of transmitting immediacy maintains effective communication in equivocal situations. Given the equivocality of VWs (Chaturvedi et al. 2011; Chesney, Coyne, Logan & Madden 2009), the social presence adds to the understanding of the domain, especially through the embodiment of avatars, which provides users with a sense of immersion and interactivity. Accordingly, VWs capable of irradiating human contact and warmth are likely to lower barriers to ask for advice or assistance from other users, thereby promoting system controllability and sustained use. The effect is expected to grow when users discover more avenues for help and support, as it also reduces undesirable behavior such as cyber bullying or virtual fraud that would impede VW use (Chesney et al. 2009).

The overall DTPB-based model viewing the constructs and their relations are shown in Figure 7, and the constructs embodied as beliefs examined in this dissertation are summarized in Table 4.

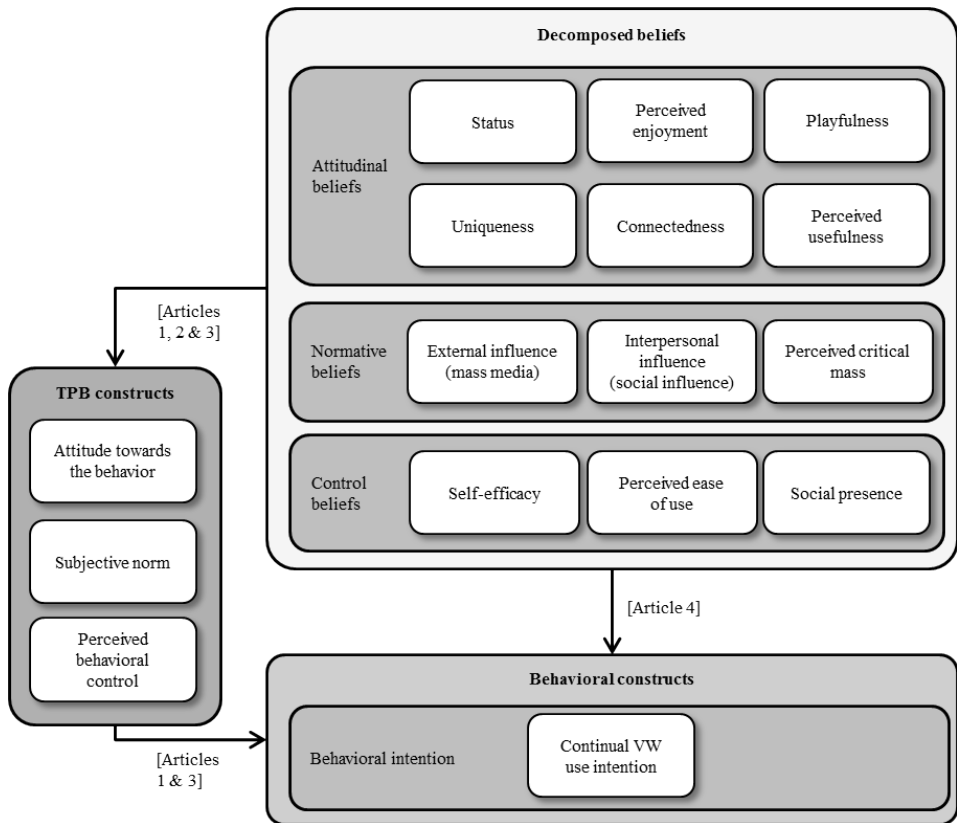

Figure 7 The overall DTPB-based model viewing the adopted constructs and their relations

Table 4 Summary of the adopted constructs

Construct ¹	Definition	Theoretical grounding	Key references
Continual VW use intention	Behavioral intention to participate and continue using a VW	TRA, TPB	Ajzen (1991); Goel et al. (2011); Hsieh et al. (2008)
Attitude	An individual's general feelings of being favorable or unfavorable towards use of a VW		Ajzen (1991); Fishbein and Ajzen (1975)
Subjective norm	The degree to which an individual perceives social pressure to use a VW		
Perceived behavioral control	The degree to which an individual perceives constraints on using a VW	TPB	
Connectedness	The degree to which the use of a VW provides a sense of connectedness to others in his or her social system	SDT	Deci and Ryan (2000); Lee and Robbins (1995; 1998)
Playfulness	The degree to which an individual perceives that a VW provides short-term entertainment		Woszczynski et al. (2002)
Perceived enjoyment	The degree to which the use of a VW is perceived enjoyable in its own right	SDT, TAM	Davis et al. (1992); Ryan and Deci (2000a)
Perceived usefulness	The degree to which the use of a VW is perceived to provide certain benefits when performing certain tasks		Davis (1989); Davis et al. (1989); Ryan and Deci (2000a)
Uniqueness	The degree to which the use of a VW caters to the need for uniqueness	Need for uniqueness theory	Ruvio (2008); Snyder and Fromkin (1977)
Status	The degree to which the use of a VW is perceived to enhance an individual's status in his or her social system	SDT	Moore and Benbasat (1991); Ryan and Deci (2000a); Venkatesh and Brown (2001)
External influence (mass media)	The degree to which mass media, commercials, and experts influence an individual's decision to use a VW	IDT	Bhattacharjee (2000); Rogers (2003)
Interpersonal influence (social influence)	The degree to which an individual perceives that important others believe they should use a VW	TRA, TPB	Ajzen (1991); Bhattacharjee (2000)
Perceived critical mass	The degree to which an individual perceives most of the members in their network are using a VW	Network externality theory	Lou et al. (2000); Rogers (2003); van Slyke et al. (2007); Valente (1995)
Perceived ease of use	The degree to which an individual perceives use of a VW is free of effort	TAM	Davis (1989); Davis et al. (1989)
Self-efficacy	The degree of self-confidence an individual has about their capability to use a VW	SCT	Agarwal et al. (2000); Bandura (1977; 1986)
Social presence	The degree to which the use of a VW promotes human awareness in a communication interaction	Social presence theory	Jung (2011); Biocca et al. (2003); Short (1976)

¹ Only constructs that have been subjected to empirical analysis in our dissertation are listed. In case the construct names vary across the articles included in this dissertation, analogues are indicated in parentheses after each construct name.

3 METHOD AND RESULTS

This section presents a detailed account and description of philosophical and methodological assumptions underlying this dissertation. It begins with ontological and epistemological underpinnings and then moves on to methodological issues. The section ends with highlighting the key results of the research articles.

3.1 Positivist paradigm

According to Iivari, Hirschheim, and Klein (1998), each epistemology (“speaking of knowledge”) presumes a corresponding ontological doctrine (i.e., “speaking of being”), which, in the positivist tradition, is synonymous to seeing reality as being “out there” and independent of the observer’s appreciation (Burrell & Morgan 1979; Goles & Hirschheim 2000, 252; Orlikowski & Robey 1991). While the positivist paradigm has been strongly criticized for its ontological premise as disregarding the contextual conditions leading to insufficient understanding of the phenomenon at the expense of generalization (Orlikowski & Baroudi 1991), we decided to follow the positivism over interpretivism (i.e., reality is subjectively determined: Walsham 1995). This is because our primary goal here is to test the applicability of our research models, which then puts generalization over contextualization. Critical realism (Mingers 2001; Orlikowski & Baroudi 1991), which advocates ontological pluralism, is excluded on the basis of *tertium non datur* (“no third is given”) – reality can either be viewed as objective or subjective (Stahl 2008).

Given (logical) positivists reject metaphysical deliberation at its face value as empirically non-verifiable (Hirschheim & Klein 1989), knowledge should be emanated from reality through observables. The knowledge is then evalu-

ated through a hypothetic-deductive reasoning with which hypotheses that speculate the outcome of a research model could conceivably be falsified by a test on observable data (Chen & Hirschheim 2004). However, knowledge is not considered as a constantly accumulating entity with imperfect theories refuted by more adequate theories.¹⁰ This implies that theories that have been successful for making predictions are fundamentally inconclusive (Hunt 1991) and thus leave room for changes in the current orthodoxy about distinct concepts and research problems that direct research efforts (see Kuhn 1962).

In directing research efforts, it must be stressed that epistemological position allows the use of different methods by which knowledge is to be generated (Hunt 1991; Klein 1999). “It may be completely acceptable and logically stringent to use quantitative methods from an interpretivist viewpoint or to use semi-structured interviews from a positivist viewpoint.” (Stahl 2008, 83) It is the conclusions that reflect the ontology underlying each epistemological position as adopting the same method can produce the exact same results. Therefore, we acknowledge that different methods of research in one paradigm are applicable to inform or advance research in another, including positivism (Goles & Hirschheim 2000; Schultz & Hatch 1996).

In conclusion, we follow positivism as it best suites to our research goals and interests, that is, developing a theory-based research model and test its applicability within VW domain. The research method adopted for this dissertation will be discussed in detail below.

3.2 Survey method

Based on the opinion research design, which concerns gathering information on attitudes, perceptions, and beliefs of human subjects (Jenkins 1985), we use a survey as our research method (Figure 8). This is due to its ability to answer “how” and “why” questions, and as argued by Pinsonneault and Kraemer (1993), a survey is especially warranted for collecting standardized information on respondents’ views via predefined questions. Further, the nature of

¹⁰ One does not know with certainty, therefore, inductive proof is logically untenable (Hunt, 1990).

our survey is explanatory since our aim is not only to identify the beliefs driving continual use intention, but to also test their mutual relations against a large sample of data recorded in a natural setting.

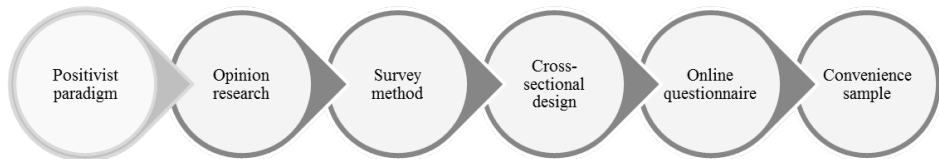

Figure 8 Empirical design

The survey design is cross-sectional, indicating that the data is collected at a specific point in time. In comparison to longitudinal survey, it requires less time and effort but blurs the temporal patterns in causal associations. This typically questions its use in modeling of the cause and effect. However, a longitudinal design is not a prerequisite for our research model. Collecting the data at one point in time is further justified by the fact that our research emphasis was not on the temporal adjustment of the selected constructs but their relationships.

To collect data, we preferred an online questionnaire, which we conducted using Webropol software¹¹. The benefit of an online questionnaire is attributable to three factors. First, it allows us to easily and inexpensively create the survey instrument and post it on a selected site or send it by email to recipients. Second, the responses could be automatically saved in an electrical format to facilitate analysis. Third, and most importantly, the method helps us to directly reach out to actual VW users, the population of interest in this dissertation. This is further supported by the notion that postal addresses or telephone numbers are not strictly required during the registration process, which makes mail and telephone surveys less desirable.

¹¹ www.webropol.com.

For the survey, a convenience sample was selected over random sample for two reasons. First, we wanted to build confidence among the respondents, and, therefore, respected their full anonymity. In doing so, the respondents remained anonymous to the researchers themselves, making random sample beyond reasonable efforts. Second, while VW operators require new users to provide an email address, which must be verified before allowing access to their platforms, the database can contain non-active or duplicate inputs and, thus is not up-to-date. This stems from challenges that concern recording new emails created just for registration purposes (i.e., dead user accounts), allowing people to have many user accounts (i.e., duplicates), or encouraging users to update their contact information when changes occur (i.e., false information). Such issues are likely to threaten the external validity of the random sample due to poor representativeness (Sheehan 2001). We acknowledge that convenience sample is also problematic since it favors those willing to participate (Wright 2005). Given our research focus, such eminent activity is, however, assumed to make their opinions especially valuable. Hence, we believe the non-randomized approach is not a major sphere of concern.

3.3 Implementation process

Through comparison between various VWs, we decided to collect data for our dissertation from real users of Habbo Hotel. With 273 million registered users to date (Sulake Corporation 2012), Habbo Hotel is regarded as one of the most popular and widely acknowledged teen- and pre-teen-oriented VWs. Offering access through 11 language portals, Habbo Hotel has succeeded in rapidly increasing its customer base. Yet the VW is having a hard time encouraging their users return to their system.

Currently, Habbo Hotel customers between 13 and 18 years old account for 90% of the overall base, with the gender distribution being nearly equal (Sulake Corporation 2012). Although its user interface has borrowed its retrospective design from older computer and console games (see Figure 9), Habbo Hotel diverges from true gaming VWs (e.g., World of Warcraft) in that the designer-produced, progressively advancing storyline is replaced by user-determined objectives and occasional activities and events promoted by the operator. Habbo Hotel provides an extensive environment, which translates into countless virtual cafés, parks, and user-generated private rooms, within which users can interact with one another and play various non-violent in-world games.

We ground our choice of research site on two rationales. First, Habbo Hotel has received far less attention than other VWs (Second Life in particular) in extant VW studies (e.g., Animesh et al. 2011; Goel et al. 2013; Zhou et al. 2012). Second, as opposed to these VWs, the majority of the Habbo Hotel user base consists of young people who also make the largest customer group in VW domain (kZero 2012). Accordingly, we believe studying Habbo Hotel not only helps us bridge the research gap between adults and the young but is also of particular interest in terms of gaining new insights into continual VW use. While there are other VWs for young people (e.g., Club Penguin, Stardoll, Poptropica, etc.), we decided to restrict our analysis to Habbo Hotel only. This allowed us to have a fundamental understanding of the site and to avoid compromising the adopted measurements.



Figure 9 A snapshot of the Habbo Hotel lobby

For our dissertation, we focused on the users of the Finnish Habbo Hotel, implying that the culture of the respondents was tied to Western values. By including only one portal into our analysis, we wanted to avoid potential distortion in the findings as each of the eight portals from which we received the data differs – albeit slightly (undifferentiated user interface) – in content and features. The reason for selecting the Finnish portal is extended by the fact that it serves as a platform for adding and testing new features with actual users

before being released on other portals. As such, we believe the portal exemplifies the future behavior of the larger population.

The questionnaire was first constructed in English. Before releasing the pilot study, which tested the feasibility of the constructs and comprehension of the questionnaire, it was checked by a professional English translator. The pilot study was then carried out. Some minor refinements were made to the questionnaire. For example, to guard against the respondents' lack of motivation, we adjusted the materialization of the questionnaire. Then, the questionnaire was translated into Finnish, that is, the language in which it was to be administered. Finally, the questionnaire was double-checked by a professional translator.

The instrument contained some socio-demographics and a selection of measures (i.e., constructs) relevant to this dissertation. All measures (see Appendix 3) were drawn from established and validated measurement scales (Boudreau, Gefen & Straub 2001).¹² To match the measures to the context of our research setting, and to form them in a way they were more understandable with regards to the young respondents' development level, their original wording was made simpler and less ambiguous (e.g., "the system" was changed into "VW name."). Negative wording was used sparingly, although adolescents are shown to cope with such questions better than younger children (Benson & Hocevar 1985; de Leeuw & Collins 1997).

The measures contained worded multi-item scales on a 7-point Likert-scale, anchoring from strongly disagree to strongly agree, aside from the measure concerning critical mass, which was anchored from none to all. Apart from the construct measuring referents' influence (Hsieh et al. 2008) adopted in the second research article, all measures within this dissertation were reflective in concept, indicating that (latent) constructs were independent of the observed items (Borsboom, Mellenbergh & van Heerden 2003; Diamantopoulos & Winklhofer 2001). The change in the observed items reflected the change in the

¹² Measurement items adopted in this dissertation differ marginally across the articles. This is due to the fact that each of the articles represents a distinct research perspective, which influences the selection of the measures. Since only cases relating to each set of measures with full responses were included, the results of the validation process – i.e., which measurement items were used – also vary across the articles. The adjustment in item selection provides us with the necessary convergent and discriminant validity required for any measures (Fornell & Larcker, 1981).

constructs, making the causality to flow from the construct to the observed items (Coltman, Devinney, Midgley & Venaik 2008; Jarvis, MacKenzie & Podsakoff 2003). Hence, adding or dropping one of the observed items should not change the disposition of the construct (content validity through theoretical consideration).

The actual questionnaire was made available on the home page of the target portals for one week in July 2008. To do that, final permission to run the survey was obtained from the VW operator. Before logging in, users were confronted with a hyperlink leading to a starting message in which respondents were briefly informed about the study (Appendix 2). Participating in the research was completely voluntary and based on informed consent. No incentive of any kind was offered. It was also underlined that at any time while completing the questionnaire, the respondents were free to withdraw from the study. Multiple responses from the same IP address were not accepted.

Bearing in mind that the respondents of this study were mainly adolescents (mostly teenagers), we paid extra attention to minimize causing any harm to them. Except for questions about gender and age, no identifiable personal information (e.g., user names, etc.) was collected. Also, our study did not contain sensitive topics that are seen to increase barriers to adolescents' participation. Therefore, we decided to ensure respondents' autonomy, which obviated the need for parental approval. It is also to be noted that requesting such approval would have offended the adolescents' right to confidentiality. The approach adopted here complies with the guidelines set by the national advisory board on research ethics in Finland, according to which researchers cannot be assumed to automatically request parental approval when research involves minors.

3.4 Data analysis

During the one-week period (July 21st – July 28th) the survey¹³ was accessed 62,395 times and data was acquired from a total of 31,284 respondents, re-

13 The survey included a total of eight country portals: Brazil, Canada, Finland, France, Germany, Spain, UK and USA.

sulting in a response rate of 50.1%. Of those, 3,265 (10.4%) were respondents using the Finnish portals. The local response rate was 36.6% (page impressions: 8,918).

The data was screened using AMOS (PASW) Statistics software. According to results obtained from all portals, an average Habbo Hotel user is male, aged between 13–18 years, and has gained system experience of one to three years. A majority of the Finnish respondents in turn was rather young females, implying that the Finnish sample was biased towards young, mostly female, rather experienced Habbo Hotel users. To screen for potential non-response bias, a comparison between early and late respondents (Grover, Lee & Durand 1993) was made. The t-test detected no significant differences. Also, we compared the data with the available user survey (Habbo Hotel 2008), and again, we found no large demographical discrepancies. User demographics for our sample are shown in Table 5.

Table 5 Respondent information

		All (n=31,284)		Finnish (n=3,265)	
		Frequency	Percent	Frequency	Percent
Gender	Female	13,098	41.9	1,860	57.0
	Male	17,705	56.6	1,347	41.2
	Missing	481	1.5	58	1.8
Age	Pre-teens (<13)	5,853	18.7	1473	45.1
	Teens (13–18)	22,855	73.1	1,623	49.7
	Adults (>18)	2056	6.6	110	3.4
	Missing	520	1.6	59	1.8
System experience	< 1 month	2,278	7.3	112	3.4
	1–6 months	6,620	21.2	293	9.0
	6–12 months	4,507	14.4	252	7.7
	1–3 years	11,045	35.3	1,207	37.0
	> 3 years	5,985	19.1	1,309	40.1
	Missing	849	2.7	92	2.8

The data contained a rather large number of missing or incomplete responses. The refusal to fully complete the questionnaire sprang supposedly from the relatively long questionnaire.¹⁴ This was verified through missing value analysis. To ensure the best quality of our data and the research articles, only fully completed responses were included for further analyses. The final sample sizes differ across the articles due to varying inclusion of criteria and variables (Table 6).

Table 6 Responses per article¹⁵

	Article 2	Article 3 ¹	Article 4
Portal		Finnish	
Fully completed responses	1,225	921	2,175
Final response rate (%)	13.7	10.3	24.4

¹ Only respondents aged 13–18 were analyzed.

To test the theory-based relations between the adopted constructs we continued with structural equation modeling (SEM) (Jöreskog & Sörbom 1993; Schumacker & Lomax 2004). Given our relatively large sample sizes with moderate non-normality¹⁶ and that we wanted to test the models in terms of both its predictive validity and fit with the empirical data (Anderson & Gerbing 1988), a covariance-based, maximum likelihood estimation (MLE) approach was preferred over a component-based approach (Hu, Bentler & Kano 1992; Tabachnick & Fidell 2007). To this end, AMOS software was employed in the second and third research articles. The fit-indices, of which nearly all signaled a good model fit, are summarized below.

¹⁴ The authors would like to underline that the questionnaire was built to fulfill two different research objectives. Part of a corpus of data has been used as a source for another author's (Matti Mäntymäki) doctoral dissertation (2011).

¹⁵ The first article was conceptual, and, therefore, no data were available.

¹⁶ According to Bollen (1989), all normal distribution estimations methods, including maximum likelihood, are consistent even if the assumption of normality is moderately violated. The test for normality showed that while kurtosis was not an issue (<3.0), few observed variables gave skew distributions higher than 2.0 (Finney & DiStefano, 2006; Hoogland & Boomsma, 1998).

Table 7 Measurement model fit indices (articles 2 and 3)

Fit index	Purpose	Article 2	Article 3	Cutoff value	References
CFI	Model comparison	0.962	0.965	≥ 0.90	Anderson and Gerbing (1988)
CMIN/DF	Model to sample	5.152	3.075	< 5.0	Wheaton et al. (1977)
GFI	Model to sample	0.921	0.907	≥ 0.90	McDonald and Ho (2002)
RMSEA	Model comparison	0.058	0.047	< 0.07	Steiger (2007)
SRMR	Model to sample	0.088	0.046	< 0.08	Hu and Bentler (1999)
TLI	Model comparison	0.954	0.959	≥ 0.90	Hu and Bentler (1998)

Since the fourth research article focused on predicting continual VW use intention without having an established theoretical reference derived from previous publications, we considered the component-based PLS (partial least squares) as a practical method and utilized the software package SmartPLS (Chin 1998; Fornell & Bookstein 1982; Ringle, Wende & Will 2005; Sosik, Kahai & Piovoso 2009). The selection is further justified on the basis that PLS is considered highly robust for confirmatory analysis across different model characteristics (e.g., Hair, Sarstedt, Ringle & Mena 2012). For this analysis, we applied the bootstrapping technique (500 re-samples) to estimate the standardized path coefficients and explained variances. Two-tailed t-tests were conducted to assess the significance of the path effects. Overall, the results strongly confirm the predictive power of the model. The amount of variance explained was rather high, implying a good fit to the data.

To assess the validity and reliability of all measures adopted we used convergent validity by computing and examining composite reliabilities, Cronbach's alphas, average variance extracted (AVE), and factor loadings. Convergent validity was re-confirmed as all indicator-factor loadings exceeded the value of 0.70, all Cronbach's Alphas and the composite reliability scores exceeded the advocated values of 0.80, and the AVEs were above the 0.50 guideline for reliability (Fornell & Larcker 1981; Ping 2004). Thus, all measures in the empirical research articles included in this dissertation (see Appendices 4–6) performed well and met the criteria for convergent validity.

To conclude the tests for discriminant validity, we investigated whether the AVE for each construct was higher than the squared correlation between it and all other constructs (Fornell & Larcker 1981). The discriminant validity is demonstrated in appendices 7–9. Although the test for discriminant validity of the measurement model was met, we noticed a rather high correlation of the two decomposed beliefs within the perceived behavioral control block. In retrospect, based on the empirical evidence from prior IS adoption studies em-

ploying DTPB (cf. Hsieh et al. 2008) as well as TPB-based studies in general (Armitage & Conner 2001), this higher inter-construct correlation was anticipated. However, we only used measures tested in the established literature; and given that the AVEs did strictly exceed the squared correlations between the constructs, the overall fit indices of the measurement model also suggested discriminant validity. Hence, a lack of discriminant validity was unlikely to be an issue. Still, to examine the issue further, we investigated item cross-loadings. Each item loaded higher on its intended construct than any other constructs, thereby providing additional support for discriminant validity (Fornell & Larcker 1981). Furthermore, since the construct reliabilities were high (> 0.80) and the sample size was large, these characteristics supported the notion that a sufficient level of discriminant validity was achieved (Grewal, Cote & Baumgartner 2004).

Finally, since a cross-sectional self-administered questionnaire was used, we examined the risk for common method bias (CMB), which is “variance that is attributable to the measurement method rather than to the constructs the measures represents.” (Podsakoff, MacKenzie, Lee & Podsakoff 2003, 879) To study whether systematic measurement error existed (e.g., consistency motive and social desirability: Bagozzi & Yi 1991; MacKenzie & Podsakoff 2012), we first performed Harman’s single-factor test for each indicator (Podsakoff & Organ 1986), a diagnosis which indicated no substantial amount of common method variance. Given the test has been criticized for being overly insensitive (Podsakoff et al. 2003), we continued with the common latent factor test, which examines “the significance of the structural parameters” with and without the common latent factor (Podsakoff et al. 2003, 892). To adapt the test to a component-based approach (the fourth article) we followed Liang, Saraf, Hu and Xue (2007) and Sipponen and Vance (2010) and converted each indicator in the measurement model to a single-indicator construct. The tests indicated that CMB is not likely to distort our results.

3.5 Results of the articles

The first research article (Merikivi & Mäntymäki 2009) proposed an initial research model. Based on prior IS literature, and following TPB (Ajzen 1991), the article identifies attitudinal, normative, and control beliefs that drive continual VW use. The article holds that VWs afford hedonic, utilitarian, and social outcomes. To make use of the VWs, users have to stomach interpersonal and external influence and to learn how to control the environment. That is, while the article provides no empirical evidence, it proposes that continual

VW use intention is determined by constructs which capture the effects of attitudinal, normative, and control beliefs.

To add to the assumptions made in the first research article, the second research article (Merikivi 2009) makes a deep-seated effort to test and validate the model against empirical data. Leaning on the mapping (social, hedonic, and utilitarian outcomes) described in the previous article and the dichotomy of motives (Ryan & Deci 2000a), the proposed research model identifies and decomposes attitudinal beliefs into six constructs. To do this, it exemplifies DTPB (Taylor & Todd 1995a). Two major findings were observed. First, the results support the explanatory power of the model. Attitudinal beliefs explained 52 percent of the variance in the attitude. Second, the attitude itself was primarily shaped by enjoyment (0.52) and only moderately by playfulness (0.13) and social presence (0.12). The two latter loadings were clearly weaker than those seen in other studies (e.g., Schwarz et al. 2012). Furthermore, the unexpected insignificance of connectedness, uniqueness, and status indicates that social motives, both extrinsically and intrinsically, associated with VW use are of little value to users. Taken as a whole, VW users look for enjoyable activities, usually in the form of appealing environmental attributes.

The third research article (Mäntymäki et al., in review) prompts more investigation into how, and to what extent, attitudinal, normative, and control beliefs influence continual VW use intention. Based on the previous results and more rigorous theoretical grounds, the study proposes an integrated model built on DTPB. The model provides us with two key results. First, the TPB constructs explained 46 percent of the variance in the continual VW use intention. The results demonstrate that attitude (0.35), subjective norm (0.29), and perceived behavioral control (0.32) have a direct and significant influence on continual VW use intention. Second, all decomposed beliefs added to their respective higher-order constructs. Intrinsic motive (0.64), interpersonal influence (0.62), and self-efficacy (0.66) were the most secure indirect determinants of continual VW use intention. This yields a notion that a VW is enjoyable and comfortable to use and is supported by the positive opinions of friends and other referents. Contrary to the study of Verhagen et al. (2012), perceived usefulness was found to have a very weak effect on attitude. In conclusion, decomposing belief structures seems to contribute to our understanding of continual VW use intention and that they correspond with the findings noted in prior research (Taylor & Todd 1995a).

The last of the research articles (Merikivi et al. 2012) completes our dissertation by forming direct paths between the attitudinal, normative, and control beliefs and continual VW use intention. To that end, a more direct approach based on DTPB was applied. Overall, our data highlights two major findings.

First, the predictive power of the direct model is strongly confirmed. The amount of variance explained (54%) was rather high, implying a good fit to the data. Second, except for social (i.e., interpersonal) influence, all decomposed beliefs contributed to the approach. However, only enjoyment (0.38) exerted a convincing influence on continual VW use intention, the other loadings falling under the threshold value of 0.20 (Chin 1998). Our results are in partial contradiction with prior VW studies (e.g., Barnes 2011) that found a direct and significant positive relationship between perceived usefulness and continual VW use intention. In conclusion, the results indicate that users are likely to engage in VWs that are seen to deliver enjoyment.

To ensure high predictive validity of the results, only constructs with standardized paths being at or above the threshold value (0.20) set by Chin (1998) were included in the integration model. The integration model is depicted in Figure 10.

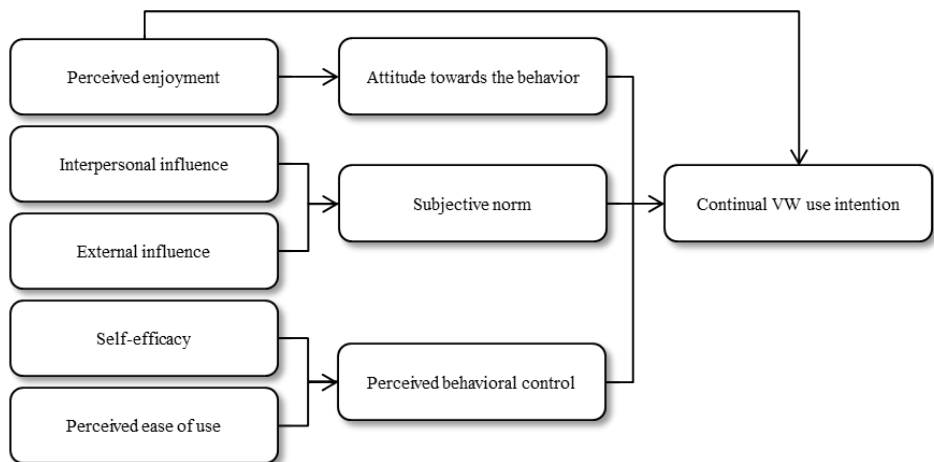

Figure 10 An integrated model for continual VW use intention

4 DISCUSSION AND CONCLUSION

The last section will first list the key findings to draw together the empirical findings of this dissertation. It then continues with the implications of the findings. Finally, conclusions and limitations as well as the areas for future research are discussed.

4.1 Key findings

The primary goal of this thesis was to investigate why young people continue using VWs. To this end, we developed and tested the value of a decomposed approach in explaining continual VW use intention. Four key findings of this thesis respond to our research questions (see Table 8).

First, the empirically demonstrated predictive value of the decomposed approach was rather convincing. The amount of variance explained by the revised models in the continual VW use intention (44–54%) supports the use and further investigation of the DTPB approach in VW domain. Second, the findings corroborate the importance of all TPB constructs: Attitude is the strongest determinant of continual VW use intention, followed by perceived behavioral control, and subjective norm. This indicates that while building on their own conception and controllability, users do perceive some social pressure when deciding on their future VW use. The significance of attitude in post-adoption settings is consistent with existing IS and VW studies (Hsieh et al. 2008; Schwarz et al. 2012). Perceived behavioral control is also a relevant and expected determinant of continual VW use intention (Lee & Tsai 2010). The significance of subjective norm for continual VW use intention is in conflict with the previous findings (e.g., Hsieh et al. 2008; Karahanna, Straub & Chervany 1999). Still, given the multi-user context, we expected social pressure to be even more influential. The effect may be corrupted due to the reason that revealing one's real-life identity is prohibited inside Habbo Hotel to protect its users: Such protection might make the users feel more comfortable in making their decisions autonomously, thereby lending support to the leading role of attitude. Third, the findings confirm that the beliefs adopted here strongly influence their respective TPB components, suggesting that the de-

composed approach integrating the more parsimonious approaches (e.g., TAM, TRA and TPB) adds to our understanding of continual VW use intentions. Specifically, perceived enjoyment, interpersonal influence, and self-efficacy was demonstrated to exert particularly strong effects on their corresponding endogenous constructs and can thus be labeled as compelling indirect determinants of continual VW use intention. Interestingly, connectedness, perceived usefulness, and status were peripheral in influencing continual VW use intention, a finding that cautions against the assumption that VWs are multipurpose by definition (Verhagen et al. 2009). Finally, the findings confirm that only perceived enjoyment influences continual VW use intention directly. Perceived critical mass was entirely irrelevant to VW users' continual use intention. While these results partially correspond with prior VW research (Barnes 2011), advocating a more direct approach, the original structure of DTPB seems applicable.

To sum up, the provision of an enjoyable and comfortable user experience – processed mostly through conscious evaluation – and that it is supported by the positive opinions of friends and other referents, is likely to make users continue using VWs.

Table 8 Answers to the research questions

Level	Research question	Answer
Article 1	What are the beliefs that influence continual VW use intention?	Continual VW use is suggested to be determined by all attitudinal, normative, and control belief types.
Article 2	What motivates people to continual VW use?	Young VW users are driven by intrinsic motives, extrinsic and social motives are trivial.
Article 3	How, and to what extent, do attitudinal, normative, and control beliefs influence continual VW use intention?	The results corroborate the importance of attitude as the strongest determinant of continual VW use intention, followed by perceived behavioral control, and subjective norm.
Article 4	How, and to what extent, do attitudinal, normative, and control beliefs directly influence continual VW use intention?	Only enjoyment (attitudinal belief) has a sound direct effect on continual VW use intention.
Thesis	Why do people continue using VWs?	The provision of an enjoyable and comfortable user experience – perceived either spontaneously or through conscious evaluation – and that it is supported by the positive opinions of friends and other referents, is likely to make users continue using VWs.

4.2 Implications for theory

From a theoretical standpoint, our study adds to the understanding of continual VW use in several ways.

The empirical results confirm the predictive value of DTPB, which has not yet been included in the empirical discourse within the VW literature. Further, DTPB demonstrates that attitude, subjective norm, and perceived behavioral control jointly influence continual VW use intention. This makes DTPB a theoretically grounded research gate for understanding continual VW use. Most notably, its flexibility opens up the left-hand side of the decomposed approach for an in-depth analysis. Here, we integrated three auxiliary theories (self-determination theory, innovation diffusion theory, and social cognitive theory) in DTPB to decompose attitude, subjective norm, and perceived behavioral control. Such an adaptable layout not only makes DTPB more preferable over the more parsimonious approaches (cf. Taylor & Todd 1995a) for investigating complex systems, such as VWs, but also adds to its generalizability (Berthon et al. 2002).

Our dissertation puts forward three principal beliefs that drive continual VW use intention. Perceived enjoyment was the most influential (attitudinal) belief. More surprisingly, the influence of extrinsic motives, such as perceived usefulness, status, and uniqueness were marginal, reflecting that VW users prefer the pleasure-oriented nature over utility. Strictly speaking, this contradicts with the MPIS approach, according to which different motivational types are relevant to system users (see e.g., Verhagen et al. 2012). This finding should be greeted with cautious optimism. Recognizing that the extrinsic benefits of our dissertation are related primarily to communication, and its value seems depreciated, possibly due to the fact that users congregate on other social networks (see also Huang & Hsieh 2011; Takahashi 2011). Also, it is likely that other aspects of extrinsic motive may be more salient for VW users. Within Habbo Hotel, communicating is recognized as being just another activity alongside and equal to those of furniture trading or playing competitive games (cf. Huang & Hsieh 2011). A third possible avenue of reasoning follows the developmental perspective which holds that the young are intrinsically biased in their behavior (Harter 1981). This is supported by the fact that VWs towards adults (e.g., Second Life) are high in both extrinsic and intrinsic attributes (Barnes 2011).

Most alarmingly, and contrary to previous studies, which report that social aspects explain VW use (e.g., Hsiao & Chiou 2012; Jung & Kang 2010; Karjaluoto & Leppäniemi 2013), our findings show that Habbo Hotel fell short in strengthening connectedness among its users. Two possible scenarios can be

envisioned. First, the system regulations, which promote anonymity, encourage the users to interact mainly either with strangers or new acquaintances, or with friends they do not believe care about their well-being, leading to a state in which connectedness cannot be attained (Baumeister & Leary 1995). As a result, the interaction among VW users includes a mere one-off exchange of information, and, thus, supportive social relationships fail to emerge. Second, the system discounts social presence. The explanation is supported by Riedl, Köbler, Goswami and Krcmar (2013) who demonstrate that social presence of other users is an imperative building block for connectedness. Given the insignificance of social presence in our study, this explanation seems plausible. However, further research and theorizing is needed to fully grasp the social aspects and the underlying mechanisms that dictate continual VW use.

The findings show that self-efficacy is the second strongest (control) belief. Obviously, VW operators have been influential in making the navigational element more user friendly (Goel et al. 2011), and the results of this study indicate that these goals have largely been achieved. As most current VWs are relatively easy to use, the perception of this system capability is less likely to be a dominant determinant of behavioral constructs (cf. Vijayasathy 2004). Self-efficacy, which also reflects the unpredictability of confrontations with other users, had a more sound effect on perceived behavioral control. From this perspective, perceived behavioral control seems to depend heavily on its inhabitants, thus swaying the balance towards self-efficacy, that is, a comfortable usability experience. Interestingly, the importance of self-efficacy questions young people's inherent ability to use information technology (Prensky 2001). The findings demonstrate that young VW users gain self-confidence through experience. Given the relative significance of perceived behavioral use (see also Huang & Hsieh 2011), we encourage further development of social theorizing in order to increase the comfortable usability of VWs, as well as other topics that elevate user self-efficacy.

Interpersonal influence (referents) is the third strongest (normative) belief, much stronger determinant of action in VW domain than external influence (mass media) or perceived critical mass. (A post hoc analysis revealed that perceived critical mass did not substantially affect the subjective norm, a finding that promotes quality over quantity in one's social network.) Besides being in compliance with prior research in that the young adjust their behavior to their referents' views (Youniss & Smollar 1985), the result suggests the excellence of word-of-mouth advertising in reaching online audiences as suggested by Brown et al. (2007). This in turn helps determine online user behavior, which is in line with the findings of Gruen, Osmonbekov, and Czaplewski (2006).

Finally, partially consistent with some prior VW studies (e.g., Barnes 2011; Huang & Hsieh 2011), our findings indicate that only perceived enjoyment had second-order influences on continual VW use intention. The dualistic influence of perceived enjoyment can be explained by the level of involvement. In situations where people are having a total experience with the system, no further evaluation is conceivable or necessary (i.e., absorption: Agarwal & Karahanna 2000). However, in a state of less than all-powerful yet enjoyable involvement users engage in a more detailed evaluation of their actions. For example, one may enjoy winning an arcade game but simultaneously fear of upsetting their contestants. In this connection, it seems the underlying beliefs are not influential alone. Rather, users appear to mostly base their intentions on a deliberate evaluation process, which adds to the significance of the TPB constructs and cautions against excluding them from models investigating continual IS use behavior in VW domain (I. Ajzen, personal communication, 14 December 2012). While our dissertation is one of the first to compare the indirect and direct effects of beliefs on continual use intention within VW domain, further research is warranted.

In sum, given our objective, we hold that our dissertation makes three key theoretical implications to continual IS use behavior and VW literature. The implications are summarized in Figure 11.

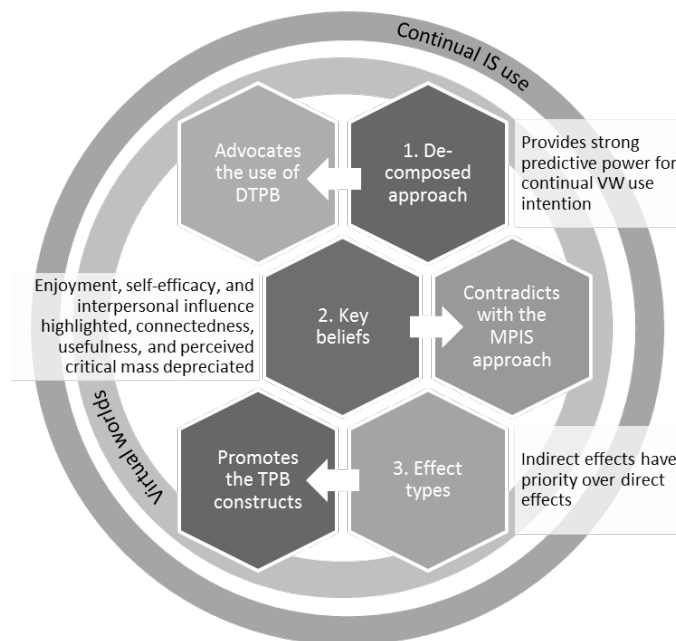

Figure 11 Summary of theoretical implications

4.3 Implications for practice

The dissertation offers some beneficial practical implications for anchoring existing users towards continual VW use.

Our dissertation demonstrates that VW operators can benefit from developing and implementing enjoyable enhancements to their systems. In Habbo Hotel, users willing to explore their creative side can already decorate their own rooms and design in-world games to make their stay more enjoyable. However, to make designing games and rooms even more interesting, we encourage the operators to combine intrinsic and extrinsic motives, as per MPISSs. For example, a traffic counter or user rankings may promote enjoyable user experiences when used as a basis for creating a program on social rewards. A user that succeeds in attracting a certain number of individuals to their rooms and games will be rewarded and brought to public attention. Another possibility in linking rewards with intrinsic motives is using rewards with monetary value. Currently, Habbo Hotel rewards its users with virtual currency for sustained participation and game play. The virtual currency serves as a medium of exchange. It can be used to purchasing virtual items that are designed the way that users are also able to express their status and uniqueness inside the system. Since these extrinsic incentive types were evidenced as less influential, we advise VW operators to focus on allowing for changing in-world currency into legal tender, an approach comparable to that taken in Second Life. In this way, however, gaming and trading furniture (a very popular and enjoyable activity in Habbo Hotel) can be experienced as controlling: the use becomes instrumental in earning money, gradually making the experience less enjoyable (Ryan & Deci 2000b). Hence, incentives of monetary value, such as coupons offered by partners in cooperation, should be given unexpectedly. Assumed that these two incentive mechanisms promote the enjoyment derived from being engaged in the VW, this progression essentially kills three birds with one stone: The users themselves will spontaneously try to create new content, amass more new users, and use third-party products.

The results point out the value of the ongoing social influences of important individuals on VW users (Spero 2004; Teng et al. 2012). Indeed, the relative insignificance of external influence in shaping social influence indicates that traditional mass media advertising is not very effective. Provided that peers remain the dominant source of effective communication, we advocate VW operators to hold on to peer-to-peer recommendation boards and viral marketing. To better facilitate the interpersonal aspect inside the system we suggest identifying and focusing on peers who are considered key contributors or potential opinion leaders. To support relationship development in the way that continual

intentions are not dependent on the actions of only one or two opinion leaders, VW operators should perhaps reward their users by actively finding similar others. Features that provide their users the means to gather information about the beliefs and values held by other users (e.g., board of likes and dislikes, design contests, etc.), and functions that automatically and explicitly update user profiles based on prior actions and personal preferences are likely to increase the relevance of the social side of VWs.

Our findings draw attention to the need to further develop the control and representation of avatars. The dissertation reveals that the comfort in using VWs is of particular importance: In gaining control over VW use, it is acceptable to the point it does not extensively distract VW users from engaging in the activity itself (Huang & Hsieh 2011; see Novak 2000). The perception of “being in control” serves thus as relevant architectural criterion for VW operators (Jung 2011). At the implementation stage, more attention, should, however, be directed towards features that make VW users feel comfortable rather than those that make VW use easier. This puts forth that VW operators should give up constantly making extreme changes that impedes system use.

4.4 Limitations and future research

Although our findings are encouraging, this study is not without its limitations: the empirical evidence is collected from just one VW and one country. It has previously been demonstrated that distinct system characteristics influence culture and vice versa. This may limit the results from being interpreted flexibly (and compared) to other VWs. Here we have validated our models by making use of a sample of respondents living in Western culture (Finland). Since this is likely to affect the extent to which user perceptions of the system in question influence its use (e.g., Al-Gahtani, Hubona & Wang 2007; Triandis 1989), future research is needed to investigate whether the results will remain replicable in other cultural settings as to provide a more comprehensive and applicable portrait of continual VW use.

While Habbo Hotel is among the most popular VWs worldwide, it has a limited user base in terms of their users’ demographical patterns, which affects the generalizability of our findings (see Cook & Campbell 1979). This is due to the use of surveys from a younger age group, and although it does not affect the primary goal of our dissertation, we suggest including surveys of adult users. By doing so, it could put the rather insignificant influence of extrinsic motives into perspective (cf. Barnes 2011). Also, the gender bias towards young women in our sample may have influenced our findings. There is evidence

supporting our findings (Mäntymäki et al., in review) that females tend to be less task-focused than males and use systems more for enjoyment (Richard, Chebat, Yang & Putrevu 2010), which might have tilted the balance between perceived enjoyment and usefulness towards the former. A line of future research could address these issues.

Another limitation of our dissertation is that it relies on a short-term snapshot of continual VW use intention, not *actual* use. Acknowledging that intervening factors not studied here may generate changes, and, thus weaken the accuracy of continual VW use intentions to predict actual use, we suggest longitudinal approaches, as they would determine the validity of our models and findings over time. The users are expected to engage in VWs at different times and for various reasons. When the appropriate measures are discovered, a longitudinal study examining post-adoption behavior may provide a better understanding of the users' motives, their intentions, and actual use. Also, there is a challenge compounded by the survey with its distribution limitation. As a result of the online format, we were unable to randomize the sample, so the respondents who took the survey may be different from those who did not in terms of their enthusiasm. A randomized sample would have required a complete list of all the registered users of the Habbo Hotel population, which was not possible and would have endangered the respondents' anonymity. Yet, we believe that a convenience sample gives us reasonable estimates of continual VW use in its preferred forms, as our focus was on the active users.

The theoretical approach we applied within our dissertation differs from the *modus operandi* recommended by researchers in social psychology (Ajzen 1985; 1991). That is, the constructs included in our dissertation were selected from prior literature through an analytic process consistent with Taylor and Todd (1995b). Another potential alternative is to empirically elicit the constructs from the respondents. This requires a qualitative questionnaire for preliminary research, which for our dissertation was not possible. While the predetermined constructs were pilot-tested and the predictive validity of our models was more than acceptable, one must note that the set of constructs is by no means complete.

In offering avenues for further extensions and refinements, five main areas of focus arise from our dissertation. The first of which is, since content and friend invitations represent key means by which VWs can acquire new users, viral advertising can become pivotal in fostering future directions in IS research on social networking applications. Second, our dissertation highlights the importance of intrinsic motives in keeping VW users active. Hence, qualitative research that can uncover the elements that determine such experience would certainly be insightful. For instance, the perception of enjoyment is

shown to draw on the visual attractiveness of the system (the degree to which an individual believes that an information system is aesthetically pleasing to the eye (van der Heijden 2003, 544)) and the avatar-mediated activities (Schwarz et al. 2012). Third, should the construct of interpersonal influence be qualitatively elaborated, it would yield valuable information about the influence of online, compared to offline, friends within social networking applications. Fourth, further research could focus on exploring the relationships among the decomposed beliefs. As previously investigated in the context of technology acceptance research, ease of use has a direct impact on perceived usefulness (Davis et al. 1992). This empirical evidence suggests that additional relationships exist among other decomposed beliefs. The identification of such relationships has already begun (Verhagen et al. 2012), but the research in this field is still in its infancy. Fifth, given that we found both direct and indirect influences on continual VW use intention, a follow-up on evaluation constructs could better actualize our findings. Finally, a research on the divergence of behaviors that takes place inside VWs is suggested because VWs today, carry out a broad inventory of activities, such as education, gaming, and shopping (Jung & Kang 2010); but no research efforts were made to map between these behaviors and the general construct of system use. We believe such a course in research will generate a more thorough understanding of the varying behaviors regulating continual VW use and the multipurpose nature of ISs in general (Hong & Tam 2006; Verhagen et al. 2009).

4.5 Conclusion

The uncertainty that prevails in VW domain has given rise to the need to examine why people continue using VWs. We have dealt with the issue by applying DTPB. Using Habbo Hotel as an example, we have empirically demonstrated the applicability of the decomposed approach. Our extension reveals that continual VW intention use is indirectly influenced by attitudinal (perceived enjoyment), control (self-efficacy and perceived ease of use), and normative beliefs (interpersonal and external influence), in that order. Perceived enjoyment also had a direct positive influence on continual VW use intention. The findings indicate that while the young VW users invariably call for enjoyment, they also value system controllability. Interestingly, users do not perceive VWs as multifunctional or outstandingly communal by definition. On this score, we hope our findings encourage VW operators and designers to upgrade their systems' social, as well as utilitarian, characteristics in extending their long-term VW use.

REFERENCES

- Aarts, H. – Verplanken, B. – Van Knippenberg, A. (1998) Predicting behavior from actions in the past: Repeated decision making or a matter or habit? *Journal of Applied Social Psychology*, Vol. 28 (15), 1355-1374.
- Agarwal, R. – Karahanna, E. (2000) Time Flies When You're Having Fun: Cognitive Absorption and Beliefs about Information Technology Usage. *MIS Quarterly*, Vol. 24 (4), 665-694.
- Agarwal, R. – Sambamurthy, V. – Ralph, M. S. (2000) Research report: The evolving relationship between general and specific computer self-efficacy – An empirical assessment. *Information Systems Research*, Vol. 11 (4), 418-430.
- Ajzen, I. (1985) From intentions to actions: A theory of planned behavior. In: *Action Control: From Cognition to Behavior*, ed. by J. Kuhl – J. Beckmann, 11-39. New York, NY: Springer Verlag.
- Ajzen, I. (1991) The Theory of Planned Behavior. *Organizational Behavior and Human Decision Processes*, Vol. 50 (2), 179-211.
- Ajzen, I. (2002a) Perceived Behavioral Control, Self-Efficacy, Locus of Control, and the Theory of Planned Behavior. *Journal of Applied Social Psychology*, Vol. 32 (4), 665-683.
- Ajzen, I. (2002b) Residual Effects of Past on Later Behavior: Habituation and Reasoned Action Perspectives. *Personality and Social Psychology Review*, Vol. 6 (2), 107-122.
- Ajzen, I. (2005) *Attitudes, personality, and behavior*. Open University Press: Maidenhead.
- Ajzen, I. – Fishbein, M. (1973) Attitudinal and normative variables as predictors of specific behavior. *Journal of Personality & Social Psychology*, Vol. 27 (1), 41-57.
- Ajzen, I. – Fishbein, M. (1980) *Understanding attitudes and predicting social behavior*. Prentice-Hall: Englewood Cliffs: NJ.

- Al-Gahtani, S. S. – Hubona, G. S. – Wang, J. (2007) Information technology (IT) in Saudi Arabia: Culture and the acceptance and use of IT. *Information & Management*, Vol. 44 (8), 681-691.
- Anderson, J. C. – Gerbing, D. W. (1988) Structural Equation Modeling in Practice: A Review and Recommended Two-Step Approach. *Psychological bulletin*, Vol. 103 (3), 411-423.
- Animesh, A. – Pinsonneault, A. – Sung-Byung Yang – Oh, W. (2011) An Odyssey into Virtual Worlds: Exploring the Impacts of Technological and spatial Environments on Intention to Purchase Virtual Products. *MIS Quarterly*, Vol. 35 (3), 789-810.
- Armitage, C. J. – Conner, M. (2001) Efficacy of the Theory of Planned Behaviour: A meta-analytic review. *British Journal of Social Psychology*, Vol. 40 (4), 471-499.
- Bagozzi, R. P. (1982) A field investigation of causal relations among cognitions, affect, intentions, and behavior. *Journal of Marketing Research*, Vol. 19 (4), 562-583.
- Bagozzi, R. P. – Yi, Y. (1991) Multitrait-Multimethod Matrices in Consumer Research. *Journal of Consumer Research*, Vol. 17 (4), 426-439.
- Bainbridge, W. S. (2007) The Scientific Research Potential of Virtual Worlds. *Science*, Vol. 317 (5837), 472-476.
- Bandura, A. (1977) Self-efficacy: Toward a unifying theory of behavioural change. *Psychological Review*, Vol. 84 (2), 191-215.
- Bandura, A. (1982) Self-efficacy mechanism in human agency. *American Psychologist*, Vol. 37 (2), 122-147.
- Bandura, A. (1986) *Social Foundations of Thought and Action: A Social Cognitive Theory*. Prentice-Hall: Englewood Cliffs, NJ.
- Bandura, A. (1999) Social Cognitive Theory. *Asian Journal of Social Psychology*, Vol. 2 (1), 21-41.
- Barnes, S. J. (2011) Understanding use continuance in virtual worlds: Empirical test of a research model. *Information & Management*, Vol. 48 (8), 313-319.
- Bartle, R. A. (2004) *Designing virtual worlds*. New Riders: Indianapolis, Ind.

- Baumeister, R. F. – Leary, M. R. (1995) The need to belong: Desire for interpersonal attachments as a fundamental human motivation. *Psychological Bulletin*, Vol. 117 (3), 497-529.
- Bell, M. W. (2008) Toward a definition of 'Virtual Worlds'. *Journal of virtual worlds research*, Vol. 1 (1), 1-5.
- Benbasat, I. – Barki, H. (2007) Quo vadis, TAM? *Journal of the Association for Information Systems*, Vol. 8 (4), 211-218.
- Benbasat, I. – Zmud, R. W. (2003) The Identity Crisis within the Discipline: Defining and Communicating the Discipline's Core Properties. *MIS Quarterly*, Vol. 27 (2), 183-194.
- Benson, J. – Hocevar, D. (1985) The impact of item phrasing on the validity of attitudes scales for elementary school children. *Journal of Educational Measurement*, Vol. 22 (3), 231-240.
- Berthon, P. – Pitt, L. – Ewing, M. – Carr, C. L. (2002) Potential research space in MIS: A framework for envisioning and evaluating research replication, extension, and generation. *Information Systems Research*, Vol. 13 (4), 416-427.
- Bhattacharjee, A. (2000) Acceptance of E-Commerce Services: The Case of Electronic Brokerages. *IEEE Transactions on Systems, Man & Cybernetics – Part A: Systems and Humans*, Vol. 30 (4), 411-420.
- Bhattacharjee, A. (2001) Understanding Information Systems Continuance: An Expectation-Confirmation Model. *MIS Quarterly*, Vol. 25 (3), 351-370.
- Biocca, F. (2000) New media technology and youth: trends in the evolution of new media. *Journal of Adolescent Health*, Vol. 27 (2), 22-29.
- Biocca, F. – Harms, C. – Burgoon, J. K. (2003) Toward a More Robust Theory and Measure of Social Presence: Review and Suggested Criteria. *Presence: Teleoperators and Virtual Environments*, Vol. 12 (5), 456-480.
- Bollen, K. A. (1989) *Structural Equations with Latent Variables*. John Wiley & Sons: New York, NY.
- Borsboom, D. – Mellenbergh, G. J. – van Heerden, J. (2003) The theoretical status of latent variables. *Psychological review*, Vol. 110 (2), 203-219.

- Boudreau, M. – Gefen, D. – Straub, D. W. (2001) Validation in Information Systems Research: A State-of-the-Art Assessment. *MIS Quarterly*, Vol. 25 (1), 1-16.
- Brown, J. – Broderick, A. J. – Lee, N. (2007) Word of mouth communication within online communities: Conceptualizing the online social network. *Journal of Interactive Marketing*, Vol. 21 (3), 2-20.
- Burrell, G. – Morgan, G. (1979) *Sociological paradigms and organisational analysis elements of the sociology of corporate life*. Heinemann: London.
- Castronova, E. (2006) *Synthetic Worlds: The Business and Culture of Online Games*. University Of Chicago Press: Chicago, IL.
- Chaturvedi, A. R. – Dolk, D. R. – Drnevich, P. L. (2011) Design Principles for Virtual Worlds. *MIS Quarterly*, Vol. 35 (3), 673-684.
- Chen, W. – Hirschheim, R. (2004) A paradigmatic and methodological examination of information systems research from 1991 to 2001. *Information Systems Journal*, Vol. 14 (3), 197-235.
- Chesney, T. – Chuah, S. – Hoffmann, R. (2009) Virtual world experimentation: An exploratory study. *Journal of Economic Behavior & Organization*, Vol. 72 (1), 618-635.
- Chesney, T. – Coyne, I. – Logan, B. – Madden, N. (2009) Griefing in virtual worlds. *Information Systems Journal*, Vol. 19 (6), 525-548.
- Cheung, C. M. K. – Chan, G. W. W. – Limayem, M. (2005) A Critical Review of Online Consumer Behavior: Empirical Research. *Journal of Electronic Commerce in Organizations*, Vol. 3 (4), 1-19.
- Chin, W. W. (1998) Issues and Opinion on Structural Equation Modeling. *MIS Quarterly*, Vol. 22 (1), 7-15.
- Chiu, C. – Hsu, M. – Wang, E. T. G. (2006) Understanding knowledge sharing in virtual communities: An integration of social capital and social cognitive theories. *Decision Support Systems*, Vol. 42 (3), 1872-1888.
- Choi, D. – Kim, J. (2004) Why People Continue to Play Online Games: In Search of Critical Design Factors to Increase Customer Loyalty to Online Contents. *CyberPsychology & Behavior*, Vol. 7 (1), 11-24.

- Christopher, R. P. – John, S. H. – Vandebosch, M. (2001) Research report: Richness versus parsimony in modeling technology adoption decisions - Understanding merchant adoption of a smart card-based payment system. *Information Systems Research*, Vol. 12 (2), 208-222.
- Coltman, T. – Devinney, T. M. – Midgley, D. F. – Venaik, S. (2008) Formative versus reflective measurement models: Two applications of formative measurement. *Journal of Business Research*, Vol. 61 (12), 1250-1262.
- Cook, T. D. – Campbell, D. T. (1979) *Quasi-experimentation design & analysis issues for field settings*. Rand-McNally: Chicago, IL.
- Cooper, R. B. – Zmud, R. W. (1990) Information Technology Implementation Research: A Technological Diffusion Approach. *Management Science*, Vol. 36 (2), 123-139.
- Daft, R. – Lengel, R. H. (1984) Information richness: A new approach to managerial behavior and organizational design. In: *Research in organizational behavior: an annual series of analytical essays and critical reviews*, ed. by B. M. Staw – L. L. Cummings, 191-233. Greenwich, CT: JAI Press.
- Davis, F. D. (1989) Perceived Usefulness, Perceived Ease of Use, and User Acceptance of Information Technology. *MIS Quarterly*, Vol. 13 (3), 319-340.
- Davis, F. D. – Bagozzi, R. P. – Warshaw, P. R. (1989) User Acceptance of Computer Technology: A Comparison of Two Theoretical Models. *Management Science*, Vol. 35 (8), 982-1003.
- Davis, F. D. – Bagozzi, R. P. – Warshaw, P. R. (1992) Extrinsic and Intrinsic Motivation to Use Computers in the Workplace. *Journal of Applied Social Psychology*, Vol. 22 (14), 1111-1132.
- De Cannière, M. H. – De Pelsmacker, P. – Geuens, M. (2009) Relationship quality and the theory of planned behavior models of behavioral intentions and purchase behavior. *Journal of Business Research*, Vol. 62 (1), 82-92.
- de Leeuw, E. – Collins, M. (1997) Data collection methods and survey quality: an overview. In: *Survey Measurement and Process Quality*, ed. by L. Lyberg – P. Biemer – M. Collins – E. de Leeuw – C. Dippo – N. Schwarz – D. Trewin, 199-220. New York, NY: Wiley.

- Deci, E. – Ryan, R. M. (2000) The "What" and "Why" of Goal Pursuits: Human Needs and the Self-Determination of Behavior. *Psychological Inquiry*, Vol. 11 (4), 227-268.
- Demski, R. M. – McGlynn, R. P. (1999) Fear or Moral Indignation? Predicting Attitudes Toward Parolees. *Journal of Applied Social Psychology*, Vol. 29 (10), 2024-2058.
- Diamantopoulos, A. – Winklhofer, H. M. (2001) Index Construction with Formative Indicators: An Alternative to Scale Development. *Journal of Marketing Research*, Vol. 38 (2), 269-277.
- Doll, J. – Ajzen, I. (1992) Accessibility and Stability of Predictors in the Theory of Planned Behavior. *Journal of Personality & Social Psychology*, Vol. 63 (5), 754-765.
- Eagly, A. H. – Chaiken, S. (1998) Attitude Structure and Function. In: *The Handbook of Social Psychology*, ed. by D. T. Gilbert – S. T. Fiske – G. Lindzey, 269-322. Boston, MA: McGraw-Hill.
- Fazio, R. H. – Olson, M. A. (2003) Attitudes: Foundations, Functions, and Consequences. In: *The SAGE handbook of social psychology*, ed. by M. A. Hogg – J. Cooper, 139-160. London: Sage Publications.
- Festinger, L. (1957) *A Theory of cognitive Dissonance*. Stanford University Press: Stanford, CA.
- Fetscherin, M. – Lattermann, C. (2008) User Acceptance of Virtual Worlds. *Journal of Electronic Commerce Research*, Vol. 9 (3), 231-242.
- Finney, S. J. – DiStefano, C. (2006) Nonnormal and Categorical Data in Structural Equation Modeling. In: *Structural equation modeling: a second course*, ed. by G. R. Hancock – R. O. Mueller, 269-314. Greenwich, CT: IAP.
- Fishbein, M. (1979) A Theory of Reasoned Action: Some Applications and Implications. In: *Nebraska Symposium on Motivation, Belief, and Attitude, and Values*, ed. by M. M. Page, 65-116. Lincoln, NE: University of Nebraska Press.
- Fishbein, M. – Ajzen, I. (1975) *Belief, Attitude, Intention and Behavior: An Introduction to Theory and Research*. Addison-Wesley: Reading, MA.
- Fishbein, M. – Ajzen, I. (2010) *Predicting and changing behavior: the reasoned action approach*. Psychology Press: New York, NY.

- Fornell, C. – Bookstein, F. L. (1982) Two structural equation models: LISREL and PLS applied to consumer exit-voice theory. *Journal of Marketing Research*, Vol. 19 (4), 440-452.
- Fornell, C. – Larcker, D. F. (1981) Evaluating structural equation models with unobservable variables and measurement error. *Journal of Marketing Research*, Vol. 18 (1), 39-50.
- Fuller, M. A. (2007) Diffusion of Virtual Innovation. *Database for Advances in Information Systems*, Vol. 38 (4), 40-44.
- Gagné, M. – Deci, E. L. (2005) Self-determination theory and work motivation. *Journal of Organizational Behavior*, Vol. 26 (4), 331-362.
- Gagne, C. – Godin, G. (2007) Does the easy-difficult item measure attitude or perceived behavioural control? *British Journal of Health Psychology*, Vol. 12 (4), 543-557.
- Godin, G. – Gagné, C. – Sheeran, P. (2004) Does perceived behavioural control mediate the relationship between power beliefs and intention? *British Journal of Health Psychology*, Vol. 9 (4), 557-568.
- Goel, L. – Johnson, N. A. – Junglas, I. – Ives, B. (2011) From Space to Place: Predicting Users' Intentions to Return to Virtual Worlds. *MIS Quarterly*, Vol. 35 (3), 749-771.
- Goel, L. – Johnson, N. – Junglas, I. – Ives, B. (2013) Predicting users' return to virtual worlds: a social perspective. *Information Systems Journal*, Vol. 23 (1), 35-63.
- Goles, T. – Hirschheim, R. (2000) The paradigm is dead, the paradigm is dead ... long live the paradigm: The legacy of Burrell and Morgan. *Omega*, Vol. 28 (3), 249-268.
- Goodhue, D. L. (1995) Understanding user evaluations of information systems. *Management Science*, Vol. 41 (12), 1827-1844.
- Goodhue, D. L. – Thompson, R. L. (1995) Task-technology fit and individual performance. *MIS Quarterly*, Vol. 19 (2), 213-236.
- Grewal, R. – Cote, J. A. – Baumgartner, H. (2004) Multicollinearity and Measurement Error in Structural Equation Models: Implications for Theory Testing. *Marketing Science*, Vol. 23 (4), 519-529.

- Grover, V. – Lee, C. C. – Durand, D. (1993) Analyzing methodological rigor of MIS survey research from 1980–1989. *Information & Management*, Vol. 24 (6), 305-317.
- Gruen, T. W. – Osmonbekov, T. – Czaplewski, A.,J. (2006) eWOM: The impact of customer-to-customer online know-how exchange on customer value and loyalty. *Journal of Business Research*, Vol. 59 (4), 449-456.
- Gu, J. – Fan, L. – Suh, Y. H. – Lee, S. (2010) Comparing Utilitarian and Hedonic Usefulness to User Intention in Multipurpose Information Systems. *CyberPsychology, Behavior & Social Networking*, Vol. 13 (3), 287-297.
- Habbo Hotel (2008) *Global Habbo Youth Survey*. 15/30 Research: Helsinki.
- Hair, J. F. – Sarstedt, M. – Ringle, C. M. – Mena, J. A. (2012) An assessment of the use of partial least squares structural equation modeling in marketing research. *Journal of the Academy of Marketing Science*, Vol. 40 (3), 414-433.
- Harter, S. (1981) A new self-report scale of intrinsic versus extrinsic orientation in the classroom: Motivational and informational components.. *Developmental psychology*, Vol. 17 (3), 300-312.
- Heeks, R. (2010) Understanding "Gold Farming" and Real-Money Trading as the Intersection of Real and Virtual Economies. *Journal of Virtual Worlds Research*, Vol. 2 (4), 1-27. <<http://journals.tdl.org/jvwr/index.php/jvwr/article/view/868/633>>, retrieved 6/5, 2013.
- Hirschheim, R. – Klein, H. K. (1989) Four Paradigms of Information Systems Development. *Communications of the ACM*, Vol. 32 (10), 1199-1216.
- Holsapple, C. W. (2007) User Acceptance of Virtual Worlds: The Hedonic Framework. *Database for Advances in Information Systems*, Vol. 38 (4), 86-89.
- Hong, S. – Tam, K. Y. (2006) Understanding the Adoption of Multipurpose Information Appliances: The Case of Mobile Data Services. *Information Systems Research*, Vol. 17 (2), 162-179.
- Hong, S. – Thong, J. Y. L. – Tam, K. Y. (2006) Understanding continued information technology usage behavior: A comparison of three models in the context of mobile internet. *Decision Support Systems*, Vol. 42 (3), 1819-1834.

- Hoogland, J. J. – Boomsma, A. (1998) Robustness Studies in Covariance Structure Modeling. *Sociological Methods & Research*, Vol. 26 (3), 329-367.
- Hsiao, C. – Chiou, J. (2012a) The effects of a player's network centrality on resource accessibility, game enjoyment, and continuance intention: A study on online gaming communities. *Electronic Commerce Research and Applications*, Vol. 11 (1), 75-84.
- Hsiao, C. – Chiou, J. (2012b) The impact of online community position on online game continuance intention: Do game knowledge and community size matter? *Information & Management*, Vol. 49 (6), 292-300.
- Hsieh, J. J. P. – Rai, A. – Keil, M. (2008) Understanding Digital Inequality: Comparing Continued use Behavioral Models of the Socio-Economically Advantaged and Disadvantaged. *MIS Quarterly*, Vol. 32 (1), 97-126.
- Hsu, M. – Chiu, C. (2004) Internet self-efficacy and electronic service acceptance. *Decision Support Systems*, Vol. 38 (3), 369-381.
- Hu, L. – Bentler, P. M. – Kano, Y. (1992) Can Test Statistics in Covariance Structure Analysis Be Trusted? *Psychological Bulletin*, Vol. 112 (2), 351-362.
- Hu, L. – Bentler, P. M. (1998) Fit Indices in Covariance Structure Modeling: Sensitivity to Underparameterized Model Misspecification. *Psychological Methods*, Vol. 3 (4), 424-453.
- Hu, L. – Bentler, P. M. (1999) Cutoff Criteria for Fit Indexes in Covariance Structure Analysis: Conventional Criteria Versus New Alternatives. *Structural Equation Modeling*, Vol. 6 (1), 1-55.
- Hua, G. – Haughton, D. (2009) Virtual worlds adoption: a research framework and empirical study. *Online Information Review*, Vol. 33 (5), 889-900.
- Huang, L. – Hsieh, Y. (2011) Predicting online game loyalty based on need gratification and experiential motives. *Internet Research*, Vol. 21 (5), 581-598.
- Hunt, S. D. (1990) Truth in Marketing Theory and Research. *Journal of Marketing*, Vol. 54 (3), 1-15.
- Hunt, S. D. (1991) Positivism and Paradigm Dominance in Consumer Research: Toward Critical Pluralism and Rapprochement. *Journal of Consumer Research*, Vol. 18 (1), 32-44.

- Iivari, J. – Hirschheim, R. – Klein, K. J. (1998) A paradigmatic analysis contrasting information systems development approaches and methodologies. *Information Systems Research*, Vol. 9 (2), 164-193.
- Ijsselsteijn, W. A. (2005) Towards a neuropsychological basis of presence. *Annual Review of Cybertherapy and Telemedicine*, Vol. 3 (1), 25-30.
- Jarvis, C. B. – MacKenzie, S. B. – Podsakoff, P. M. (2003) A Critical Review of Construct Indicators and Measurement Model Misspecification in Marketing and Consumer Research. *Journal of Consumer Research*, Vol. 30 (2), 199-218.
- Jasperson, J. S. – Carter, P. E. – Zmud, R. W. (2005) A Comprehensive Conceptualization of Post-Adoptive Behaviors Associated with Information Technology Enabled Work Systems. *MIS Quarterly*, Vol. 29 (3), 525-557.
- Jenkins, A. M. (1985) Research Methodologies and MIS Research. In: *Research Methods in Information Systems*, ed. by E. Mumford – R. Hirschheim – G. Fitzgerald – A. T. Wood-Harper, 103-117. Amsterdam: North-Holland.
- Jung, Y. (2011) Understanding the Role of Sense of Presence and Perceived Autonomy in Users' Continued Use of Social Virtual Worlds. *Journal of Computer-Mediated Communication*, Vol. 16 (4), 492-510.
- Jung, Y. – Kang, H. (2010) User goals in social virtual worlds: A means-end chain approach. *Computers in Human Behavior*, Vol. 26 (2), 218-225.
- Jöreskog, K. G. – Sörbom, D. (1993) *LISREL 8: Structural equation modeling with the SIMPLIS command language*. Scientific Software International: Chicago, IL.
- Karahanna, E. – Straub, D. W. – Chervany, N. L. (1999) Information Technology Adoption Across Time: A Cross-sectional Comparison of Pre-adoption and Post-adoption Beliefs. *MIS Quarterly*, Vol. 23 (2), 183-213.
- Karjaluoto, H. – Leppäniemi, M. (2013) Social Identity for Teenagers: Understanding Behavioral Intention to Participate in Virtual World Environment. *Journal of Theoretical and Applied Electronic Commerce Research*, Vol. 8 (1), 1-16.
- Katz, D. (1960) The Functional Approach to the Study of Attitudes. *The Public Opinion Quarterly*, Vol. 24 (2), 163-204.

- Kim, S. S. – Malhotra, N. K. (2005) Two Competing Perspectives on Automatic Use: A Theoretical and Empirical Comparison. *Information Systems Research; Linthicum*, Vol. 16 (4), 418-432.
- Kim, S. S. – Son, J. (2009) Out of Dedication or Constraint? A Dual Model of Post-Adoption Phenomena and Its Empirical Test in the Context of Online Service. *MIS Quarterly*, Vol. 33 (1), 49-70.
- Klein, H. K. (1999) A Set of Principles for Conducting and Evaluating Interpretive Field Studies in Information Systems. *MIS Quarterly*, Vol. 23 (1), 67-93.
- Kohler, T. – Füller, J. – Matzler, K. – Stieger, D. (2011) Co-Creation in Virtual Worlds: The Design of the User Experience. *MIS Quarterly*, Vol. 35 (3), 773-788.
- Kuhn, T. S. (1962) *The structure of scientific revolutions*. University of Chicago Press: Chicago, IL.
- kZero (2011) Virtual Worlds/MMOs: Industry and User Data. <<http://www.kzero.co.uk/blog/?p=4576>>, retrieved 9/2, 2011.
- kZero (2012) Latest News. <<http://www.kzero.co.uk/blog/>>, retrieved 12/12, 2012.
- Latané, B. (1981) The psychology of social impact. *American Psychologist*, Vol. 36 (4), 343-356.
- Lee, R. M. – Robbins, S. B. (1995) Measuring belongingness: The social connectedness and the social assurance scales. *Journal of Counseling Psychology*, Vol. 42 (2), 232-241.
- Lee, R. M. – Robbins, S. B. (1998) The relationship between social connectedness and anxiety, self-esteem, and social identity. *Journal of Counseling Psychology*, Vol. 45 (3), 338-345.
- Lee, M. – Tsai, T. (2010) What Drives People to Continue to Play Online Games? An Extension of Technology Model and Theory of Planned Behavior. *International Journal of Human - Computer Interaction*, Vol. 26 (6), 601-620.
- Lehdonvirta, V. (2009) Virtual items sales as a revenue model: identifying attributes that drive purchase decisions. *Electronic Commerce Research*, Vol. 9 (1-2), 97-113.

- Liang, H. – Saraf, N. – Hu, Q. – Xue, Y. (2007) Assimilation of Enterprise Systems: The Effect of Institutional Pressures and the Mediating Role of Top Management. *MIS Quarterly*, Vol. 31 (1), 59-87.
- Limayem, M. – Hirt, S. G. – Cheung, C. M. K. (2007) How Habit Limits the Predictive Power of Intention: The Case of Information Systems Continuance. *MIS Quarterly*, Vol. 31 (4), 705-738.
- Lombard, M. – Ditton, T. (1997) At the heart of it all: The concept of presence. *Journal of Computer-Mediated Communication*, Vol. 3 (2), <<http://jcmc.indiana.edu/vol3/issue2/lombard.html>>, retrieved 4/26, 2013.
- Lou, H. – Luo, W. – Strong, D. (2000) Perceived critical mass effect on groupware acceptance. *European Journal of Information Systems*, Vol. 9 (2), 91-103.
- Lu, H. – Wang, S. (2008) The role of Internet addiction in online game loyalty: an exploratory study. *Internet Research*, Vol. 18 (5), 499-519.
- MacKenzie, S. B. – Podsakoff, P. M. (2012) Common Method Bias in Marketing: Causes, Mechanisms, and Procedural Remedies. *Journal of Retailing*, Vol. 88 (4), 542-555.
- Matei, S. – Ball-Rokeach, S. (2001) Real and Virtual Social Ties: Connections in the Everyday Lives of Seven Ethnic Neighborhoods. *American Behavioral Scientist*, Vol. 45 (3), 550-564.
- McDonald, R. P. – Ho, M. R. (2002) Principles and practice in reporting structural equation analyses. *Psychological methods*, Vol. 7 (1), 64-82.
- Mennecke, B. E. – McNeil, D. – Roche, E. M. – Bray, D. A. – Townsend, A. M. – Lester, J. (2008) Second Life and Other Virtual Worlds: A Roadmap for Research. *Communications of AIS*, Vol. 2008 (22), 371-388.
- Merikivi, J. (2009) What Habbo Goers Do in Practice? Decomposing Attitudinal Beliefs. *17th European Conference on Information Systems*, Verona, Italy, 8.-10.6.2009.
- Merikivi, J. – Mäntymäki, M. (2009) Explaining the Continuous Use of Social Virtual Worlds: An Applied Theory of Planned Behavior Approach. *Proceedings of the 42nd Annual Hawaii International Conference on System Sciences*, Hawaii, 5.-8.1.2009.

- Merikivi, J. – Verhagen, T. – Feldberg, F. (2012) Having belief(s) in social virtual worlds: A decomposed approach. *New Media & Society*, <<http://nms.sagepub.com/content/early/2012/11/26/1461444812466719.full.pdf+html>>, retrieved 4/26, 2013.
- Meyer, D. (2012) Habbo plans post-scandal reinvention, but that means cutting jobs. <<http://gigaom.com/europe/habbo-plans-post-scandal-reinvention-but-that-means-cutting-jobs/>>, retrieved 10/30, 2012.
- Mingers, J. (2001) Combining IS research methods: Towards a pluralist methodology. *Information Systems Research*, Vol. 12 (3), 240-259.
- Moore, G. C. – Benbasat, I. (1991) Development of an Instrument to Measure the Perceptions of Adopting an Information Technology Innovation. *Information Systems Research*, Vol. 2 (3), 191-222.
- Mäntymäki, M. (2011) *Continuous use and purchasing behaviour in social virtual worlds*. (Doctoral dissertation). Turku School of Economics: Turku, Finland.
- Mäntymäki, M. – Salo, J. (2011) Teenagers in social virtual worlds: Continuous use and purchasing behavior in Habbo Hotel. *Computers in Human Behavior*, Vol. 27 (6), 2088-2097.
- Mäntymäki, M. – Merikivi, J. – Verhagen, T. – Feldberg, F. – Rajala, R. (in review) Still there? Understanding the continued use of virtual worlds. Unpublished manuscript.
- Nevo, S. – Nevo, D. – Kim, H. (2012) From recreational applications to workplace technologies: an empirical study of cross-context IS continuance in the case of virtual worlds. *Journal of Information Technology*, Vol. 27 (1), 74-86.
- Novak, T. P. (2000) Measuring the customer experience in online environments: A structural modeling approach. *Marketing Science*, Vol. 19 (1), 22-42.
- Oliver, R. L. (1977) Effect of Expectation and Disconfirmation on Postexposure Product Evaluations - An Alternative Interpretation. *Journal of Applied Psychology*, Vol. 62 (4), 480-486.
- Oliver, R. L. (1980) A Cognitive Model of the Antecedents and Consequences of Satisfaction Decisions. *Journal of Marketing Research*, Vol. 17 (4), 460-469.

- Orlikowski, W. J. – Baroudi, J. J. (1991) Studying Information Technology in Organizations: Research Approaches and Assumptions. *Information Systems Research*, Vol. 2 (1), 1-28.
- Orlikowski, W. J. – Robey, D. (1991) Information Technology and the Structuring of Organizations. *Information Systems Research*, Vol. 2 (2), 143-169.
- Ouellette, J. A. – Wood, W. (1998) Habit and intention in everyday life: The multiple processes by which past behavior predicts future behavior. *Psychological bulletin*, Vol. 214 (1), 54-74.
- Pavlou, P. A. – Fygenson, M. (2006) Understanding and Predicting Electronic Commerce Adoption: An Extension of the Theory of Planned Behavior. *MIS Quarterly*, Vol. 30 (1), 115-143.
- Ping, R. A. J. (2004) On assuring valid measures for theoretical models using survey data. *Journal of Business Research*, Vol. 57 (2), 125-141.
- Pinsonneault, A. – Kraemer, K. L. (1993) Survey research methodology in management information systems: An assessment. *Journal of Management Information Systems*, Vol. 10 (2), 75-105.
- Podsakoff, P. M. – MacKenzie, S. B. – Lee, J. – Podsakoff, N. P. (2003) Common Method Biases in Behavioral Research: A Critical Review of the Literature and Recommended Remedies. *Journal of Applied Psychology*, Vol. 88 (5), 879-903.
- Podsakoff, P. M. – Organ, D. W. (1986) Self-Reports in Organizational Research: Problems and Prospects. *Journal of Management*, Vol. 12 (4), 531-545.
- Premkumar, G. – Ramamurthy, K. – Liu, H. (2008) Internet messaging: An examination of the impact of attitudinal, normative, and control belief systems. *Information & Management*, Vol. 45 (7), 451-457.
- Prensky, M. (2001) Digital Natives, Digital Immigrants Part 1. *On the Horizon*, Vol. 9 (5), 1-6.
- Rheingold, H. (2000) *The Virtual Community: Homesteading on the Electronic Frontier*. MIT Press: Cambridge, MA.
- Richard, M. – Chebat, J. – Yang, Z. – Putrevu, S. (2010) A proposed model of online consumer behavior: Assessing the role of gender. *Journal of Business Research*, Vol. 63 (9), 926-934.

- Riedl, C. – Köbler, F. – Goswami, S. – Krcmar, H. (2013) Tweeting to Feel Connected: A Model for Social Connectedness in Online Social Networks. *International Journal of Human-Computer Interaction*. <<http://dx.doi.org/10.1080/10447318.2013.768137>>, retrieved 5/25, 2013.
- Ringle, C. M. – Wende, S. – Will, S. (2005) SmartPLS 2.0 (M3) Beta. <<http://www.smartpls.de>>, retrieved 8/9, 2010.
- Rogers, E. M. (2003) *Diffusion of Innovations*. Free Press: New York, NY.
- Ruvio, A. (2008) Consumers' need for uniqueness: short-form scale development and cross-cultural validation. *International Marketing Review*, Vol. 25 (1), 33-53.
- Ryan, R. M. – Deci, E. L. (2000a) Intrinsic and Extrinsic Motivations: Classic Definitions and New Directions. *Contemporary educational psychology*, Vol. 25 (1), 54-67.
- Ryan, R. M. – Deci, E. L. (2000b) Self-Determination Theory and the Facilitation of Intrinsic Motivation, Social Development, and Well-Being. *American Psychologist*, Vol. 55 (1), 68-78.
- Ryan, R. M. – Deci, E. L. (2002) Introduction. In: *Handbook of Self-Determination Research*, ed. by E. L. Deci – R. M. Ryan, 3-33. Rochester, NY: University of Rochester Press.
- Schultz, M. – Hatch, M. J. (1996) Living with multiple paradigms: The case of paradigm interplay in organizational culture studies. *Academy of Management Review*, Vol. 21 (2), 529-557.
- Schumacker, R. E. – Lomax, R. G. (2004) *A beginner's guide to structural equation modeling*. Lawrence Erlbaum: Mahwah, NJ.
- Schwarz, A. – Schwarz, C. – Jung, Y. – Pérez-Mira, B. – Wiley-Patton, S. (2012) Towards an understanding of assimilation in virtual worlds: the 3C approach. *European Journal of Information Systems*, Vol. 21 (3), 303-320.
- Seegert, A. (2009) 'Doing there' vs. 'being there': performing presence in interactive fiction. *Journal of Gaming and Virtual Worlds*, Vol. 1 (1), 23-37.

- Sheehan, K. B. (2001) E-mail Survey Response Rates. *Journal of Computer-Mediated Communication*, Vol. 6 (2), May 9, 2001, <<http://jcmc.indiana.edu/vol6/issue2/sheehan.html>>, retrieved 4/26, 2013.
- Sheppard, B. H. – Hartwick, J. – Warshaw, P. R. (1988) The Theory Of Reasoned Action: A Meta-Analysis Of Past Rese. *Journal of Consumer Research*, Vol. 15 (3), 325-343.
- Shimp, T. A. – Kavas, A. (1984) The Theory of Reasoned Action Applied to Coupon Usage. *Journal of Consumer Research*, Vol. 11 (3), 795-809.
- Shin, D. H. (2009) The Evaluation of User Experience of the Virtual World in Relation to Extrinsic and Intrinsic Motivation. *International Journal of Human-Computer Interaction*, Vol. 25 (6), 530-553.
- Short, J. (1976) *The social psychology of telecommunications*. John Wiley & Sons: London.
- Siponen, M. – Vance, A. (2010) Neutralization: New Insights Into the Problem of Employee Information Systems Security Policy Violations. *MIS Quarterly*, Vol. 34 (3), 487-502.
- Snyder, C. R. – Fromkin, H. L. (1977) Abnormality as a positive characteristic: The development and validation of a scale measuring need for uniqueness. *Journal of Abnormal Psychology*, Vol. 86 (5), 518-527.
- Snyder, M. – DeBono, K. G. (1989) Understanding the Functions of Attitudes: Lessons From Personality and Social Behavior. In: *Attitude structure and function*, ed. by A. R. Pratkanis – S. J. Breckler – A. G. Greenwald, 339-360. Hillsdale, NJ: Erlbaum.
- Sosik, J. J. – Kahai, S. S. – Piovoso, M. J. (2009) Silver Bullet or Voodoo Statistics? A Primer for Using the Partial Least Squares Data Analytic Technique in Group and Organization Research. *Group & Organization Management*, Vol. 34 (1), 5-36.
- Spero, I. (2004) Agents of change: how young consumers are changing the world of marketing. *Qualitative Market Research: An International Journal*, Vol. 7 (2), 153-159.
- Stahl, B. C. (2008) *Information Systems: Critical Perspectives*. Routledge: London.
- Steiger, J. H. (2007) Understanding the limitations of global fit assessment in structural equation modeling. *Personality and Individual Differences*, Vol. 42 (5), 893-898.

- Steinkuehler, C. A. – Williams, D. (2006) Where Everybody Knows Your (Screen) Name: Online Games as "Third Places". *Journal of Computer-Mediated Communication*, Vol. 11 (4), 885-909.
- Stutzman, T. M. – Green, S. B. (1982) Factors affecting energy consumption: Two field tests of the Fishbein-Ajzen model. *The Journal of Social Psychology*, Vol. 117 (2), 183-201.
- Suh, K. – Kim, H. – Suh, E. K. (2011) What If Your Avatar Looks Like You? Dual-Congruity Perspectives for Aavatar Use. *MIS Quarterly*, Vol. 35 (3), 711-729.
- Sulake Corporation (2009) Habbo Hotel and Facebook are now connected. <http://www.sulake.com/press/releases/2009-12-22-Habbo_Hotel_and_Facebook_are_now_connected_.html>, retrieved 01/01, 2012.
- Sulake Corporation (2012) Habbo – Where else? <<http://www.sulake.com/habbo/?navi=2>>, retrieved 06/18, 2012.
- Szajna, B. (1996) Empirical evaluation of the revised technology acceptance model. *Management Science*, Vol. 42 (1), 85-92.
- Tabachnick, B. G. – Fidell, L. S. (2007) *Using Multivariate Statistics*. Pearson / Allyn and Bacon: Boston, MA.
- Takahashi, D. (2010) Teen virtual world Gaia online lays off 15 to 20 staffers. <<http://venturebeat.com/2010/11/23/teens-virtual-world-gaia-online-lays-off-15-to-20-staffers/>>, retrieved 10/30, 2012.
- Takahashi, D. (2011) Virtual world Habbo hits more than 200M registered users. <<http://venturebeat.com/2011/02/03/virtual-world-habbo-hits-more-than-200m-registered-users/>>, retrieved 10/23, 2012.
- Tan, W. – Tan, C. – Teo, H. (2012) Conveying information effectively in a virtual world. *Journal of the American Society for Information Science and Technology*, Vol. 63 (6), 1198-1212.
- Taylor, S. – Todd, P. (1995a) Decomposition and crossover effects in the theory of planned behavior: A study of consumer adoption intentions. *International Journal of Research in Marketing*, Vol. 12 (2), 137-155.
- Taylor, S. – Todd, P. (1995b) Understanding information technology usage: A test of competing models. *Information Systems Research*, Vol. 6 (2), 144-176.

- Taylor, T. L. (2006) *Play Between Worlds: Exploring Online Game Culture*. MIT Press: Cambridge, MA.
- Teng, C. (2010) Customization, immersion satisfaction, and online gamer loyalty. *Computers in Human Behavior*, Vol. 26 (6), 1547-1554.
- Teng, C. – Chen, M. – Chen, Y. – Li, Y. (2012) Loyalty Due to Others: The Relationships Among Challenge, Interdependence, and Online Gamer Loyalty. *Journal of Computer-Mediated Communication*, Vol. 17 (4), 489-500.
- Thompson, R. L. – Higgins, C. A. – Howell, J. M. (1991) Personal Computing: Toward a Conceptual Model of Utilization. *MIS Quarterly*, Vol. 15 (1), 125-143.
- Tian, K. T. (2001) Consumers' Need for Uniqueness: Scale Development and Validation. *Journal of Consumer Research*, Vol. 28 (1), 50-66.
- Tikkanen, H. – Hietanen, J. – Henttonen, T. – Rokka, J. (2009) Exploring virtual worlds: success factors in virtual world marketing. *Management Decision*, Vol. 47 (8), 1357-1381.
- Triandis, H. C. (1977) *Interpersonal Behaviour*. Brooks/Cole: Monterey, CA.
- Triandis, H. C. (1979) Values, Attitudes, and Interpersonal Behavior. In: *Nebraska Symposium on Motivation, Belief, and Attitude, and Values*, ed. by M. M. Page, 195-259. Lincoln, NE: University of Nebraska Press.
- Triandis, H. C. (1989) The Self and Social Behavior in Differing Cultural Contexts. *Psychological Review*, Vol. 96 (3), 506-520.
- Valente, T. W. (1995) *Network models of the diffusion of innovations*. Hampton Press: Cresskill, NJ.
- van der Heijden, H. (2003) Factors influencing the usage of websites: the case of a generic portal in The Netherlands. *Information & Management*, (6), 541-549.
- van Slyke, C. – Ilie, V. – Lou, H. – Stafford, T. (2007) Perceived critical mass and the adoption of a communication technology. *European Journal of Information Systems*, Vol. 16 (3), 270-283.
- Vasalou, A. – Joinson, A. – Bänziger, T. – Goldie, P. – Pitt, J. (2008) Avatars in social media: Balancing accuracy, playfulness and embodied messages. *International Journal of Human-Computer Studies*, Vol. 66 (11), 801-811.

- Venkatesh, V. (2003) User Acceptance of Information Technology: Toward a Unified View. *MIS Quarterly*, Vol. 27 (3), 425-478.
- Venkatesh, V. – Bala, H. (2008) Technology Acceptance Model 3 and a Research Agenda on Interventions. *Decision Sciences*, Vol. 39 (2), 273-315.
- Venkatesh, V. – Brown, S. A. (2001) A Longitudinal Investigation of Personal Computers in Homes: Adoption Determinants and Emerging Challenges. *MIS Quarterly*, Vol. 25 (1), 71-102.
- Venkatesh, V. – Davis, F. D. (2000) A Theoretical Extension of the Technology Acceptance Model: Four Longitudinal Field Studies. *Management Science*, Vol. 46 (2), 186-204.
- Verhagen, T. – Feldberg, F. – van den Hooff, B. – Meents, S. (2009) Understanding Virtual Worlds Usage: A Multipurpose Model and Empirical Testing. *17th European Conference on Information Systems*, Verona, Italy, 8.-10.6.2009.
- Verhagen, T. – Feldberg, F. – van den Hooff, B. – Meents, S. – Merikivi, J. (2011) Satisfaction with virtual worlds: An integrated model of experiential value. *Information & Management*, Vol. 48 (6), 201-207.
- Verhagen, T. – Feldberg, F. – van den Hooff, B. – Meents, S. – Merikivi, J. (2012) Understanding users' motivations to engage in virtual worlds: A multipurpose model and empirical testing. *Computers in Human Behavior*, Vol. 28 (2), 484-495.
- Vijayarathy, L. R. (2004) Predicting consumer intentions to use on-line shopping: the case for an augmented technology acceptance model. *Information & Management*, Vol. 41 (6), 747-762.
- Walsham, G. (1995) Interpretive case studies in IS research: Nature and method. *European Journal of Information Systems*, Vol. 4 (2), 74-81.
- Wasko, M. – Teigland, R. – Leidner, D. – Järvenpää, S. (2011) Stepping into the Internet: New Ventures in Virtual Worlds. *MIS Quarterly*, Vol. 35 (3), 645-652.
- Webster, J. – Watson, R. T. (2002) Analyzing the Past to Prepare for the Future: Writing a Literature Review. *MIS Quarterly*, Vol. 26 (2), 13-23.
- Wheaton, B. – Muthen, B. – Alwin, D. F. – Summers, G. F. (1977) Assessing Reliability and Stability in Panel Models. *Sociological Methodology*, Vol. 8 (1), 84-136.

- Williams, M. D. – Dwivedi, Y. K. – Banita, L. – Schwarz, A. (2009) Contemporary trends and issues in IT adoption and diffusion research. *Journal of Information Technology*, Vol. 24 (1), 1-10.
- Wilson, T. D. – Lindsey, S. – Schooler, T. Y. (2000) A Model of Dual Attitudes. *Psychological review*, Vol. 107 (1), 101-126.
- Woszczynski, A. B. – Roth, P. L. – Segars, A. H. (2002) Exploring the theoretical foundations of playfulness in computer interactions. *Computers in Human Behavior*, Vol. 18 (4), 369-388.
- Wright, K. B. (2005) Researching Internet-Based Populations. *Journal of Computer-Mediated Communication*, Vol. 10 (3), article 11.
- Yang, H. – Wu, C. – Wang, K. (2009) An empirical analysis of online game service satisfaction and loyalty. *Expert Systems with Applications*, Vol. 36 (2), 1816-1825.
- Yoo, Y. – Alavi, M. (2001) Media and group cohesion: Relative influences on social presence, task participation, and group consensus. *MIS Quarterly*, Vol. 25 (3), 371-390.
- Youniss, J. – Smollar, J. (1985) The individual and relations. In: *Adolescent relations with mothers, fathers, and friends*, ed. by J. Youniss – J. Smollar, 160-176. Chicago, IL: The University of Chicago Press.
- Zhou, Z. – Fang, Y. – Vogel, D. R. – Jin, X. – Zhang, X. (2012) Attracted to or Locked In? Predicting Continuance Intention in Social Virtual World Services. *Journal of Management Information Systems*, Vol. 29 (1), 273-306.

APPENDICES

Appendix 1 Overview of IS adoption theories and models

Theory/model	Overview of the theory	Explicandum(s)	Originating author(s)
Innovation diffusion theory (IDT)	IDT, originating in sociology, seeks to explain the diffusion of innovation through certain channels over time and within a particular social systems	Adoption behavior	Rogers (2003)
Theory of reasoned action (TRA)	Behavior is driven by behavioral intentions, a function of attitude towards the behavior and subjective norm	Behavioral intention and behavior	Ajzen and Fishbein (1973); Fishbein and Ajzen (1975)
Technology acceptance model (TAM)	Employing perceived ease of use and usefulness, the theory seeks to explain user acceptance of a new IT application.	IT adoption intention and behavior	Davis (1989); Davis et al. (1989)
Theory of planned behavior (TPB)	Added with perceived behavioral control, behavioral intention is determined by attitude towards the behavior and subjective norm	Behavioral intention and behavior	Ajzen (1991)
Combined TAM and TPB (C-TAM-TPB)	Combines TPB and TAM	IT adoption intention and behavior	Taylor and Todd (1995b)
Decomposed theory of planned behavior (DTPB)	Building on TPB, DTPB disaggregates the attitudinal, normative, and control beliefs	IT adoption intention and behavior	Taylor and Todd (1995b)
TAM2	Extends TAM by including social influences and instrumental processes	IT adoption intention and behavior	Venkatesh and Davis (2000)
Unified theory of acceptance and use of technology (UTAUT)	Holds that performance and effort expectancy, social influence and facilitating conditions each influence use behavior but are moderated with gender, age, experience and voluntariness	IT adoption intention and behavior	Venkatesh et al. (2003)
TAM3	Extends TAM2 by decomposing perceived ease of use	IT adoption intention and behavior	Venkatesh and Bala (2008)
Theory of interpersonal behavior (TIB)	Holds that habit, intentions and facilitating conditions determine behavior	Behavioral intention and behavior	Triandis (1977)
Model of PC utilization (MPCU)	Differentiates between perceptions of the actual use and the beliefs about future consequences from the IT use	computer adoption intention and behavior	Thompson et al. (1991)
Task-technology fit (TTF)	On an organizational level, IT is considered useful and adopted if its capabilities match the tasks that the user performs	Performance impacts and utilization	Goodhue (1995); Goodhue and Thompson (1995)
Expectation-disconfirmation	Focuses on how and why behavior changes over time by positing that expectations,	Satisfaction	Oliver (1977; 1980)

Theory/model	Overview of the theory	Explicandum(s)	Originating author(s)
theory (ECT)	confirmation, and performance influence satisfaction with a product or service		
IS continuance model	Combines TAM with ECT to predict use continuance	Satisfaction, continuance intention	Bhattacharjee (2001)

Appendix 2 Title page of the online questionnaire

20% valmiina(Sivu 1 / 5)

Tulosta



Aikomus jatkaa Habbon käyttöä

Tämän kysely on osa Habbon käyttöä tarkastelevaa tutkimusta. Vastauksesi käsitellään nimettömästi. Toivomme sinun vastaavan rehellisesti ja täsmällisesti. Emme tarjota palkintoa, mutta tarkoituksemme on ymmärtää Habbon käyttöä ja tukea toiveitasi tulevaisuudessa. Kyselyyn vastaaminen vie alle 25 minuuttia. Voit lopettaa kyselyyn vastaamisen milloin tahansa sulkeamalla sen, mikäli niin haluat. Muutoin paina "lähetä", kun olet täyttänyt kyselyn. Jos sinulla on kysyttävää voit joko tutustua sivustoihimme (www.nuorisotutkimusseura.fi, www.tucs.fi ja www.tse.fi) tai lähettää meille sähköpostia: [youth_survey\(at\)nuorisotutkimus.fi](mailto:youth_survey(at)nuorisotutkimus.fi).

Kiitoksia vaivannäöstäsi.

1. Sukupuoli

Tyttö Poika

2. Ikä

-Valitse-

3. Kuinka monta vuotta koulua olet käynyt?

(esim. vastaa 4, jos olet nyt 5:nnellä luokalla. Jos olet opiskellut osa-aikaisesti, muunna ko. aika täysiksi vuosiksi.

Huom. Tätä kysymystä koskevia vastauksia ei luovuteta Habbolle.

-Valitse-

4. Kenen kanssa asut?

-Valitse-

5. Mikä on talutesi tulotaso verrattuna muihin?

(Kuinka paljon rahaa perheellä, jossa asut, on verrattuna muihin perheisiin?)

Huom. Tätä kysymystä koskevia vastauksia ei luovuteta Habbolle.

Asteikolla 1-7, jossa 1= äärimmäisen alhainen ja 7= äärimmäisen korkea

1 2 3 4 5 6 7
 Äärimmäisen alhainen Äärimmäisen korkea

6. Missä maassa asut?

-Valitse-

7. Milloin liityit mukaan Habboon?

-Valitse-

Appendix 3 Scales and measures in English (and Finnish)

Constructs	Items (1=Strongly disagree; 7=Strongly agree)
Attitude	Extremely bad...good (Äärimmäisen huonoa/hyvää)
All things considered, using Habbo ¹ is... (Kaiken kaikkiaan, Habbon käyttäminen on...)	Extremely dissatisfying...satisfying (Äärimmäisen epätydyttävää/tydyttävää)
	Extremely displeasing...pleasing (Äärimmäisen epämiellyttävää/miellyttävää)
	Extremely terrible...delightful (Äärimmäisen kauheaa/ilahduttavaa)
	Extremely frustrating...easy; a great pleasure to use (Äärimmäisen turhauttavaa/helppoa, käyttäminen on suuri ilo)
Perceived usefulness	Allows me to express myself (Antaa minulle mahdollisuuden ilmaista itseäni)
Using Habbo... (Habbon käyttäminen...)	Comes in handy for my communication (On kätevää kun haluan pitää yhteyttä ihmisiin)
	Is a good way to spend free time (On hyvä tapa viettää vapaa-aikaa)
	Helps me to stay in close touch with my friends (Auttaa minua pysymään läheisessä yhteydessä kavereideni kanssa)
	Helps me to stay in close touch with people I know (Auttaa minua pysymään läheisessä yhteydessä tuttavieni kanssa)
	Helps me to make new friends more efficiently (Auttaa minua saamaan paremmin uusia ystäviä)
Perceived enjoyment	It is enjoyable to use Habbo (Habbon käyttäminen on nautittavaa)
	It is fun to use Habbo (Habbon käyttäminen on hauskaa)
	It is entertaining to use Habbo (Habbon käyttäminen on viihdyttävää)
	It is pleasant to use Habbo (Habbon käyttäminen on miellyttävää)
Status	Using Habbo improves my status among those who are richest and smartest (Habbon käyttäminen nostaa asemaani rikkaimpien ja fiksuimpien keskuudessa)
	Using Habbo improves my status among those who are the most meaningful to me (Habbon käyttäminen nostaa asemaani niiden keskuudessa, jotka merkitsevät minulle eniten)
Playfulness	Using Habbo increases my interest in exploring things (Habbon käyttäminen lisää mielenkiintoa asioiden tutkimiseen)
	Using Habbo arouses my imagination (Habbon käyttäminen saa mielikuvitukseni liikkeelle)
Uniqueness	I actively seek to develop my personal uniqueness by using special products or brands (Pyrin aktiivisesti kehittämään henkilökohtaista ainutlaatuisuuttani käyttämällä erikoisia tuotteita tai tuotemerkkejä)
	Having an eye for products that are interesting and unusual assist me in establishing a distinctive image (Se, että minulla on silmää mielenkiintoisille ja epätavallisille tuotteille, auttaa minua luomaan selvästi erottuvan imagon (tyylin))
	The products and the brand I like the best are the ones that express my individuality (Tuotteet ja tuotemerkit, joista pidän eniten, ovat ne, jotka ilmaisevat yksilöllisyyttäni)
	I am often on the lookout for new products or brands that will add to my personal uniqueness (Etsin usein uusia tuotteita tai tuotemerkkejä, jotka lisäävät henkilökohtaista ainutlaatuisuuttani)
Connectedness	I feel so distant from others in Habbo (Koen itseni kovin etäiseksi muista Habbossa)
	I have no feeling of togetherness with others in Habbo (Minulla ei ole minkäänlaista yhteydenkuuluvuuden tunnetta muita kohtaan Habbossa)
Subjective norm	People who influence me think I should use Habbo (Ihmiset joilla on vaikutusta minuun (joiden mielipidettä arvostan), ovat sitä mieltä, että minun pitäisi käyttää Habboa)
	Among my friends, using Habbo is widely accepted (Ystäväni keskuudessa Habbon käyttö vapaa-ajalla on laajasti hyväksyttyä)

Constructs	Items (1=Strongly disagree; 7=Strongly agree)
Interpersonal influence (social influence)	People who are important to me use Habbo (Minulle tärkeät ihmiset käyttävät Habboa)
	My family thinks I should use Habbo (Perheeni mielestä minun pitäisi käyttää Habboa)
	My relatives think I should use Habbo (Sukulaisteni mielestä minun pitäisi käyttää Habboa)
	My friends think I should use Habbo (Ystäväni mielestä minun pitäisi käyttää Habboa)
External influence (mass media)	I feel pressure from media and commercials to use Habbo (Koen median ja mainosten painostavan minua käyttämään Habboa)
	I feel encouraged by media and commercials to use Habbo (Koen median ja mainosten rohkaisevan minua käyttämään Habboa)
	I feel persuaded by media and commercials to use Habbo (Koen median ja mainosten taivuttelevan minua käyttämään Habboa)
Perceived critical mass	How many people about your age use Habbo? (Kuinka moni ikätovereistasi käyttää Habboa?)
	How many of your friends use Habbo? (Kuinka moni ystävästäsi käyttää Habboa?)
	How many people most meaningful to you use Habbo? (Kuinka moni ympärillä olevista ihmisistä käyttää Habboa?)
Perceived behavioral control	I have the resources, knowledge, and ability to use Habbo (Minulla on tarvittava tietämys, osaaminen ja resurssit käyttää Habboa)
	I can use Habbo (Osaan käyttää Habboa)
	I know how to use Habbo (Tiedän miten Habboa käytetään)
Perceived ease of use	Using Habbo it entirely within my control (Habbon käyttö on täysin minun hallinnassani)
	I find Habbo easy to use (Minusta Habboa on helppo käyttää)
	I find it easy to do what I intend to do in Habbo (Minusta Habbossa on helppo tehdä se mitä kulloinkin aion tehdä)
	Using Habbo does not require a lot of my mental effort (Habbon käyttäminen ei vaadi minulta suuria henkisiä ponnistuksia)
	Using Habbo to communicate with others is clear and understandable (Habbon käyttäminen kommunikoinnissa muiden kanssa on selkeää ja ymmärrettävää)
	Navigation through the menus and toolbars in Habbo is easy to do (Navigointi Habbon käyttöliittymässä on helppoa)
	It is easy to learn how to use all that is provided in Habbo (On helppoa oppia käyttämään kaikkea mitä Habbossa on tarjolla)
Self-efficacy	I feel comfortable using Habbo on my own (Habbon käyttäminen itsenäisesti (ilman, että tarvitsen kenenkään apua) on minusta vaivatonta)
	I can easily operate in Habbo on my own (Pystyn helposti toimimaan Habbossa itsenäisesti (ilman, että tarvitsen kenenkään apua))
	I feel comfortable using Habbo even if there is no one around me to tell how to use it (Habbon käyttäminen tuntuu minusta vaivattomalta, vaikka lähelläni ei olisi ketään joka kertoisi minulle mitä tehdä)
Social presence	There is a sense of human contact in Habbo (Habbossa on tunne inhimillisestä kontaktista (tuntuu että olen tekemisissä ihmisten, en koneiden kanssa))
	There is a sense of sociability in Habbo (users are companionable) (Habbossa on tunne seurallisuudesta (käyttäjät ovat toverillisia))
	There is a sense of human warmth in Habbo (Habbossa on tunne inhimillisestä lämmöstä)
Continual VW use intention	I intend to continue using Habbo during the next three months (Aion jatkaa Habbon käyttöä seuraavan kolmen kuukauden aikana)
	I will keep on using Habbo in the future (Tulen jatkamaan Habbon käyttöä tulevaisuu-

Constructs	Items (1=Strongly disagree; 7=Strongly agree)
	dezza)
	I intend to continue using Habbo frequently during the next three months (Aion jatkaa Habbon käyttöä säännöllisesti seuraavan kolmen kuukauden aikana)
	I intend to revisit Habbo shortly (Aion vieraillla Habbossa uudelleen piakkoin)
	I predict I will revisit Habbo in the short term (Ennakoin, että tulen vieraillemaan Habbossa lähitulevaisuudessa)

¹ At the time the survey was conducted, in 2008, Habbo Hotel was known as Habbo

Appendix 4 Convergent validity (article 2)

Construct	Composite reliability	Cronbach's alpha	AVE	Item	Loading
Enjoyment (ENJ)	0.953	0.952	0.723	ENJ1	0.909
				ENJ2	0.958
				ENJ3	0.933
Playfulness (PLA)	0.842	0.842	0.593	PLA1	0.869
				PLA2	0.837
Connectedness (CON)	0.841	0.839	0.592	CON1	0.813
				CON2	0.889
Uniqueness (UNI)	0.953	0.953	0.769	UNI1	0.907
				UNI2	0.923
				UNI3	0.902
				UNI4	0.921
Status (STA)	0.893	0.894	0.618	STA1	0.888
				STA2	0.909
Social presence (PRE)	0.859	0.859	0.601	PRE1	0.872
				PRE2	0.864
Attitude (ATT)	0.936	0.938	0.713	ATT1	0.915
				ATT2	0.906
				ATT3	0.910

Appendix 5 Convergent validity (article 3)

Construct	Composite reliability	Cronbach's alpha	AVE	Item	Loading
Attitude (ATT)	0.935	0.901	0.758	ATT1	0.861
				ATT2	0.854
				ATT3	0.896
				ATT4	0.926
Perceived usefulness (PU)	0.931	0.931	0.756	PU1	0.881
				PU2	0.866
				PU3	0.891

Construct	Composite reliability	Cronbach's alpha	AVE	Item	Loading
Enjoyment (ENJ)	0.905	0.944	0.715	PU4	0.878
				ENJ1	0.887
				ENJ2	0.927
				ENJ3	0.930
Subjective norm (SN)	0.871	0.870	0.675	SN1	0.837
				SN2	0.814
				SN3	0.845
External influence (EXT)	0.886	0.882	0.684	EXT1	0.865
				EXT2	0.886
				EXT3	0.794
Interpersonal influence (INT)	0.950	0.906	0.721	INT1	0.934
				INT2	0.780
				INT3	0.938
Social Presence (SP)	0.880	0.876	0.681	SP1	0.746
				SP2	0.898
				SP3	0.877
Perceived Behavioral Control (PBC)	0.923	0.913	0.751	PBC1	0.702
				PBC2	0.969
				PBC3	0.973
				PBC4	0.798
Self-efficacy (SE)	0.911	0.950	0.699	SE1	0.919
				SE2	0.940
				SE3	0.928
Perceived ease of use (PEOU)	0.908	0.910	0.697	PEOU1	0.857
				PEOU2	0.877
				PEOU3	0.902
Continual use intention (CUI)	0.917	0.906	0.702	CUI1	0.898
				CUI2	0.871
				CUI3	0.859

Appendix 6 Convergent validity (article 4)

Construct	Composite reliability	Cronbach's alpha	AVE	Item	Loading
Perceived usefulness (PU)	0.918	0.867	0.789	PU1	0.887
				PU2	0.884
				PU3	0.894
Perceived enjoyment (ENJ)	0.959	0.936	0.886	ENJ1	0.924
				ENJ2	0.950
				ENJ3	0.950
Social Influence (SI)	0.936	0.898	0.829	SI1	0.919
				SI2	0.930
				SI3	0.881
Perceived Critical Mass (PCM)	0.917	0.865	0.786	PCM1	0.886
				PCM2	0.906
				PCM3	0.867
Perceived Ease of Use (PEOU)	0.954	0.935	0.837	PEOU1	0.924
				PEOU2	0.939
				PEOU3	0.907
				PEOU4	0.889
Self-efficacy (SE)	0.961	0.938	0.890	SE1	0.939
				SE2	0.948
				SE3	0.944
Continual intention (INT)	0.957	0.933	0.882	INT1	0.927
				INT2	0.951
				INT3	0.939

Appendix 7 Discriminant validity (article 2)

Construct	ATT	ENJ	PLA	CON	STA	PRE	UNI
ATT	0.713						
ENJ	0.503	0.723					
PLA	0.393	0.637	0.593				
CON	0.002	0.010	0.002	0.592			
STA	0.154	0.206	0.416	0.098	0.618		
PRE	0.336	0.504	0.490	0.011	0.274	0.601	
UNI	0.077	0.103	0.205	0.061	0.249	0.158	0.769

Appendix 8 Discriminant validity (article 3)

Construct	ATT	CUI	ENJ	EXT	PBC	PEOU	INT	SE	SN	PU	SP
ATT	0.758										
CUI	0.285	0.697									
ENJ	0.469	0.517	0.715								
EXT	0.102	0.062	0.097	0.684							
PBC	0.062	0.181	0.173	0.001	0.751						
PEOU	0.204	0.343	0.353	0.029	0.448	0.699					
INT	0.143	0.149	0.194	0.353	0.009	0.053	0.702				
SE	0.040	0.169	0.112	0.000	0.672	0.397	0.006	0.721			
SN	0.270	0.259	0.354	0.406	0.024	0.125	0.594	0.007	0.675		
PU	0.317	0.358	0.549	0.220	0.077	0.224	0.266	0.042	0.494	0.756	
SP	0.293	0.386	0.554	0.130	0.135	0.296	0.200	0.102	0.333	0.518	0.681

Appendix 9 Discriminant validity (article 4)

Construct	PU	ENJ	SI	PCM	PEOU	SE	INT
PU	0.789						
ENJ	0.790	0.886					
SI	0.510	0.469	0.829				
PCM	0.506	0.448	0.673	0.786			
PEOU	0.483	0.543	0.252	0.306	0.837		
SE	0.315	0.375	0.141	0.199	0.723	0.890	
INT	0.597	0.669	0.361	0.398	0.583	0.494	0.882

Research article 1

Merikivi, J. – Mäntymäki, M. (2009)

Explaining the Continuous Use of Social Virtual Worlds: An Applied Theory of Planned Behavior Approach, In *the proceedings of the 42nd Annual Hawaii International Conference on System Sciences*, Computer Society Press, Waikoloa, Big Island, Hawaii, 5.–8.1.2009.

Reprinted with permission from (© 2009) IEEE.

Explaining the Continuous Use of Social Virtual Worlds: An Applied Theory of Planned Behavior Approach

Jani Merikivi
Turku Centre for Computer Science
jani.merikivi@tse.fi

Matti Mäntymäki
Turku School of Economics
Turku Centre for Computer Science
matti.mantymaki@tse.fi

Abstract

Social virtual worlds (SVWs) have become increasingly popular spaces for social interaction. To be attractive to engage with, maintaining a sufficient base of active users is a sine qua non. Using Habbo as an example, this paper develops a framework for investigating the continuous use of social virtual worlds. Based on a detailed review of literature, we propose that a decomposed theory of planned behavior complemented with critical mass and allure of competitors would be an applicable theoretical lens to explain why users continuously engage with a social virtual world. We suggest that the social aspects are of particular importance in determining the continuous use of SVWs. This research attempts to build a theoretical foundation for further studies empirically investigating the phenomenon.

1. Introduction

Besides entertainment, social virtual worlds – a subset of virtual world used in relation to game worlds – have become convenient and prominent spaces for social interaction. Habbo, one of the world's largest social virtual worlds for teens, has now spread to 32 countries around the world and reached almost 10 million monthly unique visitors aged 13–18 [1].

Social virtual worlds (SVWs), many of which provide a platform that is more an extension of reality than just a fantasyland, are persistent computer-mediated communities simulating an environment that use elements of gaming [2, 3]. Contrary to games, there are no specific goals.

Apart from the game immersion, SVWs could be compared to virtual communities; “social aggregations that emerge from the net when enough people carry on

those public discussions long enough, with sufficient human feeling, to form webs of personal relationships in cyberspace.” [4] Each and every individual is important in volitionally participating and meeting with new and old friends within the community and creating, sharing, reflecting, and consuming the interesting content influenced by norms, values, and offline life [e.g. 5–8].

In a business that relies on access fees, commercials and premium services, the social outcomes, extended play and loyalty that result from members engaged with an SVW is translated directly into monetary value [cf. 6, 9]. For example, Habbo, one of the world's largest social virtual worlds, collects no access fee but offers virtual furniture for decorating user-generated virtual rooms, tickets to play in-world games, and voluntary memberships allowing members to additional benefits not available to non-subscribers. All these can be bought with Habbo credits, the SVW's virtual currency purchased with real-life money.

Investigating technology acceptance and adoption has evolved into one of the most prominent research streams within the information systems (IS) discipline [10, 11]. However, recent IS literature has shown increasing interest to post-adoption behavior [cf. e.g., 10, 12, 13] and IS continuance [14, 15].

Technology access is suggested as one of the major issues in IS proposals [16]. However, focusing only technology access and adoption omits the continued intention to use such technologies [e.g. 12, 17, 18, 19].

We argue that objectives such as competitive advantage from virtual social worlds occur only through continued use – not just adoption or acceptance. Currently, prior literature provides a limited theoretical understanding of sustaining continued use among those using social virtual worlds.

As a result, the purpose of this paper is to develop a framework to answer the following high-level research question: *why do users continuously engage with social virtual worlds?*

This paper has two primary goals; firstly, by reviewing prior literature, to identify a set of factors that may affect continuous use of social virtual worlds, and secondly, by using the identified factors to develop a research model that could be used in empirical investigation.

In this paper, we investigate one social world virtual, Habbo, since the first subsequent empirical research is planned to be conducted among the members of Habbo. Moreover, since our focus is particularly on the post-adoption behavior and empirical research will be conducted among active users of Habbo, we do not discuss initial acceptance or adoption.

Regarding the contribution of this paper, understanding the process toward the continued use of social virtual worlds may be beneficial in designing new features and services for SVWs. Particularly since this issue has not been widely covered by prior research, the attempt made in this paper to address this gap in the literature may be valuable. For public policy makers, understanding what factors affect continued use behavior among users is viable with regard to successfully planning and implementing initiatives involving considerable resources, such as those striving to provide youth services in virtual social worlds and communities. As stated by Hsieh, Rai & Kiel [20], a policy that focuses only on reducing or eliminating barriers to technology access is only part of the solution.

From a more theoretical perspective, our paper aims to make a contribution by identifying the factors behind the continued use of social virtual worlds and thus laying a foundation for further studies. Secondly, we develop a research model that could be utilized in investigating other online services on which the social aspect is expected to have a strong influence. Thirdly, by particularly focusing on existing active users it increases the understanding of post-adoption user behavior, an emergent topic in the contemporary information system and e-business research. [cf. e.g., 14, 15, 18.]

2. Background

Prior studies, in attempting to understand sustained attraction of virtual communities have focused on the unique characteristics such as social atmosphere with various methods [e.g., 5, 21]. To complement these existing conceptual approaches and to focus more

explicitly on understanding the role of attitudes, social influence, and behavioral control on continued use, we pay attention to the frameworks originated in social psychology, such as the technology acceptance model (TAM) [22, 23], the theory of reasoned action (TRA) [24, 25, 26], and the theory of planned behavior (TPB) [27, 28]. These frameworks have been widely applied when studying information and communication technology acceptance, including post-adoption behavior by individuals who already have experience with the technology [i.e., 19, 29, 30, 31].

In this paper, we apply the theory of planned behavior (TPB) as the theoretical foundation of our model. TPB has shown to conform to technology acceptance among individuals with IT usage experience in homes [31, 32]. Moreover, we include additional components from perceived critical mass [33] to build a framework for scrutinizing the individual's intention to continued use of social virtual worlds.

As argued by Benbasat and Zmud [34], the usage context of the IT artifact is an important factor in explaining user behavior. Consequently, we have chosen TPB as the foundation of our research model since it suits the usage context well. First of all, the use of social virtual worlds is of a hedonic and voluntary nature. Yet, users may view their use of social virtual worlds as also including utilitarian motives; the usage context is, at any rate, leisure-oriented rather than work-oriented.

Secondly, we assume that the social aspects of usage are of particular importance. Compared to, e.g., TAM, TPB takes the social influence affecting SVW usage better into account, by investigating the subjective norm – the degree to which an individual believes that people who are important should perform the behavior in question [26, 28]. Moreover, in original TAM, as the intention to use is determined by two factors – perceived usefulness and perceived ease of use – TPB enables the making of a distinction between hedonic and utilitarian motives. As argued by Benbasat and Barki [34], in TAM, perceived usefulness and perceived ease of use are often viewed as 'black boxes'. Thus, TPB can perhaps provide a more fine-grained illustration of the determinants of the attitude.

Complementing perceived usefulness and ease of use with perceived enjoyment has proven viable in a hedonic setting. Therefore, in order to take the hedonic and social aspects into account, the original TAM would have needed considerable modifications. Moreover, since our framework explores components from several theories, using TPB as the core of the model instead of TAM, we hope to build our model on a more stable ground.

Agreeing with Shimp and Kavas [36] that cognitive constructs of belief could not be combined to single conceptual factor, we follow Taylor and Todd [37, 38], Venkatesh and Brown [32], and Hsieh et al. [20] who deconstructed the underlying TPB belief constructs. We argue that a decomposed TPB, adapted from TPB, offers comprehensive information on belief determinants of SVW's continuous intention. Based on a detailed literature review, we decomposed the three TPB belief constructs – attitude (ATT), subjective norm (SN), and perceived behavior control (PBC) – to provide a satisfactory explanation in the formulation of our model.

In our research model, the TPB framework is complemented with two determinants of attitude, social outcomes and trust. Moreover, we have also included components from innovation diffusion theory and perceived critical mass [33]. The research model is discussed in detail in the following chapter.

3. The research model

3.1. The Attitudinal Belief Structure

According to TPB, behavioral intention (BI) is determined by three factors, attitude (ATT), perceived behavioral control (PBC) and subjective norm (SN) [24, 25, 26, 27, 28]. Earlier research on TPB has concentrated mainly on technology adoption among first-time users. With this paper, we attempt to extend the theory to reflect also the continued use of technology that has similarities with earlier TPB research. [cf. e.g. 20.] Thus, we postulate the three first hypotheses accordingly:

H1: Attitude towards continuous use of the SVW positively affects the continuance intention.

H2: PBC positively affects the continuance intention.

H3: SN positively affects the continuance intention.

Individuals use information technology from both extrinsic and intrinsic motivation perspectives [39, 40]. Extrinsic motivation pertains to achievement of a specific goal, whereas intrinsic motivation is the pleasure, joy, playfulness, and satisfaction derived from a specific behavior [40, 41, 42, 43]. Teo, Lim, and Lai [44] empirically verified that intrinsic motivation has a significant effect on computer and internet usage. The distinction between extrinsic and intrinsic motivation has been articulated also in consumer behavior [45, 46] and IS literature on technology acceptance [20, 32, 39, 47].

Drawing on this body of research, we assume that the continuous use of SVWs is influenced by both extrinsic and intrinsic motivation, i.e. utilitarian and hedonic outcomes. Juxtaposed with workplace IT, we

assume that the adoption of SVWs is not driven by a strong productivity orientation [32], but other utilitarian motives such as the opportunity to effectively communicate, share member-generated information and knowledge [5, 23, 32] and social interaction [8]. Finally we conclude with the respective hypothesis:

H4: Utilitarian outcomes positively affect the attitude toward continuous use of the SVW.

Perceived enjoyment represents the intrinsic motivation and is defined as hedonic, the extent to which participating in online communities is perceived pleasurable and satisfying. Prior research has shown that the use of IT was influenced by perceived enjoyment, not only to improve performance [39, 48, 49, 50]. In the context of SVWs, Mr. Sulka Haro [51], the lead designer on Habbo, described in his keynote presented at GDC08 conference that members for example, seek a playful job or task inside the world in a form of a reciprocal role play. They may work as bartenders in virtual bars or organize beauty contests with their Habbo friends in self-decorated virtual rooms. Using Habbo credits for decorating rooms or dressing avatars is not only for enjoyment itself, but closely intertwined to such role-playing activities. As a result, we assume that the hedonic outcomes, particularly the enjoyment, are important in determining the continuous use of SVWs. Thus, we hypothesize that:

H5: Hedonic outcomes positively affect the attitude toward continuous use of the SVW.

Prior IT and innovation research suggests that social status, extrinsic of nature, is conferred on individuals as a result of adopting a technological innovation [e.g., 32, 52, 53, 54]. In SVWs, the content members create and share through participation influence their status. For example, in a three-dimensional Habbo teenagers can, via customizable animated avatars, decorate their private rooms and take part in activities, events, games and competitions created by the designers or the users themselves.

However, there is a growing understanding of intrinsic social outcomes such as support, affiliation, and connectedness in bringing together individuals online and offline [e.g., 4, 5, 6, 8, 55]. They spend considerable time maintaining existing friendships and making new ones in a search for proximal and distal companionship, support, and affiliation, reflecting their need for belonging [cf. 8, 56, 57]. Such social connectedness represents subjective awareness of interpersonal closeness [57, 58], and a personal sense of identity and place [59, 60]. The information-related [61] facets of cognitive and relational dimension are excluded, as they would otherwise overlap the extrinsic beliefs.

In the context of SVW engagement, social needs are derived from extrinsic and intrinsic into social outcomes category that includes the belief constructs of status and connectedness. We will presume that strong perceived status and connectedness will positively affect the engagement with an SVW. As a result, we hypothesize that:

H6: Social outcomes positively affect the attitude toward continuous use of the SVW.

Trust is a central element of all human interaction [62, 63]. Trust is a key ingredient of social capital which in turn has been identified to play a role also with online communities [62, 64, 65, 66].

Trust has been identified to be an important factor not only in e-commerce acceptance [67, 68], but also in ongoing exchange relationships [69, 70]. SVW is not only an online service or Internet merchant, but also a social system. Therefore, in addition to trust in the service provider, in terms of social capital, trust other users of the SVW is important.

Based on these arguments, we have included trust as an antecedent of attitude in the research model. In this research, we investigate trust only as a set of trusting beliefs [cf. e.g., 71, 72] in Habbo as well as in its other users. In this paper, we have excluded the dispositional and institutional dimensions of trust. Moreover, we do not investigate the behavioral intention related to trust, but position trust as a determinant of attitude and accepted the definition of trust by Maier et al. [73]. Therefore, the respective hypothesis is formulated as follows:

H7: Trust positively affects the attitude toward continuous use of the SVW.

3.3. The Behavioral Control Belief Structure

Perceived behavioral control (PBC) can be conceptualized as the ease or difficulty in conducting certain behavior [28]. Self-efficacy has been viewed as the main factor of PBC [74, 75]. Compeau and Higgins [61] define computer self-efficacy as "an individual's perception of his or her ability to use a computer in the accomplishment of a job task". We adopt this definition to be applied also in SVW context. However, instead of accomplishing a job task, in our research self-efficacy refers to his/her confidence in using the SVW. Thus, the respective hypothesis is postulated as follows:

H8: SVW self-efficacy positively affects PBC.

As stated by van der Heijden [47], perceived ease of use (PEOU) plays a pivotal role in the user acceptance of hedonic information systems. In this research, we investigate PEOU as an antecedent of

perceived behavioral control. [20.] As a result, we hypothesize that:

H9: Perceived ease of use positively affects PBC.

Taylor & Todd [38] and Hsieh et al. [20] identified that availability of the technology needed to use the service has a positive influence on PBC. [20.] Thus, the tenth hypothesis is postulated as follows:

H10: Availability positively affects PBC.

3.4. The Normative Belief Structure

SVW usage can be derived from individual's voluntariness, which suggests that users perceive the adoption decision to be non-mandatory. However, as supported by extensive prior research [e.g., 20, 32, 76], social norms positively influence an individual's IT usage.

Social influence is the extent to which members of a social network influence one another's behavior [77]. In contrast to social outcomes, social influence is the perceived pressure to perform the behavior in question. The importance of social influence as a determinant of behavior has been highlighted in prior research [e.g., 20, 26, 27, 28, 32, 37, 78]. Thus, we can expect IT adoption decisions to be influenced by the views of relevant others, such as friends and family members [e.g. 20; 79, 80]. For many, the community itself acts as an important reference group for its members – even replacing other influential reference groups [e.g. 5, 81]. Members feel that they are connected to other members [8].

Therefore, we hypothesize as follows:

H11: Referents' influence positively affects subjective norm.

Prior research has identified secondary sources of information – such as TV and newspapers – as influential in early adopters' decisions to adopt [32, 53]. In the context of continuous use, we expect that those already using SVWs may as well be influenced by the secondary information sources, i.e. mass media, because information about alternative SVWs is not yet available among those individuals. As a result, the twelfth hypothesis is postulated as follows:

H12: Secondary sources of information negatively affect subjective norm.

Construct	Conceptualization	Source
Attitude	The degree to which the behavior of interest is valued	[28]
Utilitarian outcomes	The degree to which using SVW enhances the effectiveness of the personal related activity, such as information sharing.	[5, 23, 32]
Hedonic outcomes	The degree to which the enjoyment is derived from SVW usage	[32, 39, 49]
Social outcomes	The degree to which the status of an individual is conferred on using SVW	[32, 57, 58]
Trust	Willingness to be vulnerable to the actions of another party; set of trusting beliefs.	[67, 68, 73]
Subjective norm	The perceived social pressure to engage with SVW	[28]
Referents' influence	The degree to which other individuals influence on using SVW	[12, 20, 32, 38]
Secondary information	The degree to which mass media (TV, Radio etc.) influence the use of SVW	[32]
Perceived behavioral control	The perception of the ability to use SVW	[28]
Self-efficacy	The degree to which an individual is capable of using SVW	[61, 74, 75]
Perceived ease of use (PEOU)	The degree to which an individual perceives using SVW is free of effort	[22, 23, 47]
Availability	The availability of technology to use SVW	[20, 38]
Perceived quality of competitors	The degree to which other alternatives influence the use of SVW	[53, 90]
Perceived critical mass	The perceived minimum amount of users needed to use SVW	[20, 33, 53, 83]
Continuance intention	The intention to participate and continue using SVW	[20]

Table 1. Summary of the constructs

3.5. Perceived critical mass and competitors

TPB has limitations in regarding the realization of decisions; one-dimensional belief structures have turned out to be problematic [e.g. 5, 38]. To overcome such challenges, prior studies of IT adoption [23, 37, 38, 52, 82] have attempted to identify the beneficial factors of attitudinal beliefs by applying the Rogers' [53] theory on diffusion of innovations (DOI). However, DOI has been noted to remain silent on how attitudes are formed [12], and, in the context of interactive innovations, continuous use is not ambiguously related solely to attitudinal beliefs, but is influenced by other factors such as the critical mass as well [see 53, 83].

As the content in these dynamic services is produced by the users, referring to Metcalfe's law [cf. e.g. 84], the number of users in very general terms increases the value that SVW is able to deliver to its users. For example, the SVW may lose its relative advantage over competitors if a certain number of other members with whom an individual particularly wants to interact stop using it [see 85, 86, 87]. Consequently, members are not perceived as equal: a small group of close members congregated at the SVW may have a stronger influence than an equally sized group of distant members [53]. Without losing such cohesion between the critical members, SVWs are perceived as reaching and adhering to them with scalability tools, such as search engines and directories – if not complex themselves [6, 88, 89]. Consequently, the key challenge the maintainers of these services are facing is to transfer from attracting new users towards retaining the important existing ones.

Similarly to Hsieh et al. [20] and [33], perceived critical mass is operationalized in our research as the degree to which a person believes that most of his or her peers are using the particular innovation [33]. In comparison to the subjective norm, PNE captures the aggregate personal network exposure [20]. Hence, a member is likely to discontinue using the SVW if such relative advantage over alternatives cannot be perceived and results in a replacement. This indicates the fact that decisions on continuance made voluntarily are not done in a vacuum but are influenced by the existence of alternate SVWs [cf. e.g. 90] and perceived critical mass [33].

Thus, we propose that perceived quality of competitors and losing the perceived critical mass negatively affects the intention of continued use by causing cognitive uncertainty and difficulty in determining which SVW to use. Consequently, the last two hypotheses to complement the TPB framework are postulated as follows:

H13: Critical mass positively affects the continuance intention.

H14: Perceived quality of competitors negatively affects the continuance intention.

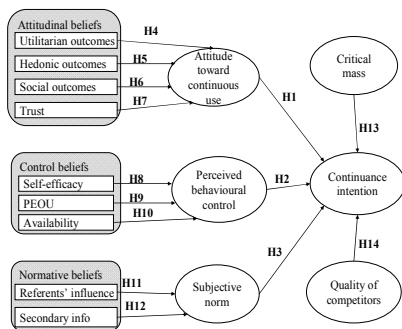

Figure 1. The research model

4. Discussion and further research

4.1. Implications

This paper contributes to the literature on social virtual worlds and the research stream within the IS literature focusing on continuous use of information systems associated with home and leisure activities [47]. Based on a detailed literature review, the paper develops and introduces a research model designed for investigating the continuous use of SVWs. Firstly, we discuss the nature and use context of SVWs and possible theoretical frameworks. As a result, we propose a framework from decomposed TPB, complemented with components from critical mass, that is well suited to capture the voluntary, hedonic and social nature of SVWs.

Since the use of SVWs has not been extensively investigated in the prior IS literature, our paper explores a relatively new area of research. In this regard, developing the model and identifying the relevant constructs can be considered the main theoretical contribution of our research.

In particular, in our research model we highlight the social aspect associated with the use of SVWs, by investigating it through two lenses: subjective norm and critical mass. Moreover, our research focuses especially on the young, who have had been given only minimal attention in prior IS research in real-life setting, unlike elderly consumers [cf. 91]. The focus on youth comes from the fact that they form the majority of SVW users. In the case of Habbo, the users are teenagers and the actual users are surveyed.

From a managerial perspective, our paper is one of the first attempts to identify the predictors of continuous use of SVWs. Understanding the factors that influence users' engagement with the SVW can help the maintainers to develop attractive features and services to keep users loyal.

4.2. Limitations & further research

Self-evidently, this research suffers from several limitations. Since this paper was solely of conceptual nature aiming to develop a research model, it provides no empirical evidence to support or reject the model. Since the SVW framework in this research is primarily aimed at the young, the results cannot be generalized to the whole population.

Moreover, the young diversified members are expected to engage SVWs at different times and for various reasons. As identified by Citrin, Spritt, Silverman & Stem [92] and Goldsmith and Hofacker [93, 94], the individual's innovativeness is a domain-specific issue, implying that individuals who are likely to adopt the latest innovation and discontinue using another in one field may be laggards in another [95, 96]. Thus, we suggest that they could be described and classified in terms of innovativeness [53], explaining how the perceived attributes of SVW have an effect on its rate of continued use. However, we did not include this aspect in our research model, as we believe that distributing users based on their innovativeness could potentially provide insightful results, not forgetting that the users of successful SVWs are for the most part relatively young. Consequently, drawing generalizations to the whole population is not of the highest relevance. Due to limited space, only the TPB-based core of the model was presented in this paper.

Since SVWs and the field of social media is not a monolithic, we suggest including additional variables in the research model and testing it in various contexts such as online communities and massively multi-player online role-playing games (MMORPGs) in order to further improve its explanatory power.

The research process will continue from by empirically testing the research model. The empirical research will be conducted by distributing an online questionnaire for the users of Habbo in 5-7 countries from different continents. Thereafter, the aim is to further test the applicability of the model will be further tested among users of an online community targeted for users 16 to 40 years of age, the average being approximately age 20.

5. Conclusions

This paper has identified and articulated the reasons for continuous engagement with social virtual worlds as well as presenting a research model for this purpose. As the research process will continue by empirically testing the model, the authors would be highly appreciative of any feedback from the academic community that helps to improve the quality of their work.

Reference

- [1] Sulake Corporation, "Habbo - Where else", 2008 (retrieved June 12, 2008, <http://www.sulake.com/habbo/?navi=2>).
- [2] Bartle, R.A. *Designing Virtual Worlds*, New Riders, Indianapolis, 2003.
- [3] B. Book, "Moving Beyond the Game: Social Virtual Worlds", In: *State of Play 2 Conference*, 2004.
- [4] Rheingold, H. *The Virtual Community: Homesteading on the Electronic Frontier*, The MIT Press, Cambridge, MA, 2000.
- [5] R.P. Bagozzi and U.M. Dholakia, "Intentional social action in virtual communities", *Journal of Interactive Marketing*, 16(2), 2002, pp. 2–21.
- [6] Hagel J. and A.G. Armstrong, *Net gain: expanding markets through virtual communities*. Harvard Business School Press, Boston MA, 1997.
- [7] J. Preece, *Online communities: Designing usability, supporting sociability*, John Wiley & Sons, New York NY, 2000.
- [8] Wellman, B and M. Gulia, "Net-surfers don't ride alone: Virtual communities as communities. In: *Communities and Cyberspace*, ed. Kollock, P. and M. Smith, Routledge, New York NY, 1999.
- [9] S. Humphreys, "Ruling the virtual world. Governance in massively multiplayer online games", *European Journal of Cultural Studies*, 11(2), 2008, pp. 149–171.
- [10] J. Jasperson, P.E. Carter and R.W. Zmud, "A comprehensive conceptualization of post-adoptive behaviors associated with information technology enabled work systems", *MIS Quarterly*, 29(3), 2005, pp. 525-557.
- [11] V. Venkatesh, M.G. Morris, G.B. Davis and F.D. Davis, "User acceptance of information technology: Toward a unified view", *MIS Quarterly*, 27(3), *MIS Quarterly & The Society for Information Management*, 2003, pp. 425-478.
- [12] E. Karahanna, D.W. Straub and N.L. Chervany, "Information technology adoption across time: a cross-sectional comparison of pre-adoption and post-adoption beliefs", *MIS Quarterly*, 23(2), 1999, pp. 183-213.
- [13] M. Parthasarathy & A. Bhattacharjee, "Understanding post-adoption behavior in the context of online services", *Information Systems Research*, 9(4), 1998, pp. 362-379.
- [14] M. Limayem, S.G. Hirt and C.M.K. Cheung, "How habit limits the predictive power of intention: The case of information systems continuance", *MIS Quarterly*, 31(4), 2007, pp. 705-737.
- [15] G. Premkumar and A. Bhattacharjee, "Explaining information technology usage: test of competing models", *Omega*, 36(1), 2008, pp. 64-75.
- [16] P. DiMaggio, E. Hargittai, W.R. Neuman, and J.P. Robinson, "Social Implication of the Internet", *Annual Review of Sociology*, 27(1), 2001, pp. 307–336.
- [17] R. Agarwal and J. Prasad, "The Role of Innovation Characteristics and Perceived Voluntariness in the Acceptance of Information Technology", *Decision Sciences*, 28(3), 1997, pp. 557–582.
- [18] A. Bhattacharjee, "An empirical analysis of the antecedents of electronic commerce service continuance", *Decision Support Systems*, 32(2), 2001, pp. 201-214.
- [19] B. Szajna, "Empirical evaluation of the revised TAM", *Management Science*, 42(1), 1996, pp. 85–92.
- [20] J.J.P. Hsieh, A. Rai and M. Keil, "Understanding digital inequality: Comparing continued use behavioral models of the socio-economically advantaged and disadvantaged", *MIS Quarterly*, 32(1), *MIS Quarterly & The Society for Information Management*, 2008, pp. 97-126.
- [21] Wellman, B., *The network community: An introduction to networks in the global village*, In: *Networks in the global village*, ed. Wellman, B., Westview Press, Boulder CO, 1999.
- [22] F.D. Davis, R.P. Bagozzi, and P.R. Warshaw, "User acceptance of computer technology: A comparison of two theoretical models", *Management Science*, 35(8), 1989, pp. 982–1003.
- [23] F.D. Davis, "Perceived Usefulness, Perceived Ease of Use, and User Acceptance of Computer of Information Technology", *MIS Quarterly*, 13(3), 1989, pp. 319–339.
- [24] I. Ajzen and M. Fishbein, "Attitudinal and normative variables as predictors of specific behavior", *Journal of Personality and Social Psychology*, 27(1), 1973, pp. 41–57.
- [25] Fishbein, M., *Attitude and the prediction of behaviour*. In: *Readings in attitude theory and measurement* (pp. 477–492), ed. M. Fishbein, Wiley, New York NY, 1967

- [26] Fishbein, M. and I. Ajzen, *Belief, Attitude, Intention, and Behavior: An introduction to the Theory and Research*, Addison-Wesley, Reading MA, 1975.
- [27] Ajzen, I., *From intentions to actions: A theory of planned behavior*, In: Springer series in social psychology (pp. 11–39), ed. J. Kuhl and J. Beckmann, Springer, Berlin, 1985
- [28] I. Ajzen, “The theory of planned behavior”, *Organizational Behavior and Human Decision Processes*, 50(2), 1991, pp. 179–211.
- [29] A. Bhattacharjee, “Understanding Information Systems Continuance: An Expectation-Confirmation Model”, *MIS Quarterly*, 25(3), 2001, pp. 251–370.
- [30] S.-J. Hong, J.Y.L. Thong, and K.Y. Tam, “Understanding continued information technology usage behavior: A comparison of three models in the context of mobile internet”, *Decision Support Systems*, 42(3), 2006, pp. 1819–1834.
- [31] S. Taylor and P.A. Todd, “Assessing IT Usage: The Role of Prior Experience”, *MIS Quarterly*, 19(4), 1995, pp. 561–570.
- [32] V. Venkatesh and S.A. Brown, “A Longitudinal Investigation of Personal Computers in Homes: Adoption Determinants and Emerging Challenges”, *MIS Quarterly*, 25(1), 2001, pp. 71–102.
- [33] H. Lou, W. Lou, and D. Strong, “Perceived Critical Mass Effect on Groupware Acceptance”, *European Journal of Information Systems*, 9(2), 2000, pp. 91–103.
- [34] I. Benbasat and R.W. Zmud, “The identity crisis within the IS discipline: Defining and communicating the discipline's core properties”, *MIS Quarterly*, 27(2), 2003, pp. 183–194.
- [35] I. Benbasat and H. Barki, “Quo vadis, TAM?”, *Journal of the Association for Information Systems*, 8(4), 2007, pp. 211–218.
- [36] T. Shimp and A. Kavas, “The Theory of Reasoned Action Applied to Coupon Usage”, *Journal of Consumer Research*, 1984, 11(3), pp. 795–809.
- [37] P.A. Todd and S. Taylor, “Decomposition and crossover effects in the theory of planned behaviour: A study of consumer adoption intentions”, *International Journal of Research in Marketing*, 12(2), 1995, pp. 137–155.
- [38] S. Taylor and P.A. Todd, “Understanding Information Technology Usage: A Test of Competing Models”, *Information Systems Research*, 6(2), 1995, pp. 144–176.
- [39] F.D. Davis, R.P. Bagozzi, and P.R. Warshaw, “Extrinsic and Intrinsic Motivation to Use Computers in Workplace”, *Journal of Applied Social Psychology*, 22(14), 1992, pp. 1111–1132.
- [40] R.J. Vallerand, “Toward a Hierarchical Model of Intrinsic and Extrinsic Motivation”, *Advances in Experimental Social Psychology*, (29), 1997, pp. 271–360.
- [41] M. Igbaria, J. Iivari, and H. Maragahh, “Why do individuals use computer technology? A Finnish case study”, *Information & Management*, 25(5), 1995, pp. 227–238.
- [42] Deci, E.L., *Intrinsic Motivation*, Plenum Press, New York NY, 1975.
- [43] Deci, E.L. and R.M. Ryan, *The empirical Exploration of Intrinsic Motivational Processes*, In: *Advances in Experimental Social Psychology* (pp. 39–80), ed. L. Berkowitz, Academic Press, New York NY, 1980.
- [44] T.S.H. Teo, V.K.G. Lim, and R.Y.C. Lai, “Intrinsic and extrinsic motivation in Internet usage”, *Omega*, 27(1), 1999, pp. 25–37.
- [45] E.C. Hirschman and M.B. Holbrook, “Hedonic Consumption: Emerging Concepts, Methods and Propositions”, *Journal of Marketing*, 46(1), 1982, pp. 92–101
- [46] M.P. Venkatraman and D.J. McInnis, “The Epistemic and Sensory Exploratory Behaviors of Hedonic and Cognitive Consumers”, *Advances in Consumer Research*, 12(1), 1985, pp. 102–107.
- [47] H. van der Heijden, “User acceptance of hedonic information systems”, *MIS Quarterly*, 28(4), *MIS Quarterly & The Society for Information Management*, 2004, pp. 695–704.
- [48] V. Venkatesh and C. Speier, “Computer Technology Training in the Workplace: A Longitudinal Investigation of the Effect of Mood”, *Organization Behavior and Human Decision Processes*, 79(1), 1999, 1–28.
- [49] M. Igbaria, S.J. Schiffman, and T.J. Wieckowski, “The respective roles of perceived usefulness and perceived fun in the acceptance of microcomputer technology”, *Behavior and Information Technology*, 17(6), 1994, pp. 349–361.
- [50] C.-L. Hsu and H.-P. Lu, “Consumer Behavior in online game communities: A motivational factor perspective”, *Computers in Human Behavior*, 23(3), 2007, pp. 1642–1659.
- [51] GDC08, *The State of the Hotel – What Makes Teens Tick at HABBO*, (retrieved June 13, 2008 <http://www.massively.com/2008/02/19/gdc08-sulka-haro-tells-us-how-to-habbo/>).
- [52] G.C. Moore and I. Benbasat, “Development of an instrument to measure perceptions of adopting an information technology innovation”, *Information Systems Research*, 2(3), 1991, pp. 192–222.
- [53] Rogers, E.M., *Diffusion of Innovations*, Free Press, New York NY, 2003.
- [54] V. Venkatesh and F.D. Davis, “A Theoretical Extension of the Technology Acceptance Model: Four

Longitudinal Field Studies", *Management Science*, 46(2), 2000, pp. 186–204.

[55] C-M. Chiu, M-H. Hsu, and E.T.G. Wang, "Understanding knowledge sharing in virtual communities: An integration of social capital and social cognitive theories", *Decision Support Systems*, 42(2), 2006, pp. 1872–1888.

[56] R.F. Baumeister and M.R. Leary, "The need to belong: Desire for interpersonal attachments as a fundamental human motivation", *Psychological Bulletin*, 117, 1995, pp. 497–529.

[57] R.M. Lee and S.B. Robbins, "Measuring Belongingness: The Social Connectedness and Social Assurance Scales", *Journal of Counseling Psychology*, 42(2), 1995, pp. 232–241.

[58] R.M. Lee and S.B. Robbins, "The relationship between social connectedness, self-esteem, and social identity", *Journal of Counseling Psychology*, 45(3), 1998, pp. 338–345.

[59] Kohut, H., *How Does analysis cure?* International Universities Press, New York NY, 1984.

[60] Wolf, E., *Treating the self: Elements of clinical self psychology*, Guilford Press, New York NY, 1988.

[61] D. Compeau and C.A. Higgins, "Application of Social Cognitive Theory to Training for Computer Skills", *Information Systems Research*, 6(2), 1995, pp. 118–143.

[62] Fukuyama, F. *Trust: The Social Virtues and the Creation of Prosperity*, Free Press, New York, 1995.

[63] D.L. Cowles, "The role of trust in customer relationships: Asking the right questions", *Management Decision*, 35(4), 1997, pp. 273-282.

[64] C. Wiertz and K. de Ruyter, "Beyond the call of duty: Why customers contribute to firm-hosted commercial online communities", *Organization Studies*, 28(3), 2007, pp. 347.

[65] I.Y.L. Chen, "The factors influencing members' continuance intentions in professional virtual communities - a longitudinal study", *Journal of Information Science*, 33(4), 2007, pp. 451.

[66] M.M. Wasko and S. Faraj, "Why should i share? examining social capital and knowledge contribution in electronic networks of Practice", *MIS Quarterly*, 29(1), 2005, pp. 35.

[67] D. Gefen, E. Karahanna and D.W. Straub, "Trust and TAM in online shopping: An integrated model", *MIS Quarterly*, Minneapolis, 27(1), 2003, pp. 51-90.

[68] P.A. Pavlou, "Consumer acceptance of electronic commerce: Integrating trust and risk with the technology acceptance model", *International Journal of Electronic Commerce*, 7(3), M.E. Sharpe Inc, 2003, pp. 101-134.

[69] R.M. Morgan and S.D. Hunt "The commitment-trust theory of relationship marketing", *Journal of Marketing*, 58(3), 1994, pp. 20-40.

[70] F.R. Dwyer, P.H. Schurr, and S. Oh, "Developing buyer-seller relationships", *Journal of Marketing*, 51(2), 1987, pp. 11.

[71] D.H. McKnight and N.L. Chervany, "What trust means in E-commerce customer relationships: An interdisciplinary conceptual typology" *International Journal of Electronic Commerce*, 6(2), 2001, pp. 35-59.

[72] D.H. McKnight, V. Choudhury and C. Kacmar "Developing and validating trust measures for e-commerce: An integrative typology" *Information Systems Research*, 13(3), 2002, pp. 334-359.

[73] R.C. Mayer, J.H. Davis and F.D. Schoorman, "An integration model of organizational trust" *The Academy of Management Review*, 20(3), 1995, pp. 709-735.

[74] A. Bandura, "Toward a unifying theory of behavioural change", *Psychological Review*, 84(2), 1977, pp. 191–215.

[75] Bandura, A., *Self-Efficacy: The Exercise of Control*, Freeman, New York NY, 1997.

[76] V. Venkatesh and M.G. Morris, "Why Don't Men Ever Stop to Ask for Directions? Gender, Social Influence, and Their Role in Technology Acceptance and Usage Behavior", *MIS Quarterly*, 24(1), 2000, pp. 115–139.

[77] R.E. Rice, A.E. Grant, J. Schmitz, and J. Torobin, "Individual and Network Influences on the Adoption and Perceived Outcomes of Electronic Messaging", *Social Networks*, 12(1), 1990, pp. 27–55.

[78] R.L. Thompson, C.A. Higgins, and J.M. Howell, "Personal Computing: Toward a Conceptual Model of Utilization", *MIS Quarterly*, 15(1), 1991, pp. 124–143.

[79] R.E. Burnkrant and A. Cousineau, "Informational and Normative Social Influence in Buyer Behavior", *Journal of Consumer Research*, 2(2), 1975, pp. 206–215.

[80] T.L. Childers and A.R. Rao, "The Influence of Familiar and Peer-Based Reference Groups on Consumer Decisions", *Journal of Consumer Research*, 19(2), 1992, pp. 198–211.

[81] D. Constant, L. Sproull, and S. Kiesler, "The kindness of strangers: The usefulness of electronic weak ties for technical advice", *Organization Science*, 7(2), 1996, pp. 119–135.

[82] L.G. Tornatzky and K.J. Klein, "Innovation Characteristics and Innovation Adoption-Implementation: A Meta-Analysis of Findings", *IEEE Transactions on Engineering Management*, 29(1), 1982, pp. 28–45.

- [83] M.L. Markus, "Toward a 'Critical Mass' Theory of Interactive Media: Universal Access. In: Organizations and Communication Technology (pp. 194–218), ed. J. Fulk and C. Steinfield, Sage, Newbury Park CA, 1990.
- [84] Shapiro, C. and H.R. Varian, *Information Rules: A Strategic Guide to the Network Economy*, Harvard Business School Press, Boston MA, 1999.
- [85] S.M. Granovetter, "The Strength of Weak Ties", *American Journal of Sociology*, 78(6), 1973, pp. 1360–1380.
- [86] S.M. Granovetter, "Threshold Models of Collective Behavior", *American Journal of Sociology*, 83(6), 1978, pp. 1420–1443.
- [86] S.M. Granovetter and R. Soong, "Threshold Models of Diffusion and Collective Behavior", *Journal of Mathematical Sociology*, 9, 1983, pp. 165–179.
- [87] M.L. Markus, "Toward a 'Critical Mass' Theory of Interactive Media: Universal Access, Interdependence and Diffusion", *Communication Research*, 14(5), 1987, pp. 491–511.
- [88] J. Hummel and U. Lechner, "Social Profiles of Virtual Communities", In: 35th Annual Hawaii International Conference on Systems Sciences (HICCS'02), R. Sprague (Ed.), IEEE Press, Hilton Waikoloa Village, 2002.
- [89] E. Noam, "Innovation, Networks, and Organizational Learning", In: *The Economics of Information Networks* (pp. 91–102), ed. C. Antonelli, Elsevier Science Publishers, Amsterdam, 1992.
- [90] D. Li, G.J. Browne and P.Y.K. Chau, "An empirical investigation of web site use using a commitment-based model", *Decision Sciences*, 37(3), 2006, pp. 427–444.
- [91] D.W. McCloskey, "The importance of ease of use, usefulness, and trust to online consumers: An examination of the technology acceptance model with older consumers", *Journal of Organizational and End User Computing*, 18(3), 2006, pp. 47–65.
- [92] A.V. Citrin, D.E. Spritt, S.N. Silverman, and D.E. Stem, "Adoption of Internet Shopping: The Role of Consumer Innovativeness", *Industrial Management and Data Systems*, 100(7), 2000, pp. 294–300.
- [93] R.E. Goldsmith and C.F. Hofacker, "Measuring Consumer Innovativeness", *Journal of the Academy of Marketing Science*, 19(3), 1991, pp. 209–221.
- [94] R.E. Goldsmith and C.F. Hofacker, "Identifying innovators in consumer product markets", *European Journal of Marketing*, 26(12), 1992, pp. 42–55.
- [95] R.E. Goldsmith, "Using the Domain Specific Innovativeness Scale to identify innovative Internet consumers", *Internet Research*, 11(2), 2001, 149–158.
- [96] R.E. Goldsmith, F. d'Hauteville, and L.R. Flynn, "Theory and measurement of consumer innovativeness: a transnational evaluation", *European Journal of Marketing*, 32(3–4), 1998, pp. 340–353.

Research article 2

Merikivi, J. (2009)

What Habbo Goers Do in Practice? Decomposing Attitudinal Beliefs, In *the proceedings of the 17th European Conference on Information Systems*, Verona, Italy, 8.-10.6.2009.

Reprinted with permission from the Association for Information Systems.

1-1-2009

What Habbo Goers Do in Practice? Decomposing Attitudinal Beliefs.

Jani Merikivi

Turku Centre for Computer Science, jani.merikivi@tse.fi

Follow this and additional works at: <http://aisel.aisnet.org/ecis2009>

Recommended Citation

Merikivi, Jani, "What Habbo Goers Do in Practice? Decomposing Attitudinal Beliefs." (2009). *ECIS 2009 Proceedings*. Paper 86.
<http://aisel.aisnet.org/ecis2009/86>

This material is brought to you by the European Conference on Information Systems (ECIS) at AIS Electronic Library (AISeL). It has been accepted for inclusion in ECIS 2009 Proceedings by an authorized administrator of AIS Electronic Library (AISeL). For more information, please contact elibrary@aisnet.org.

WHAT HABBO GOERS DO IN PRACTICE? DECOMPOSING ATTITUDINAL BELIEFS

Jani Merikivi, Turku Centre for Computer Science, 20520 Turku, Finland,
jani.merikivi@tse.fi

The popularity of social virtual worlds (SVWs) stems from the proficiency of designing appealing activities. In a volitional use context, hedonic outcomes, such as pleasure and enjoyment, along with social interactivity are fundamental attitudinal beliefs fostering the success of SVW. As such, the attitudinal beliefs affecting attitude toward using SVWs with multiple functions is worth studying. The practitioners should however focus on the actual behavioural success factors beyond using SVWs. Using Habbo as an example, this study paper develops a research framework and examines how attitude toward using SVWs mediates Habbo goers' attitudinal beliefs on the actual behavioural incentives. Based on a review of prior literature a decomposed theory of planned behaviour suggested by Taylor and Todd (1995) is employed. The research model is tested with data collected from 1225 active Habbo goers. The main findings of the study suggest that while the Habbo goers desire for social interaction within Habbo the construct of attitude toward using the service fails to reflect it. This indicates that following the omission of discovering the proper attitudinal beliefs behind the actual behavioural factors investments may well be lost.

Keywords: Social Virtual world, Decomposed Theory of Planned Behaviour, Continuous Use, Attitude

1 INTRODUCTION AND BACKGROUND

Social virtual worlds, such as Habbo, Club Penguin, Teen Second Life, Precious Girls Club, and Poptropica, are analytically separable from game worlds which offer the users an opportunity to contend with each other adherence to a set of rules (cf. Bartle, 2004). While possibly including games for pastime SVWs may be described as simulating the physical space of everyday existence, not entirely conjured up by one's imagination. SVWs are practically persistent environments with no specific narrative goal structures congruent with games. These social environments are attracting an enormous group of people sharing somewhat common interest, that is, a need for social interaction (see Fetscherin & Lattemann, 2008). In comparison to virtual communities which are largely designed for communication, SVWs, for example, serve as a technological tool to make videos or design clothes, and contain graphic elements such as avatars in either two or three dimensional virtual environment in order to create an immersive experience.

From users' perspective, successful SVWs aimed particularly at the young perform multiple functions. What these SVWs provide is, however, as individual as the uniqueness of the young themselves. But for nearly every young person they generally are social interaction and gaming. Habbo, for example, is a popular and influential commercial social virtual world among those targeted for preteens and teens aged 10 to 18. It provides a free access to over 30 local portals with several public facilities such as virtual parks, and cafés, and millions of user-generated private virtual rooms. In Habbo, the young Habbo goers are able to communicate with one another and play various non-violent online games. To express themselves the Habbo goers may customise their walking, talking, shouting, and dancing avatars which are representations of themselves or their alter egos, and buy Habbo credits to create and furnish their very own personal virtual rooms. The positive attitude toward participating in free events, running distinct groups, or activities, and creating the content, for example, to honour celebrities has extended beyond the boundaries of the service, motivating them to establish an infinite number of fan sites on the internet (Global Habbo Youth Survey, 2006). Especially the live visits of famous real-life athletes and artists from the music and film industry have endeared Habbo to the young (Global Habbo Youth Survey, 2008). Not building on access fees but commercials, and voluntary premium services Habbo has so far succeeded in holding the critical mass of the young and translated their loyalty directly into monetary value.

The technology acceptance and post-adoption behaviour have attracted prominent and extensive research coverage within IS discipline (Agarwal & Prasad, 1997; Bhattacharjee, 2001; Hsu & Lin, 2008; Karahanna, Straub & Chervany, 1999; Venkatesh & Brown, 2001). Furthermore, prior studies have focused on virtual communities and their unique characteristics through various methods (Bagozzi & Dholakia, 2002; Wellman & Gulia, 1999). Little information is, however, available on expanding the understanding of continued use intention of using SVW with multiple purposes. Consequently, SVWs offer opportunities for testing theories and models in a new context. Hence, for thoroughly grasping the phenomenon regarding the behavioural incentives behind using SVWs calls research in several disciplines such as sociology, economics, and psychology, to mention only a few.

To better complement these existing approaches and to focus more explicitly on examining the conceptualised role of attitudes and the accessible behavioural beliefs behind them, this study exemplifies the theory of planned behaviour (TPB) (Ajzen, 2005). Moreover, agreeing with Shimp and Kavas (1984), who suggest that cognitive constructs of belief cannot be combined to single conceptual determinant, the study expands upon decomposed TPB (Taylor & Todd, 1995; Hsieh, Rai & Keil, 2008) as it provides a comprehensive framework for analysing the information on the antecedents of attitude toward using SVWs. It should, however, be worth noting that behavioural models, such as the theory of reasoned action (TRA) (Fishbein & Ajzen, 1975), the technology acceptance model (TAM) (Davis, Bagozzi & Warshaw, 1989; Davis, 1989) and TPB (Ajzen, 2005)

are constrained to analysing only one behaviour of interest. Applying these theories is rather challenging when examining the use of any technological innovation serving multiple purposes. Consequently, this study is confined here to dealing only with factors regarding attitude toward using SVWs, for which the decomposed TPB is assumed to provide a valuable framework.

In this study, the focus is on Habbo, which is favoured by many active young people because they use it for playing games, trading in virtual furniture, familiarising themselves and communicating with online and offline friends (Global Habbo Youth Survey, 2006; 2008). In other words, meeting with new and old friends and creating, sharing, and consuming the interesting content influenced by norms, values, and offline life is perceived important within such pleasing and enjoyable virtual environment (Bagozzi & Dholakia, 2002; Hagel, 1999). The SVWs have clearly moved beyond mere entertainment into social realm. Therefore, attention is particularly paid on hedonic and social outcomes. Developing the construct of attitude toward use is of major importance, as it may increase the risk of losing information instead of identifying the actual evaluative variables to distinguish in details why exactly SVWs are being used and how the accessible beliefs are linked to them.

As a result, the purpose of this study paper is to develop a framework and examine how the attitude toward using SVWs mediates the impact of Habbo goers' attitudinal beliefs on the underlying actual behavioural interests. This study paper has three primary goals. First, by identifying the actual factors behind using SVWs it should enhance theoretical knowledge of developing behavioural frameworks utilised in other online services as well, and, second, provide better managerially relevant and readily discernible in-depth understanding of true behavioural incentives that are beneficial in designing features and services for SVWs. Thirdly, by examining particularly the existing Habbo goers it accumulates the post-adoption user behaviour research (Limayem & Cheung, 2008; Premkumar & Bhattacharjee, 2008).

2 RESEARCH MODEL

Individuals use information technology from both extrinsic and extrinsic motives (Davis, Bagozzi & Warshav, 1992; Vallerand, 1997), also articulated in consumer behaviour (Venkatraman & MacInnis, 1985) and IS literature on technology acceptance (Hsieh et al. 2008; van der Heijden, 2004; Venkatesh & Brown, 2001). Extrinsic incentive propels individuals for achieving a specific goal, whereas intrinsic, in other words, hedonic is the degree to which users experience pleasure, joy, or satisfaction derived from a specific behaviour (Deci & Ryan, 1980). Teo, Lim, and Lai (1999) have empirically shown that intrinsic incentive has a significant effect on using computer and the internet. In a post-adoption context, users may obtain, at least in part, pleasure through appealing environmental characteristics but more salient is the need for maintaining the concentration and curiosity, as well as satisfying the entertainment purposes (cf. e.g. Ahn, Ryu & Han, 2007; Igbaria, Schiffman & Wieckowski, 1994). For example, the Habbo goers look for a playful job or task inside Habbo in a form of a role play and work as fashion models walking on virtual catwalks. As a result, perceived enjoyment (ENJ) is an emotionally fulfilling activity, and playfulness (PLA), which represents the user's short-term cognitive involvement, are believed to influence attitude toward using SVWs (Woszczynski, Roth & Segars, 2002). It is, thus, postulated that:

H1: Enjoyment (ENJ) positively affects the attitude toward using Habbo.

H2: Playfulness (PLA) positively affects the attitude toward using Habbo.

It is assumed that leisure-oriented post-adoption user behaviour is not driven by strong productivity but rather instrumental value as to effectively communicate and develop social identity (Bagozzi & Dholakia, 2002). In SVWs, the interaction occurs with one another, not between users and the system as mentioned by Heijden (van der Heijden, 2004). The behaviour may still be extrinsic when the purpose of exchanging information or resources through computers is to accomplish tasks, for instance, to express uniqueness. Unfortunately, it may, however, be extremely difficult to differentiate extrinsic from intrinsic behaviour since interaction may as well carry positive or negative emotions not

necessary in achieving external objectives (Yuan & Gay, 2006). Therefore, within this study paper, interaction with one another implies to social outcomes such as social connectedness (CON), self-exploration (UNI), and status (STA), indicating that these three concepts should be distinguished from intrinsic and extrinsic, and discussed separately.

The Habbo goers have an access to a virtual network that facilitates the exchange of social closeness and status. The need for belongingness reflects subjective awareness of interpersonal closeness (Lee & Robbins, 1995; Lee & Robbins, 1998). Therefore, social connectedness particularly relates to self-fulfilling emotional outcomes such as affiliation and support in bringing individuals together both in offline and online (Baumeister & Leary, 1995; Chiu, Hsu & Wang, 2006; Rheingold, 2000; Wellman & Gulia, 1999). As a result, it is hypothesised, that:

H3: Connectedness (CON) positively affects the attitude toward using Habbo.

Social status pertains to the probable instrumental value and is, therefore, conferred on individuals as a result of adopting a technological innovation (Moore & Benbasat, 1991; Venkatesh & Brown, 2001; Venkatesh & Davis, 2000). In SVWs, through participation individuals are volitionally pursuing to gain the esteem, in which others hold them. The relative position of individuals in SVWs is closely linked to the need for uniqueness in differentiating themselves from others through consumption of virtual items (cf. e.g. Ruvio, 2008; Snyder & Fromkin, 1977; Tian, 2001). In Habbo, to appeal the users' desire for uniqueness Habbo goers are able to express their true or idealised identity via acquiring and possessing products such as avatars and virtual furniture that are not recognised as being outside of the norm. To encourage the Habbo goers to purchase and possess new and vintage virtual furniture it is designed to convey product-scarcity, uniqueness, and nonconformity. On the other hand, the Habbo goers exploit the opportunity to use avatars reflecting their offline appearance, expressing sometimes provoking messages, or releasing themselves from offline social norms (Vasalou, Joinson, Bänziger, Goldie & Pitt, 2008). For empowering the Habbo goers to seek status and uniqueness it is hypothesised that:

H4: Self-exploration (UNI) positively affects the attitude toward using Habbo.

H5: Status (STA) positively affects the attitude toward using Habbo.

In SVWs, where individuals are geographically separated and it is literally impossible to touch one another, they share the illusion of being physically in the same virtual environment in the guise of fictional characters conveying and embodying real-time socio-emotional behaviour such as movements and facial expressions (Bente, 2008; Bailenson, 2005). The feeling of closeness of another individual refers to the concept of social presence (PRE) in a mediated interaction (Biocca, Harms & Burgoon, 2003; Rice & Love, 1987; Short, 1976). If the shared virtual environment and the existence of avatars enable the users to experience non-verbal cues, they both facilitate the experience of social presence in virtual encounters and strengthen the positive evaluation of using Habbo. Therefore, it is postulated that:

H6: Social presence (PRE) affects positively toward using Habbo.

Development of the scales to measure the evaluation summary of attitude toward behaviour of interest is generated based on the suggestions of Ajzen (2005). The construct of attitude is the degree to which using Habbo is valued. In order to investigate the suitability of the construct of attitude used in prior IS literature (e.g. Hsieh et al., 2008; Karahanna et al., 1999) and its ability to mediate behavioural beliefs and the behavioural goals in the context of SVWs with multiple functions, items measuring the most popular underlying and actual prevailing behaviour, such as attitude toward playing games (GAM), trading in furniture (TRA), and becoming friends (SOC) were grounded on the empirical studies (Global Habbo Youth Survey, 2006; 2008). The construct of attitude should thus reflect the evaluation of performing the actual behaviour of interest since it would be challenging to specify every action beyond using technologies with multiple functions. The attitude of construct must therefore be accordingly determined. As a result, the following hypotheses are proposed:

H7: Attitude toward using Habbo mediates the actual willingness to social interaction with one another.

H8: Attitude toward using Habbo mediates the actual willingness to collect virtual furniture.

H9: Attitude toward using Habbo mediates the actual willingness to play games within Habbo.

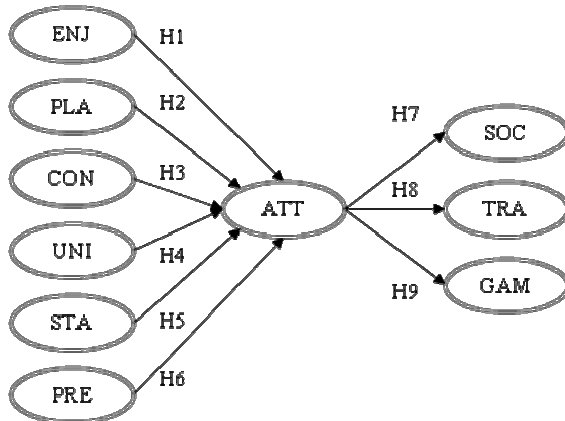

Figure 1. Research model

3 EMPIRICAL RESEARCH

3.1 Research design and data collection

First, to explain the key factors why Habbo is actually being used the attitudinal beliefs were drawn from prior literature. Second, the research model was developed on the basis of TPB and the constructs as represented in IS research with one exception: those constructs founded on the key factors indicating the actual behaviour beyond using SVWs were formed using exploratory factor analysis (EFA). After the key factors were found, pilot study was conducted prior to the primary data collection. Finally, the goal of the empirical part of the study was to validate and test the research model (Figure 1) with confirmatory factor analysis (CFA), and investigate causal relationships between the latent variables.

The actual online survey instrument was built, and, in July 2008, the quantitative data from the users of Habbo Finland was collected. The survey was available approximately for a week and it contained worded items which respondents had to evaluate on a 7-point Likert-scale adapted from existing measures. To receive only one response from a single respondent a reward of any kind was not offered to the respondents (O'Neill & Penrod, 2001). In addition, multiple submissions were software-disallowed by excluding any responses from the same computer. The results reported here, are the responses of those willing to participate. That is to say, those Habbo goers who were the focus of the study were able to reach out.

A total of 3265 usable responses were received. To ensure the best possible quality of the responses, only fully completed responses were totally included in the analysis. After excluding cases with missing or incomplete responses 1225 fully completed and usable cases were retained for the analysis. Large drop of valuable responses was due to a long survey. 94 % of the respondents were between 10 and 18 years old.

To test the applicability of the research model AMOS 16.0.1, the maximum likelihood estimation method was applied here since it has been considered robust against the moderate violation of

multivariate normality with sample sizes exceeding 100 cases (Muthén & Kaplan, 1985; Steenkamp & van Trijp, 1991). The distortion of chi-squares and standard errors is likely if most of the skewness and/or kurtosis are larger in absolute value than 2.0, and the correlations are 0.5 or higher. According to Bollen (1989), all normal distribution estimations methods, including maximum likelihood, are consistent even if the assumption of normality is moderately violated. The test for normality showed that the skewness of only a few observed variables was higher than 2.0, thus, implying that the data is moderately non-normal, and therefore maximum likelihood would be an appropriate and robust estimation method. Asymptotical distribution free is suggested as superior to maximum likelihood only when the observed variables have an average univariate kurtosis larger than three and the sample size greater than 400 (Hoogland & Boomsma, 1998). The assessment of normality showed that every univariate kurtosis was below three.

3.2 Measurement Model and Results

The adapted constructs of the research model were evaluated by examining internal consistency and convergent validity. To do this, the item-construct-loading, composite reliability, and average value extracted (AVE) were assessed. As regards item reliability, item loadings exceed 0.707 (Agarwal & Karahanna, 2000), the composite reliabilities 0.707 (Nunnally, 1978) and AVE values 0.50 (Fornell & Larcker, 1981). The information on the loadings of the measures used in the research model, descriptive statistics, and the reliability of the constructs are represented in table 1. The results showed that all reflective measures fulfilled the recommended levels of composite reliability and average variance extracted.

Construct	Loading	Composite Reliability	AVE
ENJ1	0.909	0.953	0.723
ENJ2	0.958		
ENJ3	0.933		
PLA1	0.869	0.842	0.593
PLA2	0.837		
CON1	0.813	0.841	0.592
CON2	0.889		
UNI1	0.907	0.953	0.769
UNI2	0.923		
UNI3	0.902		
UNI4	0.921		
STA1	0.888	0.893	0.618
STA2	0.909		
PRE1	0.872	0.859	0.601
PRE2	0.864		
ATT1	0.915	0.936	0.713
ATT2	0.906		
ATT3	0.910		
SOC1	0.818	0.851	0.597
SOC2	0.902		
TRA1	0.935	0.943	0.641
TRA2	0.954		
GAM1	0.778	0.785	0.564
GAM2	0.829		

Table 1. Loadings, Composite Reliability, and AVE

Discriminant validity was investigated by examining whether the AVE was higher than the squared correlation for each construct (Fornell & Larcker, 1981). The correlations provided clear evidence that the relationship among all constructs were below the AVE in question (Table 2). Model fit indices address (GFI=.921, TLI=.954; NFI=.953, CFI=.962, and RMSEA=.058) that the proposed model was acceptable with the exception that AGFI (0.896) went slightly below the recommended threshold (see (Gefen, Straub & Boudreau, 2000).

	GAM	SOC	TRA	ATT	ENJ	PLA	CON	STA	PRE	UNI
GAM	0.564									
SOC	0.047	0.597								
TRA	0.036	0.036	0.641							
ATT	0.224	0.209	0.160	0.713						
ENJ	0.113	0.105	0.081	0.503	0.723					
PLA	0.088	0.082	0.063	0.393	0.637	0.593				
CON	0.000	0.000	0.000	0.002	0.010	0.002	0.592			
STA	0.034	0.032	0.025	0.154	0.206	0.416	0.098	0.618		
PRE	0.076	0.070	0.054	0.336	0.504	0.490	0.011	0.274	0.601	
UNI	0.017	0.016	0.012	0.077	0.103	0.205	0.061	0.249	0.158	0.769

Table 2. Squared pairwise correlations and assessment of discrimination validity

In total, the results support six of the nine hypotheses. Contrary to initial postulations, connectedness (CON), self-exploration (UNI), and status (STA) had no significant effect on attitude (ATT). Playing games (PLA) (0.13) alongside social presence (PRE) (0.12), a noteworthy exception of those measures associated with social outcomes, had only a moderate impact on ATT, whereas ENJ (0.52) had the strongest influence, a finding consistent with past research. On the other hand, the path coefficients from ATT to becoming friends (SOC) (0.46), trading in furniture (TRA) (0.40), and GAM (0.47) were statistically significant and interpretable if only somewhat surprising, given that the strength of paths from CON, UNI, and STA were statistically insignificant. The attitudinal constructs examined within this study paper explained 52 percent of the variance in the Habbo goers' evaluation of using the service. ATT, for one, explained 21 percent (SOC), 16 percent (TRA), and 22 percent (GAM) of the variance in Habbo goers' actual behavioural incentives. Figure 2 represents the path coefficients and the squared multiple correlations.

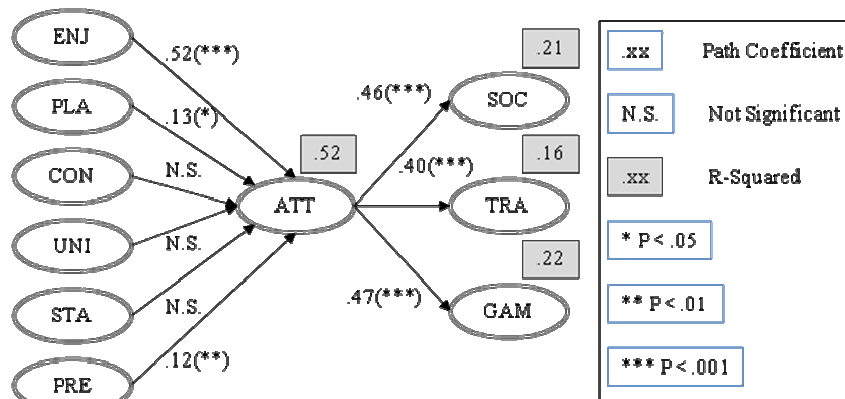

Figure 2. Structural Model

4 DISCUSSION

4.1 Findings

The results showed that 52 percent of the variance in the Habbo goers' evaluation of using Habbo attitude (ATT) was shaped by enjoyment (ENJ), playfulness (PLA), and social presence (PRE), indicating that those social outcomes, such as connectedness (CON), self-exploration (UNI), and status (STA), had no significant influence on attitude. However, a post hoc analysis revealed that when paths from connectedness, self-exploration, and status were directly connected to becoming friends (SOC), trading in furniture (TRA), and playing games (GAM), the actual behavioural incentives beyond use were better explained. Thus, in the context of SVWs with multiple functions aimed particularly at the young, the users are not only craving for pleasure but social interaction with one another. These findings are in line with empirical evidence presented in prior literature examining virtual communities (Bagozzi & Dholakia, 2002; Rheingold, 2000; Wellman & Gulia, 1999) and leisure oriented technologies (van der Heijden, 2004). Taken as a whole, the users who volitionally have engaged with SVWs are especially driven by enjoyable social activities, such as playing games, collecting virtual items, and becoming friends with other users.

4.2 Implications for theory and practice

Empirical evidence on how both hedonic and social outcomes can be included in a research model adapted to virtual worlds, has been somewhat an open question. This study paper examines this issue by demonstrating, that among the experienced young users, hedonic and social aspects are pivotal factors for successful hedonic information systems. Contrary to prior studies that focus on social influence (i.e. social pressure to perform behaviour), this study has introduced the lack of a sophisticated attitudinal construct that measures the need for social interaction (cf. e.g. the distinct between playing video games alone or with other individuals). Therefore, the represented research model expands upon the current continued use model by underscoring the user's need for enjoyable experiences and social interaction, postulating a direct path between them and the attitude toward continued use of SVWs. First, by identifying the actual key factors behind using SVWs the study enhances theoretical knowledge of developing behavioural frameworks built upon the IS research. Second, since practitioners are responsible for designing attracting virtual environments, the study has focused on providing better managerially relevant in-depth understanding of true behavioural incentives that contributes to the building of user commitment. The results suggest that managers should not concentrate only on the technology use but the actual reasons why it is being used. When adding or removing features it is important to be aware how attitudinal beliefs affect the actual behavioural incentives. Thirdly, by particularly examining the experienced Habbo goers the study accumulates the post-adoption user behaviour research (e.g. Limayem & Cheung, 2008; Premkumar & Bhattacharjee, 2008).

To develop a robust research model for examining the use behaviour, it is likely that the items related to the attitude toward using SVWs must cover the social aspect as well. Since only a few, if any, studies that focus on developing behavioural constructs to measure the use of SVWs exist, this study paper offers a theoretical implication for IS research.

4.3 Limitations and future research

Employing IS theories is rather challenging when examining the use of any technological innovation serving multiple purposes. Consequently investigating SVWs is confined to dealing only with factors regarding attitude toward using SVWs, determined by the individual's assessment of the outcomes associated with the behaviour (Ajzen, 2005). Determinants such as subjective norms and perceived behavioural control have been deliberately omitted. The future research is, thus, required to examine how subjective norms, and perceived behavioural control, in addition to attitude, affect continued use intention in the context of SVWs. Furthermore, large drop of valuable responses due to a long survey

may have limited the accuracy of the results. Also, generalising these results into context other than SVWs should be handled with care. It is proposed to take into account that the results depend on respondents' subjective assessment (see Straub & Limayem, 1995) and their socio-cultural backgrounds that may have a significant impact on usage behaviour. This is of great importance especially when the service is globally available. Finally, this study represents a cross-section of behavioural incentives beyond using SVWs. When the appropriate measures are discovered longitudinal study examining post adoption behaviour may provide better understanding of the users' behaviour, their motivation, and their intentions.

5 CONCLUSIONS

Providers of SVWs should focus on the actual behavioural incentives beyond using the technology. Creating interactive and hedonic services to the young is a fundamental goal which is virtually as central as the technical characteristics of SVWs. The present study paper exemplifies a decomposed theory of planned behaviour in order to represent an important step toward examining and developing the construct of attitude toward using SVWs with multiple functions aimed at the young. Most importantly, using Habbo as an example, study paper empirically demonstrates how TPB-grounded research model explains a significant amount of variance in the Habbo goers' evaluation of using SVWs but, at the same time, relegates the social aspects into the background. The findings indicate that, in the context of SVWs, the construct of attitude toward using the technology, must include items related to social outcomes together with hedonic outcomes.

ACKNOWLEDGEMENTS

I would like to state my gratitude to Finnish Youth Research Society, Foundation for Economic Education, and Sulake Corporation for assistance in conducting this study, as well as Jussi Puhakainen, Tommi Hoikkala, Mikko Ketokivi, and Matti Mäntymäki.

References

- Agarwal, R. and Karahanna, E. (2000). Time Flies when You're having Fun: Cognitive Absorption and Beliefs about Information Technology Usage. *MIS Quarterly*, 24 (4), 665-694.
- Agarwal, R. and Prasad, J. (1997). The role of innovation characteristics and perceived voluntariness in the acceptance of information technologies. *Decision Sciences*, 28 (3), 557-582.
- Ahn, T., Ryu, S. and Han, I. (2007). The impact of Web quality and playfulness on user acceptance of online retailing. *Information & Management*, 44 (3), 263-275.
- Ajzen, I. (2005). Attitudes, personality, and behavior. 2nd Edition. Open University Press, Maidenhead.
- Bagozzi, R.P. and Dholakia, U.M. (2002). Intentional social action in virtual communities. *Journal of Interactive Marketing*, 16 (2), 2-21.
- Bailenson, J.N. (2005). Transformed Social Interaction, Augmented Gaze, and Social Influence in Immersive Virtual Environments. *Human Communication Research*, 31 (4), 511-537.
- Bartle, R.A. (2004). Designing virtual worlds. New Riders, Indianapolis, Ind.
- Baumeister, R.F. and Leary, M.R. (1995). The need to belong: Desire for interpersonal attachments as a fundamental human motivation. *Psychological Bulletin*, 117 (3), 497-529.
- Bente, G. (2008). Avatar-Mediated Networking: Increasing Social Presence and Interpersonal Trust in Net-Based Collaborations. *Human Communication Research*, 34 (2), 287-318.
- Bhattacharjee, A. (2001). An empirical analysis of the antecedents of electronic commerce service continuance. *Decision Support Systems*, 32 (2), 201-214.

- Biocca, F., Harms, C. and Burgoon, J.K. (2003). Toward a More Robust Theory and Measure of Social Presence: Review and Suggested Criteria. *Presence: Teleoperators and Virtual Environments*, 12 (5), 456-480.
- Bollen, K.A. (1989). *Structural Equations with Latent Variables*. John Wiley & Sons, New York, NY.
- Chiu, C., Hsu, M. and Wang, E.T.G. (2006). Understanding knowledge sharing in virtual communities: An integration of social capital and social cognitive theories. *Decision Support Systems*, 42 (3), 1872-1888.
- Davis, F.D. (1989). Perceived Usefulness, Perceived Ease of Use, and User Acceptance of Information Technology. *MIS Quarterly*, 13 (3), 319-340.
- Davis, F.D., Bagozzi, R.P. and Warshaw, P.R. (1989). User Acceptance of Computer Technology: A Comparison of Two Theoretical Models. *Management Science*, 35 (8), 982-1003.
- Davis, F.D., Bagozzi, R.P. and Warshaw, P.R. (1992). Extrinsic and Intrinsic Motivation to Use Computers in the Workplace. *Journal of Applied Social Psychology*, 22 (14), 1111-1132.
- Deci, E.L. and Ryan, R.M. (1980). The Empirical Exploration of Intrinsic Motivational Processes. In: Berkowitz, L. (Ed.), *Advances in Experimental Social Psychology*. p. 39-80, Academic Press, New York, NY.
- Fetscherin, M. and Lattemann, C. (2008). User acceptance of virtual worlds. *Journal of Electronic Commerce Research*, 9 (3), 231-242.
- Fishbein, M. and I. Ajzen (1975). *Belief, Attitude, Intention, and Behavior: An introduction to the Theory and Research*. Addison-Wesley, Reading, MA.
- Fornell, C. and Larcker, D.F. (1981). Evaluating structural equation models with unobservable variables and measurement error. *Journal of Marketing Research*, 18 (1), 39-50.
- Gefen, D., Straub, D.W. and Boudreau, M. (2000). Structural Equation Modeling and Regression: Guidelines for Research Practice. *CAIS*, 4 (7), 1-78.
- Ghani, J.A. and Deshpande, S.P. (1994). Task characteristics and the experience of optimal flow in human-computer interaction. *Journal of Psychology*, 128 (4), 381-391.
- Global Habbo Youth Survey (2006). *Global Habbo Youth Survey – Fall 2006*. 15/30 Research, Helsinki.
- Global Habbo Youth Survey (2008). *Global Habbo Youth Survey 2008*. 15/30 Research, Helsinki.
- Hagel, J.I. (1999). Net gain: Expanding markets through virtual communities. *Journal of Interactive Marketing*, 13 (1), 55-66.
- Hoogland, J.J. and Boomsma, A. (1998). Robustness Studies in Covariance Structure Modeling. *Sociological Methods & Research*, 26 (3), 329-367.
- Hsieh, J.J.P., Rai, A. and Keil, M. (2008). Understanding Digital Inequality: Comparing Continued Use Behavioral Models of the Socio-Economically Advantaged and Disadvantaged. *MIS Quarterly*, 32 (1), 97-126.
- Hsu, C. and Lin, J.C. (2008). Acceptance of blog usage: The roles of technology acceptance, social influence and knowledge sharing motivation. *Information & Management*, 45 (1), 65-74.
- Igbaria, M., Schiffman, S.J. and Wieckowski, T.J. (1994). The respective roles of perceived usefulness and perceived fun in the acceptance of microcomputer technology. *Behaviour & Information Technology*, 17 (6), 349-361.
- Karahanna, E., Straub, D.W. and Chervany, N.L. (1999). Information Technology Adoption Across Time: A Cross-sectional Comparison of Pre-adoption and Post-adoption Beliefs. *MIS Quarterly*, 23 (2), 183-213.
- Koufaris, M. (2002). Applying the technology acceptance model and flow theory to online consumer behavior. *Information Systems Research*, 13 (2), 205-223.
- Koufaris, M., Kambil, A. and Labarbera, P.A. (2001). Consumer Behavior in Web-Based Commerce: An Empirical Study. *International Journal of Electronic Commerce*, 6 (2), 115-138.
- Lee, R.M. and Robbins, S.B. (1995). Measuring belongingness: The social connectedness and the social assurance scales. *Journal of Counseling Psychology*, 42 (2), 232-241.
- Lee, R.M. and Robbins, S.B. (1998). The relationship between social connectedness and anxiety, self-esteem, and social identity. *Journal of Counseling Psychology*, 45 (3), 338-345.

- Limayem, M. and Cheung, C.M.K. (2008). Understanding information systems continuance: The case of Internet-based learning technologies. *Information & Management*, 45 (4), 227-232.
- Moore, G.C. and Benbasat, I. (1991). Development of an Instrument to Measure the Perceptions of Adopting an Information Technology Innovation. *Information Systems Research*, 2 (3), 192-222.
- Muthén, B.O. and Kaplan, D. (1985). A comparison of some methodologies for the factor analysis of non-normal Likert variables. *British Journal of Mathematical and Statistical Psychology*, 38 (2), 171-189.
- Nunnally, J.C. (1978). *Psychometric Theory*. 2nd Edition. McGraw-Hill, New York.
- O'Neill, K.M. and Penrod, S.D. (2001). Methodological variables in Web-based research that may affect results: Sample type, monetary incentives, and personal information. *Behavior Research Methods, Instruments, & Computers*, 33 (2), 226-233.
- Premkumar, G. and Bhattacharjee, A. (2008). Explaining information technology usage: A test of competing models. *Omega*, 36 (1), 64-75.
- Rheingold, H. (2000). *The Virtual Community: Homesteading on the Electronic Frontier*. MIT Press, Cambridge, MA.
- Rice, R.E. and Love, G. (1987). Electronic Emotion: Socioemotional Content in a Computer-Mediated Communication Network. *Communication Research*, 14 (1), 85-108.
- Ruvio, A. (2008). Consumers' need for uniqueness: short-form scale development and cross-cultural validation. *International Marketing Review*, 25 (1), 33-53.
- Shimp, T.A. and Kavas, A. (1984). The Theory of Reasoned Action Applied to Coupon Usage. *Journal of Consumer Research*, 11 (3), 795-809.
- Short, J. (1976). *The social psychology of telecommunications*. John Wiley & Sons, London.
- Snyder, C.R. and Fromkin, H.L. (1977). Abnormality as a positive characteristic: The development and validation of a scale measuring need for uniqueness. *Journal of Abnormal Psychology*, 86 (5), 518-527.
- Steenkamp, J.E.M. and van Trijp, Hans C. M. (1991). The use of LISREL in validating marketing constructs. *International Journal of Research in Marketing*, 8 (4), 283-299.
- Straub, D. and Limayem, M. (1995). Measuring System Usage: Implications for IS Theory Testing. *Management Science*, 41 (8), 1328-1343.
- Taylor, S. and Todd, P. (1995). Decomposition and crossover effects in the theory of planned behavior: A study of consumer adoption intentions. *International Journal of Research in Marketing*, 12 (2), 137-155.
- Teo, T.S.H., Lim, V.K.G. and Lai, R.Y.C. (1999). Intrinsic and extrinsic motivation in Internet usage. *Omega*, 27 (1), 25-37.
- Tian, K.T. (2001). Consumers' Need for Uniqueness: Scale Development and Validation. *Journal of Consumer Research*, 28 (1), 50-66.
- Vallerand, R.J. (1997). Toward a Hierarchical Model of Intrinsic and Extrinsic Motivation. In: Zanna, M.P. (Ed.), p. 271-360. Academic Press, New York.
- van der Heijden, H. (2004). User Acceptance of Hedonic Information Systems. *MIS Quarterly*, 28 (4), 695-704.
- Vasalou, A., Joinson, A., Bänziger, T., Goldie, P. and Pitt, J. (2008). Avatars in social media: Balancing accuracy, playfulness and embodied messages. *International Journal of Human-Computer Studies*, 66 (11), 801-811.
- Venkatesh, V. and Brown, S.A. (2001). A Longitudinal Investigation of Personal Computers in Homes: Adoption Determinants and Emerging Challenges. *MIS Quarterly*, 25 (1), 71-102.
- Venkatesh, V. and Davis, F.D. (2000). A Theoretical Extension of the Technology Acceptance Model: Four Longitudinal Field Studies. *Management Science*, 46 (2), 186-204.
- Venkatraman, M.P. and MacInnis, D.J. (1985). The Epistemic and Sensory Exploratory Behaviors of Hedonic and Cognitive Consumers. In: Hirschman, E.C. and M.B. Holbrook (Eds.), *Advances in Consumer Research*. p. 102-107, Association for Consumer Research, Provo, UT.
- Wellman, B. and Gulia, M. (1999). Net-Surfers Don't Ride Alone: Virtual Communities as Communities. In: Smith, M.A. and P. Kollock (Eds.), *Communities in Cyberspace*. Routledge, New York.

Woszczynski, A.B., Roth, P.L. and Segars, A.H. (2002). Exploring the theoretical foundations of playfulness in computer interactions. *Computers in Human Behavior*, 18 (4), 369-388.

Yuan, Y.C. and Gay, G. (2006). Homophily of Network Ties and Bonding and Bridging Social Capital in Computer-Mediated Distributed Teams. *Journal of Computer-Mediated Communication*, 11 (4), 1062-1084.

APPENDIX 1

Construct	Measurement Item (on a 7-point Likert-scale)	Source
ATT1	Extremely displeasing...pleasing	Karahanna et al., 1999; Ajzen, 2005)
ATT2	Extremely frustrating...easy; a great pleasure to use	
ATT3	Extremely terrible...delightful	
SOC1	I like getting to know new people	Global Habbo Youth Survey 2006; 2008
SOC2	I like making friends with other Habbo users	
TRA1	I like collecting rare furniture	
TRA2	I like collecting valuable furniture	
GAM1	I like organising and playing games as well as participating in competitions	
GAM2	I like playing games	
UNI1	I actively seek to develop my personal uniqueness by using special products or brands	Ruvio, 2008; Snyder & Fromkin, 1977; Tian, 2001
UNI2	Having an eye for products that are interesting and unusual assist me in establishing a distinctive image	
UNI3	The products and the brand I like the best are the ones that express my individuality	
UNI4	I am often on the lookout for new products or brands that will add to my personal uniqueness	
ENJ1	It is fun to use Habbo	Venkatesh & Brown, 2001; Davis et al. 1992; van der Heijden, 2004
ENJ2	It is entertaining to use Habbo	
ENJ3	It is pleasant to use Habbo	
PRE1	There is a sense of sociability in Habbo (users are companionable)	Short, 1976
PRE2	There is a sense of human warmth in Habbo	
STA1	Using Habbo improves my status among those who are richest and smartest	Venkatesh & Brown, 2001
STA2	Using Habbo improves my status among those who are the most meaningful to me	
CON1	I feel so distant from others in Habbo	Lee & Robbins, 1995; Lee & Robbins, 1998
CON2	I have no feeling of togetherness with others in Habbo	
PLA1	Using Habbo increases my interest in exploring things	Ghani & Deshpande, 1994; Koufaris, Kambil & Labarbera, 2001; Koufaris, 2002
PLA2	Using Habbo arouses my imagination	

Research article 3

**Mäntymäki, M. – Merikivi, J. – Verhagen, T. – Feldberg, F. – Rajala, R.
(in review)**

Still there? Understanding the continued use of virtual worlds.

Unpublished manuscript.

Still there? Understanding the continued use of virtual worlds

Matti Mäntymäki^{a*}, Jani Merikivi^a, Tibert Verhagen^b, Frans Feldberg^b, Risto Rajala^c

^aTurku School of Economics, University of Turku
Rehtorinpellonkatu 3
20520 Turku
Finland
matti.mantymaki@utu.fi; jani.merikivi@utu.fi

^bVU University Amsterdam, Faculty of Economics and Business Administration
De Boelelaan 1105
1081 HV Amsterdam
The Netherlands
t.verhagen@vu.nl; j.f.m.feldberg@vu.nl

^cAalto University, School of Economics
Runeberginkatu 14-16
00100 Helsinki
Finland
risto.rajala@aalto.fi

Abstract

The increasing competition among virtual worlds calls for well-grounded decisions that foster continuous user engagement and intentions to return. This study analyzes the determinants of users' intention to continue engaging with virtual worlds by integrating the theory of planned behavior and three auxiliary theories. We demonstrate the need for a theory-based disaggregation of the constructs underlying the sustained intent to use virtual worlds. By analyzing primary data collected from 921 users of Habbo Hotel, the largest virtual world for teenagers, this study corroborates user's intrinsic motivation, interpersonal influence and self-efficacy as key constructs of continued virtual-world use. The theoretical implications of the study include demonstrating the usefulness of the decomposed theory of planned behavior in explaining the variance in users' continuous-use intentions in virtual worlds. The implications for practice include recommendations to focus on key areas in where virtual world operators need to make crucial decisions in their pursuance to retain existing users. Finally, limitations and avenues for future research are discussed.

* Corresponding author. Tel. + 358 50 486 7657; Fax. +358 2 241 0154.

Keywords: virtual worlds, continued use, decomposed theory of planned behavior, self-determination, innovation diffusion, social cognition.

1 Introduction

Virtual worlds (VWs) represent a rapidly emerging socio-technical reality for an increasing number of users. As of May 2012, VWs have received 1.9 billion registered users, 60% of which are between 5 and 15 years old [54]. In 2011 alone, Habbo Hotel—the largest VW for teenagers—had an influx of tens of millions of new users, with the total registered users ultimately exceeding 273 million by August 2012 [74]. However, VW operators need to understand users' motivational behavior in order to make decisions that can transform an upswing in initial acceptance into continuous use, which is a key to VW's sustainability and productivity [11]. Given the fierce competitive pressure among VW operators, achieving such a goal is far from self-evident. Hence, understanding how to retain existing users [39,60] has become an important area of VW research.

In the literature, VWs are defined as persistent computer-simulated environments in which multiple users interact simultaneously through avatars [6]. We suggest that an understanding of the elements that drive users' intentions to use VWs on a continued basis demands that diverse attitudinal beliefs, social influences, and system controllability be taken into account. Three characteristics of VWs support this proposition. First, VWs embody a variety of real-time hedonic and utilitarian functions and a ceaseless stream of activities that tap into the extrinsic and intrinsic beliefs underlying people's attitude toward using these systems [80]. Second, when employing VWs for one of their multiple purposes, users do so through interaction with a changeable cast of other people [17]. Therefore, we suggest that social influence [42]—both within and beyond a VW— affects user behavior in VWs. Third, VWs often feature simultaneous events that are to be navigated through an avatar. Bearing this in mind, it is reasonable to suggest that VW-use requires specific skills and a patient learning effort [38] to be able to maintain control over one's own activity in the system.

Although recent studies have provided new and valuable insights into the diverse mechanisms that are unique to the use of VWs [39,68], little effort has been made to combine them into one theoretical structure that would explain the variance in users' intentions to continue using VWs. Addressing this

gap and responding to the calls for research into other VW-relevant characteristics [69], we aim to establish a model that integrates attitudinal beliefs, social influences, and system controllability, and investigate their effects on the continued use intention of VWs¹.

For this purpose, we adopt the decomposed theory of planned behavior (DTPB) [76,77] over other information systems (IS) theories [11] because it allows us to pursue a theory-based decomposition of the three previously mentioned structures. The DTPB is complemented with self-determination theory (SDT) [26], innovation diffusion theory (IDT) [67] and social cognitive theory (SCT) [7]. The SDT is used to capture the motivational behaviors concerning VW use, whereas the IDT guides us in our search for social influences that shape VW users' behavioral intentions. Finally, the SCT takes the effects of system controllability into account.

The objective of this study translates into the following research question: How and to what extent do attitudinal beliefs, social influences, and system controllability predict users' intentions to remain engaged in VWs? By addressing this question through an empirical analysis of data gathered from the largest VW for teenagers, Habbo Hotel, we intend to make three principal contributions.

First, we provide insights into the roles and relative influences of attitudinal beliefs, social influences, and system controllability as the antecedents of continued VW use. The selection and combination of these determinants of continued VW use is appealing as they represent elements that are considered of particular relevance in VW settings yet have received little attention in the post-adoption studies of VWs thus far. Second, pertaining to the more theoretical sphere, we provide insights into the applicability of the DTPB in explaining users' behavior in the VW setting. Such contextual extension should not only demonstrate the robustness of the DTPB as an overarching framework, but also provide indications of the predictive value of the different theoretical perspectives integrated into DTPB. Given that this theoretical lens has been applied in relatively few studies in the IS literature [46] with regard to the continued use of information technology (IT) [52,53] in general, and VWs in particular, these findings are assumed to be of interest to the IS research community in its broadest

¹ Based on Fishbein and Ajzen's [33] conceptualization, we adopt behavioral intention as a proxy for measuring actual behavior, and define it as users' intent to continue using a virtual world, which exemplifies instance of use.

sense. Finally, our results aim to serve the designers, developers, and operators of VWs. The insights into the relative influence of the examined constructs will support VW operators and other business practitioners in their decision-making regarding their investments in VWs.

The paper is structured as follows. We first discuss the theoretical background of our study by characterizing users' post-adoption behavior in VWs and introducing the key concepts and theoretical underpinnings of the DTPB. In the second section, we elaborate upon how we adapt the theory to our research setting by decomposing the key constructs of the DTPB into VW-specific constructs and introduce our research model and hypotheses. We then present our research design, measures, data analysis, and the results of our empirical study. Finally, we conclude the paper by discussing the implications of our findings for both research and in practice.

2 Research background

To choose the relevant theoretical explanations to predict continued VW use, as well as support the selection of viable constructs to measure it empirically, we conducted a context-centric review of the existing body of research literature relating to users' post-adoption behavior in VWs. The results of the review, a pool of six empirical studies, are summarized in Table 1.

Table 1. An overview of post-adoption studies of virtual worlds

Focus	Theoretical background	Key constructs	Target group	Author(s)
VW assimilation as a predictor of continued usage	Theory of reasoned action	Attitude, ease of use, playfulness, social presence, self-distraction	University students	[69]
Continuous VW use and purchasing behavior	Technology acceptance model	Perceived enjoyment, usefulness, network pressure	Adolescents	[60]
Environmental characteristics of VWs and deep user involvement	Interactionist theory of place attachment	Cognitive absorption	University students	[39]
Continuous VW use in the work setting	User-technology-task	Cognitive absorption, work usage, recreational usage	Adult users	[64]
Sense of presence and perceived autonomy in VWs	Expectation-confirmation theory	Telepresence, social presence, perceived autonomy	Adult users	[50]
The effect of habit on continuous VW use	Theory of habit	Habit, perceived usefulness, enjoyment	Adult users	[9]

Due to the novelty and scarcity of empirical research on the subject [61], no established corpus of literature exists on the continued use of VWs [69]. Indeed, the review demonstrates that only a few

studies have been conducted thus far to investigate post-adoption behavior in VWs, and that a systematic integrative approach toward investigating the role of attitudinal beliefs, social influences, and system controllability has been lacking. Although the available studies include diverging theoretical orientations, the DTPB has not yet been subjected to an empirical scrutiny in this context. We hold that the nomological structure of the DTPB is well suited to accommodating and expanding upon the constructs that emerged from the review as it offers applicable constructs to address users' motives and goals related to use [9,60,64], social aspects during the use [50,69], and system characteristics [39,69]—all of which are assumed to be important determinants of VW post-adoption behavior.

2.1 Using the DTPB to explain the continued use of VWs

The decomposed theory of planned behavior (DTPB), as introduced by Taylor and Todd [76,77], was put forward to provide a more complete understanding of IT adoption and usage over other rather parsimonious models, such as the technology acceptance model (TAM), by proposing a set of additional behavioral determinants of use. Drawing upon the original theory of planned behavior (TPB), the DTPB asserts that attitude, subjective norms, and perceived behavioral control influence individuals' behavioral intention, which in turn determines actual behavior [3].

The attitude is viewed as a function of cognitive beliefs and refers to an “individual's positive or negative feeling (evaluative affect) about performing the target behavior” [33]. It can be considered an important antecedent of behavioral intentions in virtual worlds, as their use is basically voluntary leisure time activity. Subjective norm in turn represents the social influences on behavior and refers to the perception about whether others important to an individual believe that he or she should perform a particular behavior [33]. It can be expected to be an important factor in the VW use as well, because the use of VWs is highly social by nature. Finally, perceived behavioral control captures the constraints on behavior and refers to the “perceived ease or difficulty of performing a behavior and it is assumed to reflect past experience as well as anticipated impediments and obstacles” [3]. As the use of VWs requires specific capabilities from the users, perceived control might be rewarding, and, on the contrary, perceived lack of control might obstruct the intention to use. To be precise, as the use of

VWs typically requires control over an avatar in its dynamic environment, it supposedly places specific demands on the controllability of the system.

The DTPB extends models such as TPB, theory of reasoned action (TRA), and TAM by proposing a decomposition of attitude, subjective norm, and perceived behavioral control into attitudinal, normative, and control beliefs. Attitudinal beliefs concern the salient information or knowledge that an individual has about performing a particular behavior. Normative beliefs refer to referents' beliefs about whether the individual should or should not perform the behavior in question. Control beliefs refer to the beliefs about the presence of constructs that might facilitate or impede the behavior in question [32]. The decomposition into these three types of beliefs serves to plumb the complexity of the context-specific constructs underlying IT usage and thus is intended to provide a more thorough understanding of the usage of a particular IT artifact [76,77]. Indeed, IS scholars have successfully adopted the DTPB to explain IT usage in other fields than the VW use by making use of more context-specific belief structures [44,45].

Most studies deploying the DTPB have focused on the early stages of a system adoption process, while only a few have employed the DTPB to explain continued IT use [46]. This makes the application of the theory to predict the continued use of VWs of particular interest. The theoretical premise of the DTPB holds that "new information may lead to the formation of new beliefs or alter previously formed beliefs" [29], possibly influencing future decision-making. Acknowledging that beliefs and their relative importance might change over time, the DTPB covers a key aspect of IS continuance [11]. Moreover, while we admit that habit may contribute to the continued VW use [9], we hold that from the VW operators' decision-making vantage point, it is important to focus on the cognitive determinants of use intentions to understand the areas of motivational behavior that influence the continued VW use.

Finally, both intrinsic and extrinsic motivation may shape the attitude of the users of multi-purpose information systems (MPISS), of which VWs are an example [81]. That is, user behavior is likely to be influenced by the user's motivation as well as by other users acting in the same social setting. These characteristics of VWs are reflected in connection with the key constructs of the DTPB,

attitudinal beliefs, subjective norm, and behavioral control, which together form the backbone of its nomological structure, thereby making the employment of the DTPB interesting from both theoretical and contextual perspectives.

2.2 Underpinnings of users' motivational behavior in VWs

Although the DTPB provides a useful guiding framework regarding technology adoption, it remains quiet about which attitudinal beliefs, social influences and system controllability factors should be associated with VW use. Therefore, we draw from a wealth of appropriate theories to adapt the three sets of constructs of the DTPB into VW-related beliefs [79]. In doing so, we follow the steps taken by Taylor and Todd [76,77] and employ three associated theories: self-determination theory (SDT) [26], innovation diffusion theory (IDT) [67], and social cognitive theory (SCT) [7]. The use of SDT is justified by the fact that it details the different forms of motivations relevant to VW use. IDT in turn grasps the social influences deemed essential in the VW-adoption stages, and SCT examines the elements that affect the personal sense of system controllability.

Following SDT, users' behavioral attitudes are categorized into extrinsic and intrinsic motivation; the former involves perceived external rewards (e.g., salary, guilt, pressure) that induce individuals to engage in uninteresting behaviors whereas the latter is related to self-determined behaviors performed spontaneously for their own sake [26]. Although the dichotomy of extrinsic and intrinsic motivation has received widespread attention and empirical support in the literature on IT use [23], very few empirical studies [66,72] have sought to build explicitly on the SDT. Given that VWs are aimed at addressing both extrinsic and intrinsic motivation [51], we selected perceived usefulness and perceived enjoyment as proxies for both types of motivation.

Perceived usefulness is defined here as the degree to which a medium is perceived to provide certain benefits when performing certain tasks [24,43]. In a VW context, these benefits reflect the instrumental value noted by users as they complete tasks such as attending courses, trading digital property, and obtaining useful information from other users [51]. Such activities are rather characteristic for VWs, which makes an examination of perceived usefulness of particular interest.

In contrast, perceived enjoyment equals the extent to which using a system is “perceived to be enjoyable in its own right, apart from any performance consequences that may be anticipated.” [23]. The enjoyment that accompanies the use of a VW includes activities such as exploring and manipulating the appealing environmental attributes of VWs (e.g., virtual decoration and fashion shows) and playing various multi-user/stand-alone games (e.g., role playing and arcade games). These enjoyable activities are typical to VWs, which makes the inclusion of perceived enjoyment worthwhile.

The IDT explains the course of a diffusion process in which an individual typically gathers information about the advantages and disadvantages of an innovation by using communication channels within a social system that consists of individuals, informal groups, organizations, and other social subsystems [67]. Depending on whether such interaction is considered relevant in shaping an individual’s behavioral intentions vis-à-vis the attributes of an innovation, it might or might not influence behavior. To that end, the communication sources and routes that originate and carry such messages are categorized into interpersonal and mass media channels according to the distinctive effect exerted by social influence. An interpersonal channel refers to exchanges between two or more individuals that are effective in persuading individuals to change their behavior. Alternatively, mass media channels that involve media such as radio, television, or newspapers are important in disseminating awareness of a given innovation [67]. In line with this distinction in channels, scholars have categorized social influences accordingly into interpersonal influence and external influence [12,19]; we adopt this categorization here as well. As VWs are typically social in nature, and based on previous evidence that interpersonal influence most likely plays a role in shaping behavior in online social networks [14], we propose interpersonal influence as a component of subjective norm. Furthermore, as VWs do represent a rather innovative emerging class of IS, which has received relatively considerable attention in the media [31] and has promoted itself via online marketing [75], we adopt external influence as the second component of subjective norm.

Moreover, we use SCT to decompose perceived behavioral control. SCT posits a triadic reciprocal relationship among behavior, personal factors, and the environment. In other words, an individual’s behavior both influences and is influenced by personal factors and the environment [7]. Such a

presumption of an individual having the ability to influence his/her behavior, while simultaneously recognizing that his/her behavior is influenced by personal factors and the environment, is consistent with that of perceived behavioral control, which concerns personal perceptions of an individual's ability to perform a given behavior [2]. From this perspective, and drawing upon previous empirical evidence [44], we decompose perceived behavioral control into perceived ease of use, self-efficacy and social presence.

Perceived ease of use is defined here as the degree to which a person believes that using a particular system is free of effort [24]. We position the concept as a control belief as it mirrors an individual's capability to handle the complexity of the control of a medium. Given that VW usage requires users to learn to make use of an avatar to interact with and navigate through the system, a study into the role of ease-of-use is of particular interest [80].

Self-efficacy refers to the degree of self-confidence an individual has about his/her capability to execute a behavior [8]. Although the construct of self-efficacy may also be seen from a rather general trait-oriented perspective, in the VW context its medium-specific aspect is even more interesting [1,47]. The concept calls for renewed attention as the use of avatars to navigate within a system and interact with other users is a relatively new way of using information systems. The fact that users of VWs are constantly observed by and confronted with others when performing a target behavior puts the concept of self-efficacy in a new perspective. Not only might the confrontation with other users' observations exert social pressure on their self-confidence to perform the behavior in question, but the users might also feel that their ability can be both hampered by the actions of other users (e.g., losing a game because of other users' actions, being unable to purchase digital furniture as others already have them), and support from others (e.g., others can help solve problems related to special actions like trading virtual products).

Social presence is defined as the degree of human warmth and psychological presence associated with a VW [13,71]. Within the VW domain in general, social presence is pursued through the embodiment of avatars that provide users with a sense of being a part of the virtual environment. In this vein, users may experience close and immediate contact with other people inside the system. Given that social

presence has been shown to add richness to electronic communication [37] and that VW users look for social interaction [51], it represents a key affordance of VWs and thus is an important driver of usage intentions.

Although some VW studies have conceptualized social presence as an attitudinal construct [69], it can also be associated with environmental characteristics. Conceptually, our approach complies with media richness theory [22] where a media that is able to transmit social cues (e.g., immediacy) supports effective communication in equivocal situations. The social setting in VWs can often be equivocal [18] given that some of the users are constantly entering and leaving the platform, resulting in new groups being formed and activities being introduced. To this end, a VW’s ability for irradiating human contact and warmth make the use experience more comfortable in terms of system controllability. For these reasons, social presence can be positioned as a behavioral control belief.

Table 2. Key constructs of the study and their theoretical underpinnings

DTPB construct	Type of decomposed beliefs	Proposed decomposed beliefs	Theoretical underpinnings	Key references
Attitude	Attitudinal beliefs	Perceived enjoyment Perceived usefulness	Self-determination Theory	[26,76,77]
Subjective Norms	Normative beliefs	Interpersonal influence External influence	Innovation Diffusion Theory	[3,12,67]
Perceived Behavioral Control	Control beliefs	Perceived ease of use Self-efficacy Social presence	Social Cognitive Theory	[7,21,71,76,77]

Table 2 summarizes the DTPB constructs and the decomposed beliefs as investigated in this study. To further substantiate the selection of the proposed set of beliefs and frame our model within the existing body of literature, the next section proposes a research model that integrates the underpinning constructs into a research model on post-adoption behavior in VWs.

3 Research model and hypotheses

In line with the nomological structure of the DTPB [76,77], we propose a research model to explain VW users’ behavioral intentions to continue using a VW. The backbone of the model consists of the three established TPB constructs: users’ attitudes toward the behavior, subjective norms, and perceived behavioral control [32]. These three constructs are decomposed in beliefs that are assumed to be of particular interest in VW settings. The general logic behind the decomposition draws upon the

specific multipurpose character of VWs [81]. Especially in settings where multiple purposes (e.g., hedonic, utilitarian and social) motivate continued usage, it appears that there is “value in sacrificing parsimony to include a richer set of antecedents to predict adoption” [20]. By placing richness before simplicity, a deeper reconstruction of the constructs considered to be influential to users’ behavioral intentions is achieved [62]. In doing so, we are able to meet important model-building criteria, such as accuracy, depth, predictive power, and originality [15], thereby contributing to the theoretical and managerial value of our findings. The research model is presented in Figure 1. The remainder of this section justifies the individual relationships in the model predicated upon the IS literature and the literature on VWs in particular.

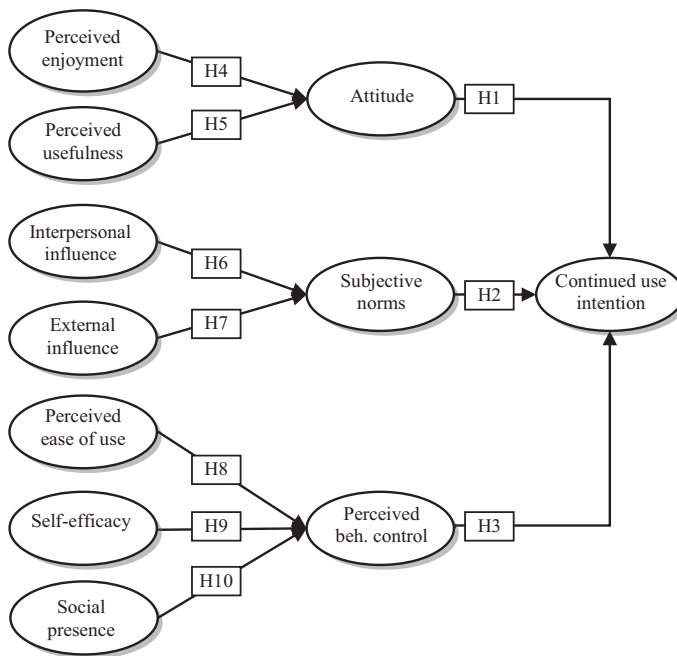

Figure 1. The research model and hypotheses

3.1 Determinants of continued use intention

Drawing on the core assumptions of the DTPB, we suggest that behavioral intention to use VWs is driven by three constructs: attitude toward a behavior, subjective norms, and perceived behavioral control. Previous research on VWs has provided accumulative support for this nomological structure.

For example, Shin [70] and Schwarz et al. [69] demonstrated the positive relationship between attitude and behavioral intention within a VW. Regarding the influence of subjective norms [3] in the VW context, Wu et al. [83] found that normative pressure favoring the use of a VW should influence users' use intention. Finally, perceived behavioral control, as defined in the TPB [3], reflects the perceptions of internal and external constraints on behavior. In the context of VWs, it can be understood as having the resources available from the environment to successfully use the system [69] and the degree to which an individual perceives his or her actions as a result of his or her own free will [50]. Altogether, perceived behavioral control is likely to reduce the cognitive effort associated with the usage decisions and thus contributes to making the use habitual or automatic behavior [28].

In sum, the discussion thus far leads us to posit the following hypotheses:

H1: *Attitude toward using a VW has a positive effect on a user's continued-use intention.*

H2: *Favorable subjective norms toward using a VW have a positive effect on a user's continued-use intention.*

H3: *Perceived behavioral control of using a VW has a positive effect on a user's continued-use intention.*

3.2 The influence of perceived usefulness and perceived enjoyment on attitude

VWs provide users both extrinsic and intrinsic value. This value includes how various technical features of the platforms enable users to fulfill certain tasks, such as voice chat, avatar interaction, and virtual meetings with people, thereby helping users to expand social relations in a manner that is better or more convenient than other types of IS [30,69]. As recently discussed by Schwarz et al. [69] VWs can provide users with a sense of enjoyment, pleasure and playfulness, as they can be fun and entertaining to use [81]. Nah et al. [63] highlighted the positive link between the enjoyment of use and behavioral intention in VWs. Bearing this in mind, we follow motivation theory [23,25,70] to assume that both types of value—namely, perceived usefulness and perceived enjoyment—as likely to influence attitude toward the use of a VW.

Taking perceived usefulness and perceived enjoyment as proxies for extrinsic and intrinsic value, it seems plausible to assume direct and positive influences of the two constructs on attitude toward using a VW. Barnes [9] found a positive link between the perceived enjoyment of using a VW and continuance intention in its use, whereas Verhagen et al. [80] showed a positive influence of both entertainment value and perceived usefulness on a user's attitude toward the use. Thus, it seems conceivable to assume that:

H4: *Perceived enjoyment of a VW has a positive effect on attitude toward using a VW.*

H5: *Perceived usefulness of a VW has a positive effect on attitude toward using a VW.*

3.3 The influence of interpersonal and external influences on subjective norms

One key characteristic in the use of a VW is that one's actions are to a large extent visible, as interaction with the system occurs via an avatar [69]. Given that peers familiar to the user may be active within the VW as well, and thus observe the actions performed by others, interpersonal influences are likely to affect the behavior to be performed [39]. In addition, VWs have put considerable efforts into creating awareness of their existence via online advertising (e.g. placement of banners) and social media (e.g. Twitter, Facebook). VWs have also been covered extensively by media in its broadest sense as the rise of innovative three-dimensional environments are considered as news items [69], suggesting that users of VW are confronted with both interpersonal influences and external influences when considering system usage.

Indeed, according to Bhattacharjee [12], information system users are confronted with social influences that can roughly be distinguished into interpersonal and external influences. Research on computer-mediated behaviors confirms that these two types of social influence play a role in shaping user behavior [84]. Rogers [67] suggests that interaction involving the use of IT is likely to occur with key interpersonal relationships [84]. Given the social nature of VWs, it seems plausible to assume that this assumption holds as interpersonal influences, as the opinions of friends, family, relatives and peers are likely to shape one's opinions of whether or not to use a VW [44].

Additionally, external influences conveyed by mass media reports, commercials, and well-known experts [12] can be assumed to exert a significant impact on one's social considerations to adopt a system. As the effects of external influence involve large audiences, it might even impart a persuasive effect, to which an individual might comply or accept as having authority over his or her personal views [16]. In sum, the above leads us to postulate the following hypotheses:

H6: Interpersonal influence has a positive effect on subjective norms for using a VW.

H7: External influence has a positive effect on subjective norms for using a VW.

3.4 The influence of self-efficacy, perceived ease of use and social presence on perceived behavioral control

In the VW context, perceived behavioral control is affected not only by the people with whom the user is interacting with in real time (i.e., the social environment), but also by the physical environmental element—namely, the system interface and the fact that navigation is executed through an avatar [81]. This notion conforms to the assumptions inherent in SCT, in which the environment is divided into social (i.e., people) and physical (i.e., information system) entities. Hence, by drawing on the assumptions supported by the SCT, and following findings from previous IS research in technology adoption [44], it is conceivable that self-efficacy, perceived ease of use, and social presence might have a positive relationship with perceived behavioral control.

Indeed, Compeau et al. [21] argued that perceived behavioral control is driven by perceptions of one's ability to manage (i.e., control) the technology that facilitates the actions being pursued. Lee and Kozar [56] confirmed this view by empirically validating that self-efficacy precedes perceived behavioral control. Comparably, it has been suggested that the complexity of using a system, which is the conceptual opposite of ease-of-use [78] negatively influences perceived behavioral control [76]. The rationale for this connection is that complexity of use affects personal perceptions about control by individuals who use the technology [44]. Bearing this in mind, it seems plausible to assume that the opposite is valid for ease of use. Therefore, we can expect that perceived ease of use has a positive influence on perceived behavioral control. Human warmth and sociability captured by social presence are likely to decrease barriers to asking for advice or assistance from other users and would promote

system usage. In addition, through facilitated social responses, social presence may reduce undesirable conduct such as cyber-bullying or virtual fraud [18] which would impede usage. Thus, we hypothesize:

H8: Self-efficacy has a positive effect on a user's perceived behavioral control in using a VW.

H9: Perceived ease of use has a positive effect on a user's perceived behavioral control in using a VW.

H10: Social presence of a VW has a positive effect on a user's perceived behavioral control in using a VW.

4 Empirical research

4.1 Data collection

For this study, data were collected via an online survey that targeted Finnish users of Habbo Hotel. With 273 million registered users, Habbo Hotel is regarded as one of the most popular and widely acknowledged teen-oriented VWs. Offering access through more than 30 local portals, Habbo Hotel has succeeded in rapidly increasing its customer base. Currently, Habbo Hotel customers between 13 and 18 years old account for 90% of the overall base, with the gender distribution being nearly equal [74]. Although the three-dimensional user interface has borrowed its retrospective design from older computer and console games, Habbo Hotel diverges from true gaming VWs (e.g., World of Warcraft) in that the designer-produced, progressively-advancing storyline is replaced by user-determined objectives. With countless virtual cafés, parks, and user-generated private rooms, Habbo Hotel provides an extensive environment within which users can interact with one another and play various non-violent games. For our study, we focused on the Finnish portal of Habbo Hotel, which implies that the experience of the users was tied to the Finnish-specific content of the portal once they logged in.

To collect the data, an invitation to participate voluntarily in the study was posted on the front page of the Finnish Habbo portal. Before logging in, users were confronted with this invitation. The invitation

led to a web-based questionnaire that included the research constructs of our model and some socio-demographics. The respondents were not offered incentives of any kind.

4.2 Measures and empirical inquiry

The constructs were measured using multi-item scales with a 7-point Likert scale. To ensure validity and reliability of the measurement, the scales were derived from established IS literature. Given that all constructs were psychological in nature, a reflective approach was used. To match the items to the context of our research setting, the wording of the original items was slightly modified. For example, for some items we changed the wording “the system” to the “VW’s name.” The measurement items with attendant literature references appear in Appendix A.

The original questionnaire was constructed in English, according to the wording guidelines presented in the literature on questionnaire design [35]. Given that most of the respondents were teens, and following good research ethics, it was decided to not ask for identifiable personal information (e.g., user names), which obviated the need for parental approval, and we only asked for gender and age as socio-demographic background information. After constructing the questionnaire, pilot testing was conducted among a population of more than 2,000 Canadian Habbo Hotel users who were asked to evaluate the linguistic intelligibility of the survey and propose improvements. Some refinements were made. The questionnaire was then translated into Finnish by two IS researchers who were both native Finnish speakers. Finally, the questionnaire was double-checked by a qualified translator and employees of the VW being investigated to ensure that the questions were interpretable for the target audience.

4.3 Sample

A total of 8,918 Habbo Hotel users clicked on the invitation to participate in the research. Of them, 3,265 completed the online questionnaire, which implies an approximate completion rate of 37%. To ensure the best possible quality of the responses, only the respondents who provided answers to all questions were included in the analysis. As 90% of Habbo Hotel users are between 13 and 18 years old, only respondents within this age range were analyzed. After applying these basic selection rules,

the final sample used for the analyses consisted of 921 respondents. Potential non-response bias was examined by comparing the demographic properties between early and late respondents. Here, we noted no significant difference in our *t*-test comparison between the first and the last 10% of the submissions. Table 3 presents a profile of the final sample in terms of gender, age, and experience with Habbo Hotel.

Table 3. Distribution of respondents in the sample (n = 921)

Category		Frequency	Percent
Gender	Female	554	60.7
	Male	367	39.3
Age	13	337	36.6
	14	261	28.3
	15	154	16.7
	16	91	9.9
	17	45	4.9
	18	33	3.6
	Experience	Less than 1 month	18
	1 - 6 months	55	6.0
	6 - 12 months	52	5.6
	1 - 2 years	141	15.3
	2 - 3 years	152	16.5
	3 - 4 years	187	20.3
	4 - 5 years	162	17.6
	More than 5 years	154	16.7

4.4 Data analysis

The data were analyzed using structural equation modeling (SEM) with Amos 8.0. A covariance-based approach was selected over a component-based approach as we wanted to test the research model in terms of both its predictive power and fit with the empirical data. A maximum likelihood estimation was conducted as it has been proven capable of providing reliable results with large samples and being robust to violations of multivariate normality. To assess model fit and construct validity, the data analysis began with a confirmatory factor analysis (CFA) of the measurement model. The CFA measurement model's goodness-of-fit was investigated. All fit indices indicated a good model fit (GFI = 0.907; TLI = 0.959; CFI = 0.965; SRMR = 0.046; RMSEA = 0.047). As such, evidence for the convergent validity, discriminant validity, and the uni-dimensionality of the measures was provided.

We further investigated convergent validity by computing and examining the indicator factor loadings, composite reliabilities, and average variance extracted (AVE). Convergent validity was re-confirmed as all indicator factor loadings exceeded the value of 0.70, the composite reliabilities exceeded the value of 0.80, and the AVEs were above the value of 0.50 [34]. Thus, all measures performed well and met the criteria for convergent validity. Appendix B summarizes the tests for convergent validity.

To conclude the tests for discriminant validity, we investigated whether the AVE for each construct was higher than the squared correlation between it and all other constructs (see Appendix C) [34]. Although the test for discriminant validity of the measurement model was met, we noticed a rather high correlation of the two decomposed beliefs within the perceived behavioral control block. In retrospect, based on the empirical evidence from previous IS adoption studies employing DTPB [44], as well as TPB-based studies in general [5], this higher inter-construct correlation was anticipated. However, as we only used measures previously tested in the established literature, and given that the AVEs strictly exceeded the squared correlations between the constructs, the overall fit indices of the measurement model also suggested discriminant validity. Hence, a lack of discriminant validity was unlikely to be an issue in the present study. Still, to examine the issue further, we investigated item cross-loadings. Each item loaded higher on its intended construct than any other constructs, thereby providing additional support for discriminant validity [34]. Furthermore, as the construct reliabilities were high (> 0.80) and the sample size was large, these characteristics supported the notion that a sufficient level of discriminant validity was achieved [40].

We used Baron and Kenny's [10] analysis to test for mediation among our latent constructs. Due to that our research model includes seven separate paths to test for mediation, we summarize the findings here. First, we estimated the effect of all our antecedents to the continued use intention. Assuming that all relationships were significant, we then estimated the effects of our independent variables on the continued use intention. Mediation is supported if the effects on continued use intention drop significantly. In sum, the mediation argument holds as the test supports mediation in all paths except the one from perceived enjoyment to the continued use intention. The result is consistent with prior knowledge on the influence of behavioral beliefs on behavioral intention reported widely in studies using the TPB [77].

Finally, we used a marker variable technique to examine to what extent the correlations might have been inflated by common method bias (CMB) [59]. The equations from Malhotra et al. [59] were used to calculate the CMB-adjusted correlations. The adjusted correlation matrix was then used as an input to test the structural model. The CMB-adjusted results were consistent with the original data; the results for hypothesized relationships remained, and the R-squared dropped only marginally. In sum, the tests indicated that CMB is not likely to distort the results.

4.5 Results

The results of the analysis are presented in Figure 2.

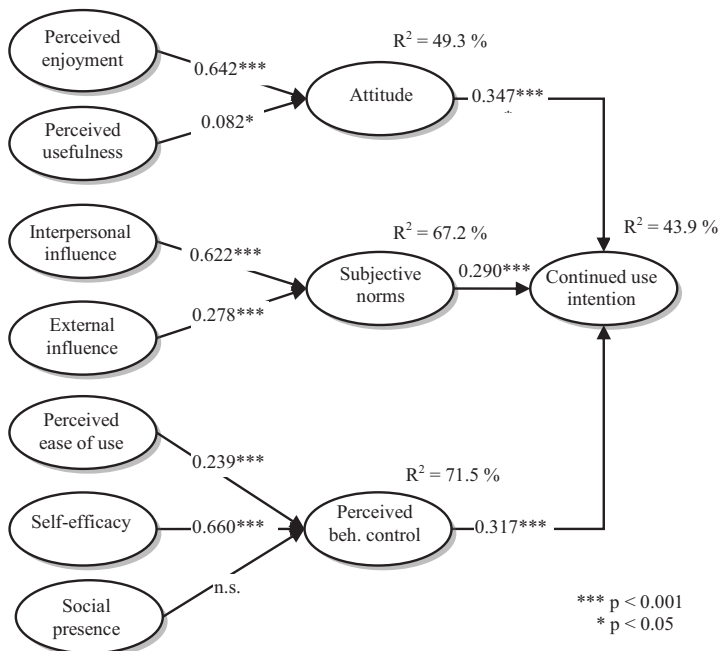

Figure 2. Structural model of the study and results of the analysis

The fit of the structural model to the data was found to be satisfactory (GFI = 0.884; TLI = 0.950; CFI = 0.955; SRMR = 0.062; RMSEA = 0.053). Overall, the findings provide support for all hypotheses, except H10 which proposed that social presence was a determinant of perceived behavioral control. Moreover, due to the weak standardized path coefficient seen in H5, which pertains to the effect of perceived usefulness of the VW on users' attitudes toward the use of VW, it was only marginally supported. Although this result may seem intelligible in the context of the investigated VW, the use of

which is not limited to utilitarian purposes, this finding warrants some caution. Table 4 summarizes the implications of the results for our hypothesis testing

Table 4. Summary of the hypotheses testing

Hypothesis	Result
H1: Attitude → Continued use intention (+)	Supported
H2: Perceived behavioral control → Continued use intention (+)	Supported
H3: Subjective norms → Continued use intention (+)	Supported
H4: Perceived enjoyment → Attitude toward using a VW (+)	Supported
H5: Perceived usefulness → Attitude toward using a VW (+)	Supported (weak effect)
H6: Interpersonal influence → Subjective norms (+)	Supported
H7: External influence → Subjective norms (+)	Supported
H8: Perceived ease of use → Perceived behavioral control (+)	Supported
H9: Self-Efficacy → Perceived behavioral control (+)	Supported
H10: Social presence → Perceived behavioral control (+)	Not supported

The predictive value of the structural model was rather strong. The amount of variance explained by the model in the continued use intention (43.9%) supports the use and further investigation of the three basic DTPB constructs in a VW context. Attitude was the strongest predictor of continued use intention, followed by perceived behavioral control and subjective norms. The selected beliefs explained 49.3% of the variance of the attitude, 71.5% of the variance of perceived behavioral control, and 67.2% of the variance of subjective norms. As such, these findings confirm the predictive value of the proposed decomposed beliefs in VW settings.

After analyzing the data using the structural model, we performed a set of post-hoc tests to identify any potential moderating effects of gender, age, and length of experience with the VW in the hypothesized relationships as well as to assess the predictive validity of the identified decomposed structure and the influence of the three DTPB constructs on the continued use intention. The motive for the subsample tests was that a successful replication of the model (significant beta values, high amounts of variance explained) across the gender and experience groups would underscore the validity of our findings.

To finalize the analysis, we applied the procedures advanced by Jöreskog and Sörbom [49] by splitting the sample into two subgroups and using a chi-square difference test to examine if inter-group differences existed. For experience and age, the mean values were used to split the data into two subgroups. The results reconfirmed the significant effects and rather high variances explained across

the different groups, thereby providing support for the general validity of our main model structure. With regard to the moderating effects, the analysis indicated that the formation of the subjective norm was influenced by experience so that interpersonal influence clearly outweighed external influence among the more experienced respondents. However, among less experienced respondents interpersonal and external influence exerted equal influence on the subjective norm. The results from testing the model with different subgroups, and the identified moderating effects are presented in Appendix 4.

5 Discussion and conclusions

Our objective was to investigate how and to what extent attitudinal beliefs, social influence, and system controllability predict users' intentions to remain engaged in VWs. To achieve this goal, we developed an integrative research model grounded on the DTPB and conducted an analysis on large-scale empirical data concerning VW users' perceptions and continued-use intentions. Hence, this study contributes to the research on other VWs by providing empirical support for the use of DTPB in the endeavors to explain user behavior.

First, the results demonstrated that the core components of planned behavior, attitude, subjective norms, and perceived behavioral control exert direct and significant influence on the continued use of VWs. In particular, the results corroborate the importance of the attitude and perceived behavioral control as strong determinants of VW continuance intentions.

Second, all decomposed beliefs add to their endogenous constructs (i.e., attitude, subjective norm, and perceived behavioral control). This finding suggests that decomposing belief structures indeed adds to our understanding of the continued use of VWs compared to more monolithic approaches and that they correspond with the findings noted in previous research [77].

Third, intrinsic motivation, referents, and self-efficacy exert particularly strong effects on their corresponding endogenous constructs and can thus be labeled as strong indirect determinants of continuance intentions. When a VW is enjoyable and comfortable to use, and the perspective is

supported by the positive opinions of friends and other referents, it does indeed seem to disclose the principal underlying constructs that stimulate the key beliefs supporting continued VW usage.

5.1 Theoretical implications

From a theoretical standpoint, this study adds to the existing knowledge about the post adoption of VVs in several ways. First, it demonstrates that incorporating the basic beliefs associated with IS usage and additional constructs that might lead to usage could indeed facilitate a more complete understanding of the continued use of a VW [77]. As VVs can be regarded as multipurpose systems characterized by avatar-based navigation and multiple users, the employment of such a comprehensive approach is preferable to adopting more parsimonious approaches, as it will contribute to our understanding by addressing beliefs at different levels of abstraction [76].

Second, the study sheds light on the predictive value of the principles of self-determination, innovation diffusion, and social cognition as underlying theoretical paradigms. The study not only confirms the predictive value of each of these perspectives (thereby supporting DTPB), but the empirical outcomes also indicate that the part of the nomological structure associated with self-determination and social cognition seems more important than the portions associated with innovation diffusion. This finding is likely to guide future theory-building attempts as it emphasizes the value of beliefs typically associated with self-determination and social cognition.

Third, the study provides insights into the role played by decomposed beliefs as proposed by the three underlying theories. The self-determination perspective was used to decompose the concept of individual attitude. The results strongly favor intrinsic motivation over extrinsic motivation as the determinant of attitude. Results from previous literature regarding the importance of intrinsic and extrinsic motives in VW use have been somewhat mixed [48,70,60]. In this context, the diminishing role of perceived usefulness might also be due to the recognition that VVs have become remarkably pervasive—particularly among teens—and that their usefulness today remains undisputed. This phenomenon has also been recognized in previous research on the use of multipurpose systems [43].

Using the IDT, our decomposition of the concept of subjective norm provided us with constructs indicating that interpersonal channels are much stronger determinants of action in the investigated context than mass media. This finding implies that word-of-mouth advertising outperforms the more supplier-based forms of communication in reaching online audiences, as suggested by Brown et al. [14], and helps determine users' continuance behavior, which is in line with the findings of Gruen et al. [41]. The results demonstrate that the respondents did not perceive a particularly strong social pressure to be involved in Habbo Hotel. One reason for this could be that revealing one's real-life identity is prohibited inside Habbo Hotel in order to protect the users. Such a protection might make the users feel more comfortable in making their decisions autonomously.

Finally, social cognitive theory was used to decompose the concept of perceived behavioral control. The results show that self-efficacy is a stronger perceived behavioral control determinant than perceived ease of use or social presence. VW operators have paid substantial attention to developing user-friendly navigational mechanisms and user interfaces to sustain user attraction [39]. In such situations, perceived ease of use is less likely to be a dominant determinant of behavioral constructs [82]. The fact that self-efficacy did have a strong effect on perceived behavioral control could be attributed to a large extent to the social nature of VWs. It is likely that the confrontation with other users' observations makes users less comfortable in using the VW, while some unpredictable dynamic beyond social presence also exists as other users might unexpectedly hamper or support the behavior to be performed. Future research should explore the aspect of social dynamics of VWs in more detail.

5.2 Practical implications

This study also offered some valuable practical implications, as VW operators are increasingly focusing on the drivers that lead to sustained participation in their user environments. The need to sustain the relationship between VWs and their users has become increasingly important for VW operators, as the supply side of the market is expected to grow from 150 to almost 900 VWs between 2009 and 2012 [55]. Thus, VW operators face unique challenges as they seek to expand their market share while maintaining their existing clientele.

To guide operators in these challenges, our findings translate into three practical recommendations. First, when considering decisions about achieving and maintaining a balance between the features that appeal to users' intrinsic and extrinsic motives, our findings emphasize that a focus on those strategic design mechanisms that facilitate intrinsic motivation is generally of tremendous importance as such constructs have a reinforcing effect on user engagement. Thus, making the VW usage experience highly enjoyable is of key importance for operators striving to create lock-ins for their users. This is not to say that the facets of extrinsic motivation should be ignored completely. Some enjoyable activities in VWs are related to extrinsic goals. For example, Habbo Hotel currently rewards its users with a virtual currency for sustained participation and game play. In turn, the currency provides a means to purchase virtual items that add to a user's status, both within the Habbo Hotel environment and in real life. Thus, playing games in Habbo Hotel can be instrumental in fulfilling the extrinsic goal of increased social status. This example illustrates that combining extrinsic goals with intrinsic motives in system usage might be fruitful for stimulating continued use and suggests that in some situations extrinsic motives could still warrant further attention.

In addition, the results indicate that the social influence of important individuals is a viable determinant in the continued use of VWs. Especially in virtual environments that attract young users, peer pressure is recognized as an important factor that influences behavior [73]. To better facilitate this kind of social influence, VW operators should implement features that provide users with the means to gather information about the beliefs and values held by other users (e.g., board of likes and dislikes, design contests). Such features can support the development of interpersonal relationships among VW users. For example, in order to establish bonds among VW users, offering a feature that enables the browsing of other users' profiles can be very useful. Similarly, functions that automatically update user profiles based on usage behavior and preferences will increase the value of such a browsing mechanism.

The fact that mass media has exerted minimal impact in shaping social influence is an interesting finding from a managerial perspective and suggests that traditional mass media advertising is not necessarily the most efficient way to influence users—whether existing or sought after. As peers are likely to remain the primary source of social influence, mechanisms such as peer-to-peer

recommendation boards and viral marketing are likely to be more effective than magazine advertisements and radio commercials.

Finally, the perception of control seems an important determinant of continued VW use. Users are willing to spend time to gain control over such VWs, as long as doing so does not substantially disturb engagement in the activity itself. Thus, giving VW users the feeling of “being in control” must be held as an important design principle for VW operators. As a result, empowering users to effectively utilize the features of the VW is advisable. The results show that perceived ease of use is considered less influential than self-efficacy, which indicates that it is more important to focus on features that make VW users feel comfortable rather than those that make VW usage easier. In order to maintain users’ perceptions of self-efficacy, designers should refrain from making radical changes when implementing new features in VW environments that are already in use.

5.3 Limitations and avenues for further research

Our study has several limitations. First, the data collection was delimited to users of one VW in one country only and hence we did not compare the findings across cultural or geographical boundaries. More research is needed to investigate whether the results will remain valid for other VWs and in other cultural contexts. Second, as the respondents in our study were primarily teens, the findings noted herein must be interpreted with caution when considering other age categories. Additional research, including surveys of adult users, would certainly be appropriate. Third, as the present study captured a short-term snapshot of continued use intentions, longitudinal research efforts should be conducted to determine the validity of the proposed model and findings over time. Fourth, the decomposed beliefs in the model were selected because of their applicability to VW settings and the lack of attention in the current post-adoption literature; however, our set of factors was by no means complete. For example, continued IT usage is often influenced by habit [57,65]. While we focused on the role of motivation, social influence and behavioral control, future studies could incorporate habit in the DTPB framework.

Our study gives rise to several avenues for further research. First, our study focused primarily on one aspect of post-adoption behavior, which is user intention to continue VW use. However, other

important VW post-adoption behaviors such as word-of mouth and repurchase behavior could also be of high interest and there is a call for their future examination [4,52]. Second, unfolding the construct of referents would yield valuable information about the social influence of “virtual” compared to “real” friends in the general social IT system context. Third, regarding the role and nature of social influence, beyond normative pressure alone, a large number of users in general and those within one’s social circle are likely to make interaction and communication in the VW more active and interesting. Such an informational influence, defined by Deutsch and Gerard [27] as the “influence to accept information from another as evidence about reality” (p. 629), might therefore differ by the size of the VW. In sum, further research could empirically segregate the normative and informational influences and facilitate a deliberate examination of the extent to which the presence of other users, known and unknown, influence user decisions regarding continued VW use.

Given the conceptual breadth of social presence and its linkages to related constructs such as telepresence and co-presence [58], additional research extending the investigative locus of presence and examining the interplay among presence, motivation, social influence and system controllability would extend the understanding of social dynamics and user experience in VWs. Moreover, VWs employ different methods to collect revenue from users, such as access fees or subscriptions for premium accounts. It is likely that the cost of continued use is a salient construct determining the post-adoption of VWs. Hence, we encourage future researchers to investigate the role of fees and revenue models in continued use. Further research could also focus on exploring the interrelationships within the determinants of attitude, subjective norm, and perceived behavioral control. As previously investigated in the context of technology acceptance research, ease of use could have a direct impact on perceived usefulness [25]. As a result, it might be plausible to assume that additional relationships exist among the other determinants as well. For example, the existence of a relationship between ease of use and self-efficacy has already been advanced [76] in the IS research. Further investigation into the interrelationships among these constructs can therefore contribute to even more comprehensive understanding of teenage users’ behavior in VWs. Congruently, as the influence of behavioral beliefs on continued use intentions is not fully mediated by attitudes, further research focusing on the direct belief-intention relationships could substantiate our findings.

Appendix A Constructs and Items

Construct	Item	References
Attitude (ATT)		
	All things considered, using <VW name> is...	
ATT1	Extremely bad...good	[3]
ATT2	Extremely dissatisfying...satisfying	
ATT3	Extremely displeasing...pleasing	
ATT4	Extremely terrible...delightful	
Perceived usefulness (PU)		
	Using <VW name> ...	
PU1	Helps me to stay in close touch with my friends	[23]
PU2	Helps me to stay in close touch with people I know.	
PU3	Helps me to make new friends more efficiently.	
PU4	Comes in handy for my communication	
Perceived enjoyment (ENJ)		
ENJ1	It is enjoyable to use <VW name>.	[23,44]
ENJ2	It is fun to use <VW name>.	
ENJ3	It is entertaining to use <VW name>.	
Subjective norm (SN)		
SN1	People who influence me think I should use <VW name>.	[3]
SN2	Among my friends, using <VW name> is widely accepted.	
SN3	People who are important to me use <VW name>.	
Interpersonal influence (INT)		
INT1	My family thinks I should use <VW name>.	[3,12,44]
INT2	My friends think I should use <VW name>.	
INT3	My relatives think I should use <VW name>.	
External influence (EXT)		
EXT1	I feel pressure from media and commercials to use <VW name>.	[12]
EXT2	I feel encouraged by media and commercials to use <VW name>.	
EXT3	I feel persuaded by media and commercials to use <VW name>.	
Social Presence (SP)		
SP1	There is a sense of human contact in <VW name>.	[36]
SP2	There is a sense of sociability in <VW name>.	
SP3	There is a sense of human warmth in <VW name>.	
Perceived behavioral control (PBC)		
PBC1	I have the resources, knowledge, and ability to use <VW name>.	[3,76]
PBC2	I can use <VW name>.	
PBC3	I know how to use <VW name>.	
PBC4	Using <VW name> it entirely within my control.	
Self-efficacy (SE)		
SE1	I feel comfortable using <VW name> on my own.	[76]
SE2	I can easily operate in <VW name> on my own.	
SE3	I feel comfortable using <VW name> even if there is no one around me to tell how to use it.	
Perceived ease of use (PEOU)		
PEOU1	Using <VW name> to communicate with others is clear and understandable.	[24,25]
PEOU2	Navigation through the menus and toolbars in <VW name> is easy to do.	
PEOU3	It is easy to learn how to use all that is provided in <VW name>.	
Continued use intention (CUI)		
CUI1	I intend to continue using <VW name> during the next three months.	[3,76]
CUI2	I intend to continue using <VW name> frequently during the next three months.	
CUI3	I will keep on using <VW name> in the future.	

Appendix B Convergent validity

Item	Mean	Std.Dev.	Loading	Composite Reliability	Cronbach's Alpha	AVE
ATT1	5.022	1.658	0.861	0.935	0.901	0.758
ATT2	4.845	1.603	0.854			
ATT3	5.055	1.666	0.896			
ATT4	5.092	1.711	0.926			
PU1	4.685	2.142	0.881	0.931	0.931	0.756
PU2	4.837	2.052	0.866			
PU3	4.598	2.139	0.891			
PU4	4.939	2.031	0.878			
ENJ1	5.012	1.722	0.887	0.905	0.944	0.715
ENJ2	5.553	1.590	0.927			
ENJ3	5.401	1.607	0.93			
SN1	3.453	2.075	0.837	0.871	0.87	0.675
SN2	3.853	2.192	0.814			
SN3	3.481	2.059	0.845			
EXT1	2.896	2.105	0.865	0.886	0.882	0.684
EXT2	3.168	2.171	0.886			
EXT3	3.338	2.138	0.794			
INT1	3.061	1.854	0.934	0.950	0.906	0.721
INT2	2.957	1.855	0.78			
INT3	3.316	2.065	0.938			
SP1	5.152	1.870	0.746	0.880	0.876	0.681
SP2	4.986	1.842	0.898			
SP3	4.570	1.951	0.877			
PBC1	5.831	1.642	0.702	0.923	0.913	0.751
PBC2	6.375	1.304	0.969			
PBC3	6.400	1.287	0.973			
PBC4	6.121	1.455	0.798			
SE1	6.296	1.374	0.919	0.911	0.95	0.699
SE2	6.316	1.342	0.94			
SE3	6.278	1.401	0.928			
PEOU1	5.851	1.609	0.857	0.908	0.91	0.697
PEOU2	5.822	1.683	0.877			
PEOU3	5.949	1.590	0.902			
CUI1	4.873	2.115	0.898	0.917	0.906	0.702
CUI2	5.570	1.834	0.871			
CUI3	5.280	1.947	0.859			

Appendix C Squared correlations between the latent constructs (AVEs in the main diagonal)

ATT	0.758										
CUI	0.285	0.702									
ENJ	0.469	0.517	0.715								
EXT	0.102	0.062	0.097	0.684							
PBC	0.062	0.181	0.173	0.001	0.751						
PEOU	0.204	0.343	0.353	0.029	0.448	0.697					
INT	0.143	0.149	0.194	0.353	0.009	0.053	0.702				
SE	0.040	0.169	0.112	0.000	0.672	0.397	0.006	0.721			
SN	0.270	0.259	0.354	0.406	0.024	0.125	0.594	0.007	0.675		
PU	0.317	0.358	0.549	0.220	0.077	0.224	0.266	0.042	0.494	0.756	
SP	0.293	0.386	0.554	0.130	0.135	0.296	0.200	0.102	0.333	0.518	0.681

Appendix D Test of moderating effects: Gender, experience and age (significant differences in bold)

Subgroup	Gender		Experience		Age	
	Female (model R ² 41.9 %)	Male (model R ² 46.7 %)	1 month – 3 Years (model R ² 42.4 %)	More than 3 Years (model R ² 44.8 %)	13 & 14 years (model R ² 41.1 %)	15-18 years (model R ² 48.5 %)
ATT → CUI	0.356***	0.332***	0.277***	0.399***	0.374***	0.299***
SN → CUI	0.308***	0.259***	0.291***	0.254***	0.282***	0.289***
PBC → CUI	0.284***	0.361***	0.359***	0.296***	0.278***	0.386***
PU → ATT	n.s.	0.124*	n.s.	0.165***	0.113*	n.s.
ENJ → ATT	0.644***	0.638***	0.659***	0.625***	0.615***	0.710***
INT → SN	0.700***	0.503***	0.467***	0.733***	0.576***	0.743***
EXT → SN	0.176***	0.423***	0.467***	0.138**	0.306***	0.199***
PEOU → PBC	0.219***	0.239***	0.410***	0.165***	0.227***	0.250***
SE → PBC	0.724***	0.610***	0.440***	0.770***	0.630***	0.706***
SP → PBC	n.s.	n.s.	0.084*	n.s.	n.s.	n.s.

*** p < 0.001; * p < 0.05

References

- [1] R. Agarwal, V. Sambamurthy, M.S. Ralph, Research report: The evolving relationship between general and specific computer self-efficacy - An empirical assessment, *Information Systems Research* 11 (4) (2000) 418-430.
- [2] I. Ajzen, Perceived Behavioral Control, Self-Efficacy, Locus of Control, and the Theory of Planned Behavior, *Journal of Applied Social Psychology* 32 (4) (2002) 665-683.
- [3] I. Ajzen, The Theory of Planned Behavior, *Organizational Behavior and Human Decision Processes* 50 (2) (1991) 179-211.
- [4] A. Animesh, A. Pinsonneault, Sung-Byung Yang, W. Oh, An Odyssey into Virtual Worlds: Exploring the Impacts of Technological and spatial Environments on Intention to Purchase Virtual Products, *MIS Quarterly* 35 (3) (2011) 789-810.
- [5] C.J. Armitage, M. Conner, Efficacy of the Theory of Planned Behaviour: A meta-analytic review, *British Journal of Social Psychology* 40 (4) (2001) 471-499.
- [6] W.S. Bainbridge, The Scientific Research Potential of Virtual Worlds, *Science* 317 (5837) (2007) 472-476.
- [7] A. Bandura, *Social Foundations of Thought and Action: A Social Cognitive Theory*, Prentice-Hall, Englewood Cliffs, NJ, 1986.
- [8] A. Bandura, Self-efficacy: Toward a unifying theory of behavioural change, *Psychological Review* 84 (2) (1977) 191-215.
- [9] S.J. Barnes, Understanding use continuance in virtual worlds: Empirical test of a research model, *Information & Management* 48 (8) (2011) 313-319.
- [10] R.M. Baron, D.A. Kenny, The Moderator-Mediator Variable Distinction in Social Psychological Research: Conceptual, Strategic, and Statistical Considerations, *Journal of personality and social psychology* 51 (6) (1986) 1173-1182.
- [11] A. Bhattacharjee, Understanding Information Systems Continuance: An Expectation-Confirmation Model, *MIS Quarterly* 25 (3) (2001) 351-370.
- [12] A. Bhattacharjee, Acceptance of E-Commerce Services: The Case of Electronic Brokerages, *IEEE Transactions on Systems, Man & Cybernetics - Part A: Systems and Humans* 30 (4) (2000) 411-420.

- [13] F. Biocca, C. Harms, J.K. Burgoon, Toward a More Robust Theory and Measure of Social Presence: Review and Suggested Criteria, *Presence: Teleoperators and Virtual Environments* 12 (5) (2003) 456-480.
- [14] J. Brown, A.J. Broderick, N. Lee, Word of mouth communication within online communities: Conceptualizing the online social network, *Journal of Interactive Marketing* 21 (3) (2007) 2-20.
- [15] M. Bunge, The weight of simplicity in the construction and assaying of scientific theories, *Philosophy of Science* 28 (2) (1961) 120-149.
- [16] R.E. Burnkrant, A. Cousineau, Informational and Normative Social Influence in Buyer Behavior, *Journal of Consumer Research* 2 (3) (1975) 206-215.
- [17] A.R. Chaturvedi, D.R. Dolk, P.L. Drnevich, Design Principles for Virtual Worlds, *MIS Quarterly* 35 (3) (2011) 673-684.
- [18] T. Chesney, I. Coyne, B. Logan, N. Madden, Griefing in virtual worlds, *Information Systems Journal* 19 (6) (2009) 525-548.
- [19] C. Chiu, M. Hsu, E.T.G. Wang, Understanding knowledge sharing in virtual communities: An integration of social capital and social cognitive theories, *Decision Support Systems* 42 (3) (2006) 1872-1888.
- [20] R.P. Christopher, S.H. John, M. Vandenbosch, Research report: Richness versus parsimony in modeling technology adoption decisions - Understanding merchant adoption of a smart card-based payment system, *Information Systems Research* 12 (2) (2001) 208-222.
- [21] D. Compeau, A.H. Christopher, S. Huff, Social cognitive theory and individual reactions to computing technology: A longitudinal study, *MIS Quarterly* 23 (2) (1999) 145-158.
- [22] R. Daft, R.H. Lengel, Information richness: A new approach to managerial behavior and organizational design, in: B.M. Staw and L.L. Cummings (Eds.), *Research in organizational behavior: an annual series of analytical essays and critical reviews*, JAI Press, Greenwich, CT, 1984, pp. 191-233.
- [23] F.D. Davis, R.P. Bagozzi, P.R. Warshaw, Extrinsic and Intrinsic Motivation to Use Computers in the Workplace, *Journal of Applied Social Psychology* 22 (14) (1992) 1111-1132.
- [24] F.D. Davis, Perceived Usefulness, Perceived Ease of Use, and User Acceptance of Information Technology, *MIS Quarterly* 13 (3) (1989) 319-340.
- [25] F.D. Davis, R.P. Bagozzi, P.R. Warshaw, User Acceptance of Computer Technology: A Comparison of Two Theoretical Models, *Management Science* 35 (8) (1989) 982-1003.
- [26] E. Deci, R.M. Ryan, The "What" and "Why" of Goal Pursuits: Human Needs and the Self-Determination of Behavior, *Psychological Inquiry* 11 (4) (2000) 227-268.
- [27] M. Deutsch, H.B. Gerard, A study of normative and informational social influences upon individual judgment, *Journal of Abnormal and Social Psychology* 51 (3) (1955) 629-636.
- [28] U.M. Dholakia, R.P. Bagozzi, L.K. Pearo, A social influence model of consumer participation in network- and small-group-based virtual communities, *International Journal of Research in Marketing* 21 (3) (2004) 241-263.
- [29] J. Doll, I. Ajzen, Accessibility and Stability of Predictors in the Theory of Planned Behavior, *Journal of Personality & Social Psychology* 63 (5) (1992) 754-765.
- [30] M. Fetscherin, C. Lattermann, User Acceptance of Virtual Worlds, *Journal of Electronic Commerce Research* 9 (3) (2008) 231-242.
- [31] H. Finn, *The Reality of the Virtual*, 2011, <http://online.wsj.com/article/SB10001424053111903285704576556932506260962.html>, retrieved: January 1, 2012.
- [32] M. Fishbein and I. Ajzen, *Predicting and changing behavior: the reasoned action approach*, Psychology Press, New York, NY, 2010.

- [33] M. Fishbein and I. Ajzen, *Belief, Attitude, Intention and Behavior: An Introduction to Theory and Research*, Addison-Wesley, Reading, MA, 1975.
- [34] C. Fornell, D.F. Larcker, Evaluating structural equation models with unobservable variables and measurement error, *Journal of Marketing Research* 18 (1) (1981) 39-50.
- [35] F.J. Fowler Jr, *Improving survey questions: Design and evaluation*, Sage Publications, Thousand Oaks, CA, 1995.
- [36] D. Gefen, D.W. Straub, Consumer trust in B2C e-Commerce and the importance of social presence: experiments in e-Products and e-Services, *Omega* 32 (6) (2004) 407.
- [37] D. Gefen, Gender Differences in the Perception and Use of E-Mail: An Extension to the Technology Acceptance Model, *MIS Quarterly* 21 (4) (1997) 389-400.
- [38] L. Goel, I. Junglas, B. Ives, N. Johnson, Decision-making in-socio and in-situ: Facilitation in virtual worlds, *Decision Support Systems* 52 (2) (2012) 342-352.
- [39] L. Goel, N.A. Johnson, I. Junglas, B. Ives, From Space to Place: Predicting Users' Intentions to Return to Virtual Worlds, *MIS Quarterly* 35 (3) (2011) 749-771.
- [40] R. Grewal, J.A. Cote, H. Baumgartner, Multicollinearity and Measurement Error in Structural Equation Models: Implications for Theory Testing, *Marketing Science* 23 (4) (2004) 519-529.
- [41] T.W. Gruen, T. Osmonbekov, A. Czaplewski J., eWOM: The impact of customer-to-customer online know-how exchange on customer value and loyalty, *Journal of Business Research* 59 (4) (2006) 449-456.
- [42] Y.S. Hau, Y. Kim, Why would online gamers share their innovation-conducive knowledge in the online game user community? Integrating individual motivations and social capital perspectives, *Computers in Human Behavior* 27 (2) (2011) 956-970.
- [43] S. Hong, J.Y.L. Thong, K.Y. Tam, Understanding continued information technology usage behavior: A comparison of three models in the context of mobile internet, *Decision Support Systems* 42 (3) (2006) 1819-1834.
- [44] J.J.P. Hsieh, A. Rai, M. Keil, Understanding Digital Inequality: Comparing Continued use Behavioral Models of the Socio-Economically Advantaged and Disadvantaged, *MIS Quarterly* 32 (1) (2008) 97-126.
- [45] M. Hsu, C. Yen, C. Chiu, C. Chang, A longitudinal investigation of continued online shopping behavior: An extension of the theory of planned behavior, *International Journal of Human-Computer Studies*, 64 (9) (2006) 889-904.
- [46] M. Hsu, C. Chiu, Predicting electronic service continuance with a decomposed theory of planned behaviour, *Behaviour & Information Technology*(5) (2004) 359-373.
- [47] M. Hsu, C. Chiu, Internet self-efficacy and electronic service acceptance, *Decision Support Systems* 38 (3) (2004) 369-381.
- [48] G. Hua, D. Haughton, Virtual worlds adoption: a research framework and empirical study, *Online Information Review* 33 (5) (2009) 889-900.
- [49] K.G. Jöreskog and D. Sörbom, *LISREL 8: Structural equation modeling with the SIMPLIS command language*, Scientific Software International, Chicago, IL., 1993.
- [50] Y. Jung, Understanding the Role of Sense of Presence and Perceived Autonomy in Users' Continued Use of Social Virtual Worlds, *Journal of Computer-Mediated Communication* 16 (4) (2011) 492-510.
- [51] Y. Jung, H. Kang, User goals in social virtual worlds: A means-end chain approach, *Computers in Human Behavior* 26 (2) (2010) 218-225.
- [52] S.S. Kim, J. Son, Out of Dedication or Constraint? A Dual Model of Post-Adoption Phenomena and Its Empirical Test in the Context of Online Service, *MIS Quarterly* 33 (1) (2009) 49-70.

- [53] S.S. Kim, N.K. Malhotra, A Longitudinal Model of Continued IS Use: An Integrative View of Four Mechanisms Underlying Post-adoption Phenomena, *Management Science* 51 (5) (2005) 741-755.
- [54] kZero, Virtual World registered accounts reaches 1.7 billion in Q4 2011, kZero, 2011, <http://www.kzero.co.uk/blog/virtual-world-registered-accounts-reach-1-7bn-q4-2011/>, Retrieved September 8, 2012
- [55] kZero, Virtual Worlds: 2011 and beyond. Key industry trends and market developments, 2010, A kZero Worldwide Report, pp. 1-27.
- [56] Y. Lee, K.A. Kozar, An empirical investigation of anti-spyware software adoption: A multi-theoretical perspective, *Information & Management* 45 (2) (2008) 109-119.
- [57] M. Limayem, S.G. Hirt, C.M.K. Cheung, How Habit Limits the Predictive Power of Intention: The Case of Information Systems Continuance, *MIS Quarterly* 31 (4) (2007) 705-738.
- [58] M. Lombard and T. Ditton, At the heart of it all: The concept of presence, *Journal of Computer-Mediated Communication* 3 (2) (1997)
- [59] N.K. Malhotra, S.S. Kim, A. Patil, Common Method Variance in IS Research: A Comparison of Alternative Approaches and a Reanalysis of Past Research, *Management Science* 52 (12) (2006) 1865-1883.
- [60] M. Mäntymäki and J. Salo, Teenagers in social virtual worlds: Continuous use and purchasing behavior in Habbo Hotel, *Computers in Human Behavior* 27 (6) (2011) 2088-2097.
- [61] P.R. Messinger, E. Stroulia, K. Lyons, M. Bone, R. Niu, K. Smirnov, S. Perelgut, Virtual Worlds – Past, Present, and Future: New Directions in Social Computing, *Decision Support Systems* 47 (3) (2009) 204-228.
- [62] D.F. Midgley, Parsimony or Explanation: On the Estimation of Systems Defined by Nonlinear Differential Equations, *Journal of Consumer Research* 10 (4) (1984) 445-448.
- [63] F.F. Nah, B. Eschenbrenner, D. DeWester, Enhancing Brand Equity through Flow and Telepresence: A Comparison of 2D AND 3D Virtual Worlds, *MIS Quarterly* 35 (3) (2011) 731-747.
- [64] S. Nevo, D. Nevo, H. Kim, From recreational applications to workplace technologies: an empirical study of cross-context IS continuance in the case of virtual worlds, *Journal of Information Technology* 27 (1) (2012) 74-86.
- [65] A. Ortiz deGuinea, M.L. Markus, Why Break the Habit of a Lifetime? Rethinking the Roles of Intention, Habit, and Emotion in Continuing Information Technology Use, *MIS Quarterly* 33 (3) (2009) 433-444.
- [66] J.C. Roca, M. Cagné, Understanding e-learning continuance intention in the workplace: A self-determination theory perspective, *Computers in Human Behavior* 24 (4) (2008) 1585-1604.
- [67] E.M. Rogers, *Diffusion of Innovations*, 5th Ed., Free Press, New York, NY, 2003.
- [68] C. Saunders, A.F. Rutkowski, M. van Genuchten, D. Vogel, J.M. Orrego, Virtual Space and Place: Theory and Test, *MIS Quarterly* 35 (4) (2011) 1079-1098.
- [69] A. Schwarz, C. Schwarz, Y. Jung, B. Pérez-Mira, S. Wiley-Patton, Towards an understanding of assimilation in virtual worlds: the 3C approach, *European Journal of Information Systems* 21 (3) (2012) 303-320.
- [70] D.H. Shin, The Evaluation of User Experience of the Virtual World in Relation to Extrinsic and Intrinsic Motivation, *International Journal of Human-Computer Interaction* 25 (6) (2009) 530-553.
- [71] J. Short, *The social psychology of telecommunications*, John Wiley & Sons, London, 1976.

- [72] Ø. Sørøbø, H. Halvari, V.F. Gulli, R. Kristiansen, The role of self-determination theory in explaining teachers' motivation to continue to use e-learning technology, *Computers & Education* 53 (4) (2009) 1177-1187.
- [73] I. Spero, Agents of change: how young consumers are changing the world of marketing, *Qualitative Market Research: An International Journal* 7 (2) (2004) 153-159.
- [74] Sulake Corporation, Habbo - Where else? Sulake Corporation, 2012, <http://www.sulake.com/habbo/?navi=2>, retrieved: September 11th 2012.
- [75] Sulake Corporation, Habbo Hotel and Facebook are now connected, Sulake Corporation, 2009, http://www.sulake.com/press/releases/2009-12-22-Habbo_Hotel_and_Facebook_are_now_connected_.html, retrieved: September 1, 2012.
- [76] S. Taylor, P. Todd, Decomposition and crossover effects in the theory of planned behavior: A study of consumer adoption intentions, *International Journal of Research in Marketing* 12 (2) (1995) 137-155.
- [77] S. Taylor, P.A. Todd, Understanding information technology usage: A test of competing models, *Information Systems Research* 6 (2) (1995) 144-176.
- [78] R.L. Thompson, C.A. Higgins, J.M. Howell, Personal Computing: Toward a Conceptual Model of Utilization, *MIS Quarterly* 15 (1) (1991) 125-143.
- [79] V. Venkatesh, S.A. Brown, A Longitudinal Investigation of Personal Computers in Homes: Adoption Determinants and Emerging Challenges, *MIS Quarterly* 25 (1) (2001) 71-102.
- [80] T. Verhagen, F. Feldberg, B. van den Hooff, S. Meents, J. Merikivi, Understanding users' motivations to engage in virtual worlds: A multipurpose model and empirical testing, *Computers in Human Behavior* 28 (2) (2012) 484-495.
- [81] T. Verhagen, F. Feldberg, B. van den Hooff, S. Meents, J. Merikivi, Satisfaction with virtual worlds: An integrated model of experiential value, *Information & Management* 48 (6) (2011) 201-207.
- [82] L.R. Vijayasarathy, Predicting consumer intentions to use on-line shopping: the case for an augmented technology acceptance model, *Information & Management* 41 (6) (2004) 747-762.
- [83] J. Wu, P. Li, S. Rao, Why they enjoy virtual game worlds? An empirical investigation, *Journal of Electronic Commerce Research* 9 (3) (2008) 219-230.
- [84] Y.C. Yuan, D. Cosley, H.T. Welsler, L. Xia, G. Gay, The Diffusion of a Task Recommendation System to Facilitate Contributions to an Online Community, *Journal of Computer-Mediated Communication* 15 (1) (2009) 32-59.

Research article 4

Merikivi, J. – Verhagen, T. – Feldberg, F. (2012)

Having belief(s) in social virtual worlds: A decomposed approach. *New Media & Society*.

<http://nms.sagepub.com/content/early/2012/11/26/1461444812466719.full.pdf+html>, retrieved 4/26, 2013.

This article has originally been published in *New Media and Society* (NMS). Reprinted with permission from SAGE.

New Media & Society

<http://nms.sagepub.com/>

Having belief(s) in social virtual worlds: A decomposed approach

Jani Merikivi, Tibert Verhagen and Frans Feldberg
New Media Society published online 30 November 2012
DOI: 10.1177/1461444812466719

The online version of this article can be found at:
<http://nms.sagepub.com/content/early/2012/11/26/1461444812466719>

Published by:



<http://www.sagepublications.com>

Additional services and information for *New Media & Society* can be found at:

Email Alerts: <http://nms.sagepub.com/cgi/alerts>

Subscriptions: <http://nms.sagepub.com/subscriptions>

Reprints: <http://www.sagepub.com/journalsReprints.nav>

Permissions: <http://www.sagepub.com/journalsPermissions.nav>

>> [OnlineFirst Version of Record](#) - Nov 30, 2012

[What is This?](#)



Having belief(s) in social virtual worlds: A decomposed approach

new media & society
0(0) 1–21

© The Author(s) 2012

Reprints and permission:

sagepub.co.uk/journalsPermissions.nav

DOI: 10.1177/1461444812466719

nms.sagepub.com



Jani Merikivi

University of Turku, Finland

Tibert Verhagen

VU University Amsterdam, Netherlands

Frans Feldberg

VU University Amsterdam, Netherlands

Abstract

The interest in social virtual worlds with multiple functions has mushroomed during the past few years. The key challenge social virtual worlds face while attempting to anchor and serve the masses is to reflect the core beliefs of their users. As existing research lacks insight into these core beliefs, this study aims to contribute to the existing knowledge base by proposing and testing a model grounded on the decomposed theory of planned behavior. Predicated on the multipurpose nature of social virtual worlds, the model proposes medium-specific attitudinal, normative and control beliefs as determinants of continual use intention. The model is tested with a sample of 2175 users who inhabit Habbo Hotel – one of the largest social virtual worlds in the industry. The results indicate significant though different influences of attitudinal and control beliefs. The most fundamental finding is the irrelevance of normative beliefs, which puts the social character of social virtual worlds into perspective.

Keywords

Attitudinal beliefs, continual use, control beliefs, decomposed theory of planned behavior, normative beliefs, social virtual world

Corresponding author:

Jani Merikivi, Department of Information Systems Science, University of Turku, Rehtoripellonkatu 3, FIN-20500 Turku, Finland.

Email: jjjmer@utu.fi

Introduction

Social virtual worlds (SVWs) refer to three-dimensional, Internet based, immersive massive multi-user environments, wherein participants interact through avatars and perform activities ranging from social interaction to action-oriented gaming under minimum constraints (Jung and Kang, 2010). SVWs such as Habbo Hotel, Poptropica, Club Penguin, Stardolls and Second Life have grown rapidly in popularity. Worldwide, the total number of registered SVW accounts surpassed the 1.7 billion (kZero, 2012). The impressive uplift in SVW usage has received a great deal of attention from the public at large and contributed to the emergence of tens of new SVWs (kZero, 2012). Due to the rise of these new entrants, SVW operators and designers face the challenge of keeping their users' interests alive and facilitate them in such a way that they continue using their SVW after initial adoption (Platoni, 2008).

Remarkably, while numerous SVW studies have been conducted (for literature reviews, see Schwarz et al., 2012; Verhagen et al., 2012), relatively few of them address which medium-specific user beliefs drive SVW continual use intentions. To fill this gap and expand our knowledge on SVW continual use, which refers to post-adoption medium use (as opposed to initial acceptance) (e.g. Karahanna et al., 1999), this paper proposes and tests an integrative model grounded on the decomposed theory of planned behavior (DTPB) (Taylor and Todd, 1995a, 1995b). The DTPB is selected over other theories as it enables us to decompose rather generic beliefs into three belief types that directly tap into the nature of SVWs: beliefs about a person's behavioral feelings towards using a medium (attitudinal beliefs), beliefs about a person's perceptions about using a medium in relation to the opinion and impact of others (normative beliefs), and beliefs about a person's perceptions about the control she has in using a medium (control beliefs) (cf. Fishbein and Ajzen, 2010). Attitudinal beliefs are assumed to influence medium usage in situations where users can voluntarily use a medium for multiple purposes, which directly applies to SVW settings (Verhagen et al., 2012). The relevance of a study into normative beliefs is highlighted by the fact that SVWs are typical social online environments, in which users are literally surrounded by other users. This social nature makes it plausible to assume that normative beliefs may play a role in SVW user behavior (Merikivi, 2009). Also, developing insight into the influence of control beliefs is of interest, as using SVWs demands new navigational skills to use an avatar and navigate through these 3D environments (Verhagen et al., 2011).

The overarching goal of this paper is to apply the DTPB and develop a framework to examine the effects of key attitudinal, normative and control beliefs on SVW continual use. This goal translates into the following key research question: How and to what extent do attitudinal, normative and control beliefs influence SVW continual use? By answering this question, our paper intends to make four contributions. First, we generate new insights into the specific beliefs underlying SVW continual use. Knowledge on this issue is scarce and openly demanded for (Jung and Kang, 2010). Second, drawing upon the nomological structure of DTPB, we propose and test the influence of attitudinal, normative and control beliefs on continual use intentions. This testing counts as a contextual extension (see Berthon et al., 2002) as the DTPB has, to the best of our knowledge, not been applied in SVW settings. Third, we make use of real user data to

estimate and validate our model. As most prior research on SVWs has made use of student sampling (for a review, see Sivunen and Hakonen, 2011), using real users adds to the external validity of our knowledge of the beliefs underlying SVW continual use. Fourth, the gained insights on the relative influence of the examined beliefs aim to assist operators and designers of SVWs to further align the functionality of SVWs to better accommodate the expectations of their users. It also adds to the knowledge of society about why people keep on using SVWs.

Theoretical background

The decomposed theory of planned behavior

To focus explicitly on the role of beliefs behind SVW continual use, this study expands upon the DTPB (Taylor and Todd, 1995a, 1995b). Basically, the DTPB is a modification of the theory of planned behavior (TPB) (Ajzen, 1991). The TPB posits that an individual's behavior is directly driven by behavioral intentions where behavioral intentions are a function of behavioral attitudes, subjective norms, and perceived behavioral control. Behavioral attitudes stand for a person's general feelings of favorableness or unfavorableness toward a behavior (Fishbein and Ajzen, 1975), whereas subjective norms address a "person's perception of the social pressures put on him to perform or not perform the behavior in question" (Ajzen and Fishbein, 1980: 6). Perceived behavioral control concerns "people's perception of the ease or difficulty of performing the behavior of interest" (Ajzen, 1991: 183).

The TPB has been successfully applied to various behavioral settings, including new media technology usage, and the overall results support its predictive and nomological value (De Canniere et al., 2009). Still, the appropriateness of the three behavioral intention determinants has given rise to much debate for the past two decades. In particular Taylor and Todd (1995a, 1995b) highlighted the need for disaggregation of the attitudes, subjective norms, and perceived behavioral control to arrive at a fuller understanding of the beliefs underlying specific media technology usage. This indicates that finding the appropriate set of belief constructs does not necessarily require the adoption of these three generic constructs in a parsimonious structure; rather, it recommends decomposing them into more comprehensive sets of beliefs that directly apply to the specific context of the research setting. From this perspective the terms attitudinal beliefs, normative beliefs and control beliefs are used, each of them referring to the particular concept they are decomposed from. The advantage of the decomposed approach is that it is expected to generate a fuller understanding of the appropriate set of beliefs underlying the usage of a particular media technology (Taylor and Todd, 1995a, 1995b).

Previous research on SVW continual use

To qualify the decomposed approach founded on theoretical rationale and to identify the attitudinal, normative, and control beliefs driving continual SVW use, we conducted a context-centric review of the existing literature relevant to our topic. Using four scientific databases (ABI/INFORM, PsycINFO, ScienceDirect and Wiley) covering disciplines

such as information systems, computer science, marketing, and social psychology, a total of around 700 studies were found for the search terms “virtual world”, “online game” and “online world” (abstract, title key words). Sixty-three studies concerned empirical examinations of a multitude of user behaviors and were therefore selected as relevant to preliminary assessment. Since 50 of these studies examined behavior other than continual use we decided to exclude them from further analysis. This resulted in a pool of 13 studies, which is summarized in Table 1.

As reflected in the number of studies listed, relatively little research exists on continual SVW use (see also Jung, 2011). Much of the research that does fall within this

Table 1. Empirical studies on continual virtual world use.

Author(s)	Focus	Theoretical framework	Beliefs studied	Sample	Key findings
Lu and Wang (2008)	Exploring the extent to which addiction and satisfaction influence loyalty towards online games	Exploratory approach	Control beliefs, normative beliefs, perceived playfulness	1186 players using various online games	Satisfaction contributes to loyalty more than addiction
Yang et al. (2009)	Assessing the factors antecedent satisfaction and loyalty towards online games	Technology acceptance model	Experiential value, transaction cost, service quality	877 players using various online games	Service quality and transaction cost support loyalty indirectly
Teng (2010)	Investigating how customization, immersion satisfaction, and gamer loyalty are related within online games	Reinforcement theory	Customization and immersion satisfaction	865 players using various online games	Customization and immersion satisfaction promote loyalty
Barnes (2011)	Examining the reasons why people continue using SVWs	Instant activation perspective; habit/automaticity perspective	Perceived usefulness, enjoyment, habit	339 users of Second Life	Continual use is driven by perceived usefulness, enjoyment, habit, and instant activation
Goel et al. (2011)	Investigating factors that predict continual SVW use	Interactionist theory of place attachment	Cognitive absorption	199 students using Second Life	Continual use is determined by a state of deep involvement
Huang and Hsieh (2011)	Exploring the factors affecting consumer loyalty towards online games	Uses and gratifications theory; theory of flow	Entertainment, sociality, challenge, control, interactivity	126 interviews and 126 questionnaires of players using various online games	Players' sense of control, perceived entertainment, and challenge affect loyalty

Table 1. (Continued)

Author(s)	Focus	Theoretical framework	Beliefs studied	Sample	Key findings
Jung (2011)	Identifying the factors that influence continual SVW use	Expectation-disconfirmation theory	Telepresence, social presence, and perceived autonomy	194 users of Second Life	Continual use is determined by the sense of presence and perceived autonomy
Mäntymäki and Salo (2011)	Examining the drivers that influence continual SVW use	Technology acceptance model	Enjoyment, perceived aggregate network exposure, perceived usefulness, perceived ease of use	2481 users of Habbo Hotel	Perceived enjoyment and usefulness affects continual use
Nevo et al. (2012)	Exploring the cross-contextual use of VVs	Exploratory approach	Recreational, work usage, cognitive absorption	203 professionals involved in VVs	Through cognitive absorption, recreational usage promotes work usage intentions
Schwarz et al. (2012)	Explaining SVW assimilation	Theory of reasoned action	Ease of use, playfulness, social presence, self-distraction	223 users of Second Life	Technology and community class of factors influence intention via attitude towards VVs
Teng et al. (2012)	Investigating relationships among gaming challenge, interdependence and gamer loyalty within online games	Interdependence theory; bilateral deterrence theory	Challenge, interdependence, loyalty	994 players using various online games	Gaming challenge influences gamer loyalty directly and via interdependence
Lee and Tsai (2010)	Examining why people continue to play online games	Technology acceptance model; theory of planned behavior	Flow, perceived ease of use, perceived enjoyment	415 online game players	Attitudes, subjective norms, behavioral control flow and enjoyment influence continual use intention
Hsiao and Chiou (2012)	Exploring how network centrality influences continuance intention	Social capital theory	Perceived network centrality, non-guild interaction, perceived enjoyment, access to resources	347 players of World of Warcraft	Access to resources lead to game continuance

SVW: Social Virtual World; VV: Virtual World

domain centers on concepts such as satisfaction (Teng, 2010), gaming addiction (Lu and Wang, 2008) or purchasing behavior (Mäntymäki and Salo, 2011), with only a few studies focusing on continual use intentions (Barnes, 2011; Goel et al., 2011). Furthermore, while numerous beliefs were studied, only a limited number of studies focused on beliefs that fall within the attitudinal normative of control domain. Those that do (e.g. Goel et al., 2011; Schwarz et al., 2012) only seem to focus on one of these belief types, which leaves their relative importance unaddressed. Moreover, while the available studies have adopted a multitude of diverging theoretical perspectives, the DTPB has not yet been included in the empirical discourse. We decided to adopt the DTPB as a theoretical anchor, as its nomological structure includes three types of beliefs (attitudinal, normative, control) deemed important in continual new media use (Huang and Hsieh, 2011; Mäntymäki and Salo, 2011).

Research model and hypotheses

Figure 1 shows the research model proposed. Drawing upon DTPB, the key dependent construct is continual use intention; whereas attitudinal, normative and control beliefs complete the model as intention determinants.

Perceived enjoyment and perceived usefulness were included as attitudinal beliefs. Both are rooted into the well-known distinction between intrinsic (perceived enjoyment) and extrinsic (perceived usefulness) beliefs behind new media usage (e.g. Barnes, 2011;

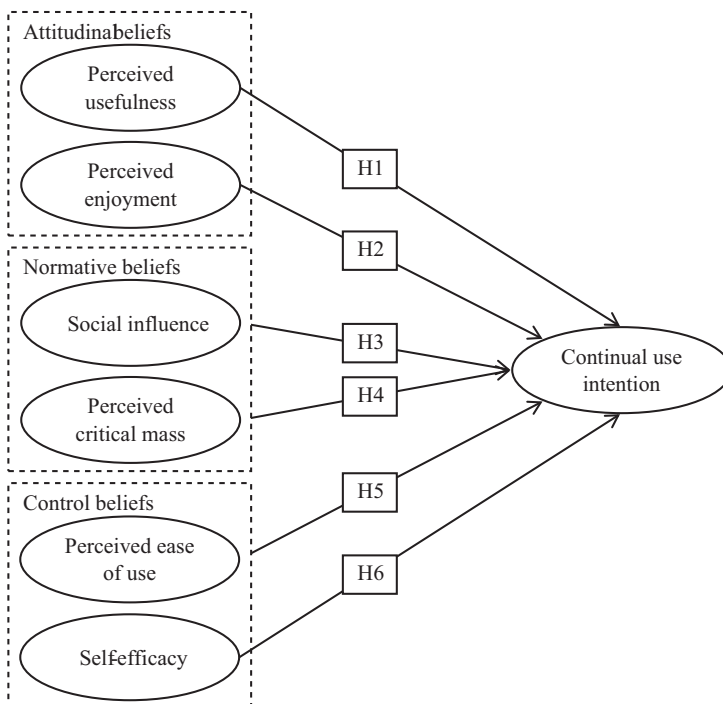

Figure 1. Research model.

Mäntymäki and Salo, 2011). Given the multi-purpose nature of SVWs, this makes it very interesting to cross-validate their (relative) influence on behavior. Social influence and perceived critical mass were proposed as normative beliefs. SVWs are social online environments, in which users are literally surrounded by other users. Both proposed beliefs address prominent social pressures associated with using SVWs (Mäntymäki and Salo, 2011), but have not previously been investigated in such combination. Finally, perceived ease of use and self-efficacy were included as typical control beliefs. These particular beliefs seem closely associated with the new navigational skills required to make use of avatars to move inside SVWs (Verhagen et al., 2012). This makes it highly likely that both influence behavior in SVW settings.

Following Premkumar et al. (2008), we directly relate the different beliefs to the continual use intention. Such an approach differs slightly from more traditional DTPB modeling as it removes the attitude, subjective norms and perceived behavioral control as mediators between the decomposed beliefs and the continual use intention. This more direct approach is advocated by Stutzman and Green (1982), who noted that the traditional relationship beliefs → attitude/subjective norms → intention → behavior is appropriate for simple behaviors, analogous to a single act criterion. For multiple act criteria and more complex behaviors, however, one needs to take a more complex view of the model by linking variables more directly to behavior. Support for this view is provided by literature that found rather direct effects of beliefs on various forms of behavior (Bagozzi, 1981; Fisher, 1984).

Attitudinal beliefs

Drawing upon motivation theory (e.g. Ryan and Deci, 2000a, 2000b), attitudinal beliefs in media technology research have predominantly been regulated by two types of beliefs, namely extrinsic and intrinsic (Venkatesh and Brown, 2001). Extrinsic beliefs propel individuals to achieve a specific outcome (e.g. reward, recognition), whereas intrinsic beliefs drive them to engage in activities for their own sake (e.g. pleasure, joy, or satisfaction) (Ryan and Deci, 2000a). Following prior literature (e.g. Davis et al., 1992; Hsieh et al., 2008), attitudinal beliefs are decomposed into the intrinsic belief perceived enjoyment and the extrinsic belief perceived usefulness. Although perceived usefulness is a less frequently reported belief in the SVW literature, both elements directly apply to SVWs given the combination of instantaneous pleasure and the more instrumental values these online environments provide (Barnes, 2011; Mäntymäki and Salo, 2011).

Perceived usefulness refers the degree to which a medium is perceived to provide certain benefits when performing certain tasks (Davis, 1989; Hong et al., 2006). Performing tasks such as virtual learning and training underlines the instrumental value of SVWs. Another element of the usefulness of SVWs is that SVWs offer their users a new medium to express their identity, status, and uniqueness. Individuals explore their identities with and within SVWs (Gunkel, 2010) and differentiate themselves from others through consumption and sale of virtual items (Lehdonvirta, 2009). They may also use avatars to communicate in an appearance different from their offline appearance, expressing themselves in a way others may find provoking, and transcending perceived offline social norms (Vasalou et al., 2008).

Given the above, and the results of Barnes's (2011) study, it is safe to assume that the overall instrumental value of an SVW contributes to a user's willingness to use SVWs. As a result, we hypothesize that:

H1: Perceived usefulness positively influences the SVW continual use intention.

The importance of perceived enjoyment has widely been addressed in online game research (e.g. Hsiao and Chiou, 2012), where it has been defined as the extent to which using the medium is "perceived to be enjoyable in its own right, apart from any performance consequences that may be anticipated" (Davis et al., 1992: 1113). Echoing Holbrook et al. (1984), perceived enjoyment is regarded as the chief constituent of play. The accumulated literature suggests that perceived enjoyment may apply directly to SVWs since motivation to use these online environments arises from play and enjoyment – especially when the users have nothing else to do (Ryan et al., 2006). As a result, we follow Van der Heijden (2003) and propose that perceived enjoyment directly influences the continual use of SVWs.

H2: Perceived enjoyment positively influences the SVW continual use intention.

Normative beliefs

To decompose normative beliefs we follow Taylor and Todd (1995a, 1995b), and draw upon innovation diffusion theory (IDT) (Rogers, 2003). According to IDT, initial users of a new form of technology gather information about the advantages and disadvantages of this technology through the opinions of individuals, informal groups, organizations and other social subsystems. By making use of such social networks, which results in information perceived relevant to the user both in terms of quality and quantity, users' behavioral intentions to use the technology are shaped (Rogers, 2003). To deal with the qualitative and quantitative aspects of SVW use we decompose normative beliefs into social influence (Venkatesh, 2003) and perceived critical mass (Lou et al., 2000; Valente, 1995; Van Slyke et al., 2007) respectively. These two elements are of particular interest from a normative social media technology perspective since they reflect social pressure exerted by peers to use a medium to strengthen existing social relationships or to add to and benefit from the network externalities of a medium (Matei and Ball-Rokeach, 2001).

The decision of an individual whether (or not) to use a new media technology is influenced by the opinions of important others such as family, friends and relatives (Ajzen, 2005). This so-called social influence refers to the degree to which an individual perceives that important others believe he or she should use the new media technology (Venkatesh, 2003). Social influence is assumed to play a role in the formation of behavioral intentions in SVW settings for several reasons. First, in game-like environments it is well-conceivable that close peers are enthusiastic about using the medium as it provides entertainment value (Verhagen et al., 2011). In such situations, peers most likely will encourage and persuade others to join them (Hau and Kim, 2011). Second, the behavior underlying SVW usage is to a large extent social and networked in nature. In such a setting social interactions are a major activity, which makes it plausible to assume

that the willingness of an individual to use the SVW is at least to some extent driven by social influences (Dholakia et al., 2004). Given the above, this leads us to propose that:

H3: Social influence positively influences the SVW continual use intention.

While the concept of social influence captures the qualitative aspect of social influence, it ignores the quantitative side highlighted by perceived network exposure, meaning that the amount of influence tends to gain strength as the number of the sources increases (Latané, 1981). In the media technology literature, this phenomenon is known as critical mass, which is defined as the point at which a further rate of adoption of an innovation becomes self-sustaining (Markus, 1990). This is due to the collective force of the increasing number of users who legitimize the use of SVWs by making it more and more attractive and valuable to everyone (Li et al., 2005; Lou et al., 2000). For instance, the experience in SVWs depends much on user-created content (Kohler et al., 2011), and without critical mass there would not be enough content for users to experience and consume.

Given that it would be difficult to accurately determine the level of the actual critical mass we follow Lou et al. (2000) and Sledgianowski and Kulviwat (2009), who address the importance of subjective perceptions of critical mass (see also Van Slyke et al., 2007). Perceived critical mass relates to the extent to which an individual perceives a significant number of members in his/her network are using a certain innovation (Lou et al., 2000; Sledgianowski and Kulviwat, 2009). In line with research on perceived network exposure (Hsieh et al., 2008; Mäntymäki and Salo, 2011), it is plausible to assume that a higher perceived critical mass contributes to an individual's intention to continue using the technology. Such a direct relationship is most likely to occur when considering media technologies, the use of which is subject to social pressure (Strader et al., 2007), a situation that clearly applies to SVWs. As a result, we expect that:

H4: Perceived critical mass positively influences the continual use intention.

Control beliefs

In line with the original DTPB we draw upon social cognitive theory (SCT) (Bandura, 2001) to embed and decompose perceived behavioral control into its underlying control beliefs. Basically, SCT posits a triadic reciprocal relationship between behavior, personal factors, and the environment. In other words, an individual's behavior both influences and is influenced by personal factors and the environment. Such presumption of an individual having the ability to influence his/her behavior, while at the same time recognizing that his/her behavior is influenced by personal factors and the environment, is consistent with that of perceived behavioral control, which concerns personal perceptions of an individual's ability to perform a given behavior (Ajzen, 2002). From this perspective, and drawing upon previous empirical evidence (Hsieh et al., 2008), we decompose perceived behavioral control into perceived ease of use and self-efficacy.

Perceived ease of use is defined here as the degree to which a person believes he/she can use media technology free of effort (Davis, 1989). Perceived ease of use deals with

one of the most fundamental constructs determining new media usage in various settings (Hong et al., 2006), and has been acknowledged to directly influence behavioral intentions (Davis, 1989). In SVW settings the concept demands renewed attention, as the usage of an avatar is a relatively new way of computer-mediated navigation, which demands new skills to control the medium. Supported by an earlier study (Ajzen, 2005), we position the concept as a control belief as it mirrors an individual's capability to handle the complexity of the control of a medium. In line with the above, and recent empirical evidence in online gaming and SVW contexts (Huang and Hsieh, 2011), it is conceivable to assume that the ease with which an individual is able to use an avatar and interact with and within an SVW is essential in developing a positive intention to continue using an SVW. Therefore, we postulate:

H5: Perceived ease of use positively influences the SVW continual use intention.

Self-efficacy equals the degree of self-confidence an individual has about his/her capability to execute a behavior (Bandura, 2001). While the construct may be seen from a rather general trait-oriented perspective, we adopt a more medium-specific perspective (cf. Agarwal et al., 2000). As such, it accounts for the varying effects of other users on the individual's ability to perform a particular behavior.

The fact that users of SVWs are constantly observed by and confronted with others when performing a target behavior puts the concept of self-efficacy in a renewed perspective. Not only may the confrontation with other users' observations exert social pressure on their self-confidence to perform the behavior in question, but the users may even feel that it may be hampered by the actions of other users (e.g. losing a game because of other users' actions; being unable to purchase digital furniture as others already have them). These social characteristics make it plausible to believe that self-efficacy influences behavioral intentions in SVW settings. Moreover, in prior research there is a relative consensus that the higher the level of self-efficacy an individual has towards performing a certain behavior, the more likely it is that he/she intends to engage in it (Graham and Beverley, 2002). The above justifications and empirical support lead us to propose that:

H6: Self-efficacy positively influences the SVW continual use intention.

Method and results

Data collection

A survey design was adopted to collect empirical data and test the hypotheses. The sample consisted of users of the Finnish portal of the teenager-oriented SVW Habbo Hotel, which provides free access to over 30 country-specific portals with a number of public facilities such as virtual parks and cafés, and millions of user-generated private virtual rooms. Users communicate with one another and play various in-world games through an avatar. The users may control the way their avatars look, walk, talk, and dance, and purchase credits in order to create and furnish their very own personal virtual rooms.

Research design and measures

The survey was published on the home page of the portal; participation involved clicking on a hyperlink leading to an online survey. As no incentive of any kind was offered, the probability of conditioning due to a participation bias was considered low. All measures were derived from established and validated measurement scales (see Appendix 1).

Before publishing the survey, a pilot test was conducted using over 2000 Canadian Habbo users who were asked to evaluate the linguistic intelligibility of the survey and to propose improvements. Some minor modifications were made. Then, the survey was translated into the language in which it was to be administered (i.e. Finnish) by two new media researchers, whose native language is Finnish. The survey was then double-checked by a professional translator. Bearing in mind that the respondents were teenagers, no identifiable personal information such as user names was collected.

Results

A total of 2175 respondents filled out the survey completely. The majority of the respondents was female ($n=1289$; 59.3%), and between 10 and 15 years old ($n=1836$; 84.4%); 833 (38.3%) respondents reported using Habbo Hotel for between one and three years, while 933 (42.9%) respondents indicated using Habbo Hotel for three years or more. This implies that our sample was biased towards young, mostly female, rather experienced Habbo Hotel users. To investigate whether non-response bias posed a threat to the internal validity of the study, we compared the sample demographics with those of the population of Finnish Habbo users. A comparison with the available user survey (Habbo Hotel, 2008) indicated no large demographical discrepancies.

PLS was used to assess the validity and reliability of the measures. We utilized the software package Smart PLS (Ringle et al., 2005) to compute factor loadings, Cronbach's alpha, composite reliability and Average Variance Extracted (AVE). The results (Table 2) indicated convergent validity of all measures as the factor loadings exceeded the 0.70 criterion, the alphas surpassed the 0.80 level, the composite reliability scores exceeded the recommended level of 0.70, and the AVE-scores surpassed the recommended level of 0.50 (Ping, 2004).

Next, we assessed the discriminant validity of the measures by studying the within-construct item loadings and comparing these to across-construct item loadings. Since all within-construct item loadings were high, and substantially lower than their cross-loadings, discriminant validity could be assumed. Supplementary support for discriminant validity was provided by a study of the squared correlations between the constructs and a comparison of these scores with the individual AVEs (Table 3). For each pair, both individual AVEs exceeded the value of the squared correlations, confirming discriminant validity.

Finally, we assessed the reliability of the scales. The results strongly confirmed the reliability of the measures. All Cronbach's alphas and composite reliability scores exceeded the advocated values of 0.80. Moreover, all AVEs surpassed the 0.50 guideline for reliability (Ping, 2004).

Table 2. Validity and reliability statistics.

Construct (no. of items)	Factor loadings	Cronbach's alpha	Composite reliability	AVE
Perceived usefulness (3)	0.887; 0.884;0.894	0.867	0.918	0.789
Perceived enjoyment (3)	0.924; 0.950;0.950	0.936	0.959	0.886
Social influence (3)	0.919; 0.930;0.881	0.898	0.936	0.829
Perceived critical mass (3)	0.886; 0.906;0.867	0.865	0.917	0.786
Perceived ease of use (4)	0.924; 0.939;0.907; 0.889	0.935	0.954	0.837
Self-efficacy (3)	0.939; 0.948;0.944	0.938	0.961	0.890
Continual intention (3)	0.927; 0.951; 0.939	0.933	0.957	0.882

AVE: Average Variance Extracted

Table 3. Squared pairwise correlation.

Construct	Perceived usefulness	Perceived enjoyment	Social influence	Perceived critical mass	Perceived ease of use	Self-efficacy	Continual use intention
Perceived usefulness	0.789						
Perceived enjoyment	0.790	0.886					
Social Influence	0.510	0.469	0.829				
Perceived critical mass	0.506	0.448	0.673	0.786			
Perceived ease of use	0.483	0.543	0.252	0.306	0.837		
Self-efficacy	0.315	0.375	0.141	0.199	0.723	0.890	
Continual use intention	0.597	0.669	0.361	0.398	0.583	0.494	0.882

Note. The bold scores (diagonal) are the AVEs of the individual constructs. Off-diagonal scores are the squared correlations between the constructs.

AVE: Average Variance Extracted

PLS modeling was applied to validate the structural model and test the hypotheses (Gefen et al., 2000). Given our focus on predicting and attributing variances to the continual use without having too much knowledge on the possible outcome structures derived from previous publications, PLS was deemed a feasible method (Fornell and Bookstein, 1982). We applied the bootstrapping technique (500 re-samples) to estimate the standardized path coefficients and explained variances. Two-tailed *t*-tests were conducted to assess the significance of the path effects. Overall, the results strongly confirm the predictive power of the model. The amount of variance explained was rather high, implying a good fit to the data. Except for hypothesis 3, all hypotheses were supported.

Table 4. Summary of the hypotheses testing results.

Hypothesis	Path	β	T-Statistics	Sign.	Result
1	Perceived usefulness → continual use intention	0.12	3.745	< .001	Supported
2	Perceived enjoyment → continual use intention	0.38	11.534	< .001	Supported
3	Social Influence → continual use intention	0.00	0.019	N.S.	Rejected
4	Perceived critical mass → continual use intention	0.08	3.500	< .001	Supported
5	Perceived ease of use → continual use intention	0.16	5.415	< .001	Supported
6	Self-efficacy → continual use intention	0.18	6.521	< .001	Supported

Note. All expected relationships are positive in nature.
N.S.: non-significant

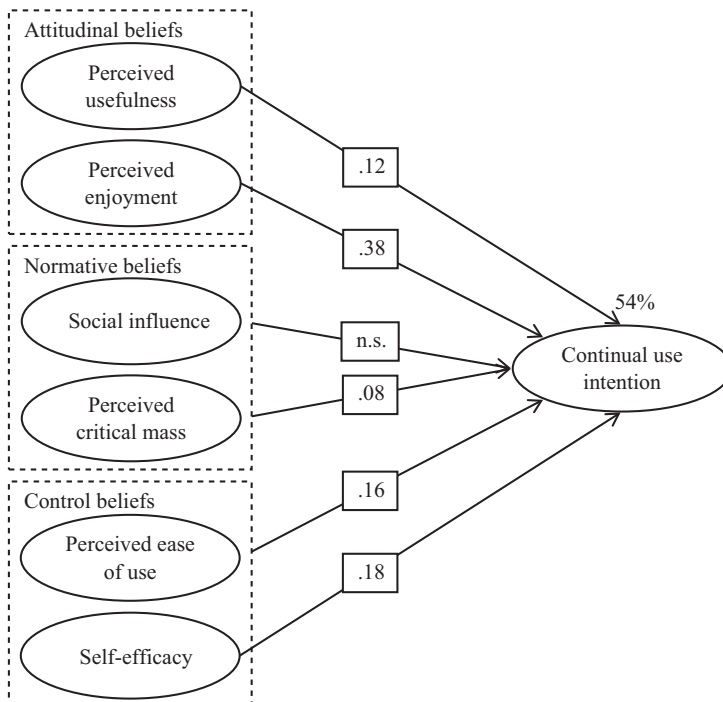

Figure 2. Structural model of the study.

Note: "54%" corresponds to the percentage of the variance in the continual use intention the proposed beliefs in our model explain.

Discussion

Key findings

Together, the beliefs in our model explained 54% of the variance in the continual use intention. The intention was determined strongly by enjoyment ($\beta = 0.38$), rather moderately by self-efficacy ($\beta = 0.18$), ease of use and usefulness (both: $\beta = 0.12$). Remarkably, the influence of perceived critical mass on the continual use intention was trivial ($\beta = 0.08$), while social influence had no significant effect at all. In sum, our findings indicate that SVWs are likely to anchor users who personally perceive the medium to deliver enjoyment and usefulness while reinforcing the feeling of being in control.

Implications for theory and practice

The findings of this study have several theoretical implications. First, an approach to how attitudinal, normative, and control beliefs jointly influence behavior in SVWs has remained an open question. We examined this issue empirically and demonstrated that attitudinal and control beliefs are the pivotal structures underlying the formation of SVW continual use intentions. Second, by identifying the individual key beliefs behind continual use intentions our study has enhanced theoretical knowledge of developing behavioral frameworks built upon DTPB. Not only do the proposed decomposed beliefs demonstrate the value of the theory when delineating the key beliefs underlying specific behavior, but they also embody a test of a DTPB structure in SVW settings. Such contextual extension should be seen as test of theoretical effectiveness as it adds to the generalizability of the DTPB (Berthon et al., 2002). Third, the fact that our findings confirmed direct influences of the different beliefs on continual use intentions puts the original structure of the DTPB into perspective. In the original DTPB the attitude, subjective norms and perceived behavioral control are included as mediators between the decomposed beliefs and the continual use intention. If these mediators do not fully mediate the relationships, their inclusion seems to hold less value (Chin, 1998). Our findings advocate more direct approaches in SVW settings (cf. Merikivi, 2009), as behavior in the SVW as a multipurpose medium is more diversified and complex in nature. In such situations, context-specific constructs rather than more global constructs have been demonstrated to explain behavioral intentions in a rather direct way (Hong and Tam, 2006).

From a practical point of view the findings yield interesting implications for improving the long-term user experience. First, the relatively high impact of enjoyment adds to the notion that the SVWs' young users continually advocate the game-like, rather pleasure-oriented nature over utility (cf. Barnes, 2011; Mäntymäki and Salo, 2011). This is not to advocate neglecting instrumental features completely (e.g. communicating with peers or expressing oneself) (Shin, 2009), however, as previous research has demonstrated that instrumental value may influence the use of SVWs through enjoyment (Verhagen et al., 2012). Still, when prioritizing user-centered developments, generating enjoyable experiences should be the first point of attention. Second, our counterintuitive findings on the influence of normative beliefs point out that while in their pre-teens and teens, the

respondents aim for individual freedom. Instead of adjusting their behavior to their referents' views, the users wish to make decisions on their own (Palan et al., 2010). Hence, anyone willing to influence behavior of SVW users, such as operators of SVWs and parents of SVW users, must be aware of the fact that friends and relatives only seem to play a minor role in this context. Third, while surrounded by countless avatars, SVW users hardly seem to perceive the benefits of critical mass. Operators and designers of SVWs may take this finding into account, for example, by communicating more clearly the growth of the user community and the increase in digital content, and by providing their users with more social tools to search for and expand the number of in-world friends (Mäntymäki and Salo, 2011). Fourth, our findings underline the value of paying attention to characteristics that determine the control and representation of avatars. This is because SVW users navigate, communicate and express themselves in the SVW environment through avatars. In line with previous SVW research (Huang and Hsieh, 2011), we therefore encourage the further development of avatar features that increase the usability of SVWs, as well as those that elevate the level of self-efficacy of their users.

Limitations and future research

This study has been subject to a number of limitations. First, our sample consisted of young respondents living in Western culture. The bias towards young people implies that one should be cautious when extrapolating our findings to other age groups. In addition, as previous research has shown that culture is likely to affect the extent to which media technology perceptions influence user behavior (e.g. Al-Gahtani et al., 2007), cross-cultural validation seems needed. Second, the data collection was restricted to one SVW. While Habbo Hotel is one of the most popular SVWs worldwide, our research findings may not be fully generalizable. We encourage researchers to cross-validate our findings with other SVWs. Third, the gender bias towards young women in our sample may have influenced our findings. For example, the influence of skills on exploratory behavior is assumed to be stronger for women than for men, and women also tend to rely more on enjoyment and less on usefulness when performing particular tasks (Richard et al., 2010). A line of future inquiry could address these issues. Fourth, the model has been validated by making use of scales initially designed for use with adults. Some caution may be required when extrapolating our findings. Fifth, while the predictive validity of our model was more than acceptable, the decomposed beliefs in the model were by no means meant to be complete. This offers opportunities for future extensions and refinements.

Conclusion

By applying the DTPB, this study has examined why young people continue using SVWs. Specifically, we investigated SVW-sensitive attitudinal, normative and control beliefs influencing users' continual use intention. While SVWs are multi-purpose and crowded by other users, our findings indicate that young people may keep using them mostly for their own personal enjoyment and are relatively insensitive to the presence and opinions of others. Due to the newness of SVWs in terms of navigability, importance is also attached to the ease of controlling the SVW system. Overall, we demonstrated that

making SVWs more enjoyable without jeopardizing the feeling of being in control is key in enhancing their long-time value among their users.

Acknowledgements

The authors would like to state their gratitude to Dr Matti Mäntymäki; the European Commission; Finnish Youth Research Society; Turku Centre for Computer Science; Sulake Corporation; and Novay, the Dutch consortium on IT and open innovation; for assistance in conducting this study.

Funding

This research received no specific grant from any funding agency in the public, commercial or not-for-profits sectors.

References

- Agarwal R, Sambamurthy V and Ralph MS (2000) Research report: The evolving relationship between general and specific computer self-efficacy – an empirical assessment. *Information Systems Research* 11(4): 418–430.
- Ajzen I (1991) The theory of planned behavior. *Organizational Behavior and Human Decision Processes* 50(2): 179–211.
- Ajzen I (2002) Perceived behavioral control, self-efficacy, locus of control, and the theory of planned behavior. *Journal of Applied Social Psychology* 32(4): 665–683.
- Ajzen I (2005) *Attitudes, Personality, and Behavior*. Maidenhead: Open University Press.
- Ajzen I and Fishbein M (1980) *Understanding Attitudes and Predicting Social Behavior*. Englewood Cliffs, NJ: Prentice Hall.
- Ajzen I and Madden TJ (1986) Prediction of goal-directed behavior: Attitudes, intentions, and perceived behavioral control. *Journal of Experimental Social Psychology* 22(5): 453–474.
- Al-Gahtani SS, Hubona GS and Wang J (2007) Information technology (IT) in Saudi Arabia: Culture and the acceptance and use of IT. *Information & Management* 44(8): 681–691.
- Bagozzi RP (1981) Attitudes, intentions, and behavior: A test of some key hypotheses. *Journal of Personality and Social Psychology* 41(4): 607–627.
- Bandura A (2001) Social cognitive theory of mass communication. *Media Psychology* 3(3): 265–299.
- Barnes SJ (2011) Understanding use continuance in virtual worlds: Empirical test of a research model. *Information & Management* 48(8): 313–319.
- Berthon P, Pitt L, Ewing M, et al. (2002) Potential research space in MIS: A framework for envisioning and evaluating research replication, extension, and generation. *Information Systems Research* 13(4): 416–427.
- Chin WW (1998) Issues and opinion on structural equation modeling. *MIS Quarterly* 22(1): 7–15.
- Compeau DR and Higgins CA (1995) Computer self-efficacy: Development of a measure and initial test. *MIS Quarterly* 19(2): 189–211.
- Davis FD (1989) Perceived usefulness, perceived ease of use, and user acceptance of information technology. *MIS Quarterly* 13(3): 319–340.
- Davis FD, Bagozzi RP and Warshaw PR (1989) User acceptance of computer technology: A comparison of two theoretical models. *Management Science* 35(8): 982–1003.
- Davis FD, Bagozzi RP and Warshaw PR (1992) Extrinsic and intrinsic motivation to use computers in the workplace. *Journal of Applied Social Psychology* 22(14): 1111–1132.

- De Canniere MH, De Pelsmacker P and Geuens M (2009) Relationship quality and the theory of planned behavior models of behavioral intentions and purchase behavior. *Journal of Business Research* 62(1): 82–92.
- Dholakia UM, Bagozzi RP and Pearo LK (2004) A social influence model of consumer participation in network- and small-group-based virtual communities. *International Journal of Research in Marketing* 21(3): 241–263.
- Fishbein M and Ajzen I (1975) *Belief, Attitude, Intention and Behavior: An Introduction to Theory and Research*. Reading, MA: Addison-Wesley.
- Fishbein M and Ajzen I (2010) *Predicting and Changing Behavior: The Reasoned Action Approach*. New York: Psychology Press.
- Fisher WA (1984) Predicting contraceptive behavior among university men: The role of emotions and behavioral intentions. *Journal of Applied Social Psychology* 14(2): 104–123.
- Fornell C and Bookstein FL (1982) Two structural equation models: LISREL and PLS applied to consumer exit-voice theory. *Journal of Marketing Research* 19(4): 440–452.
- Gefen D, Straub DW and Boudreau M (2000) Structural equation modeling and regression: Guidelines for research practice. *Communications of the Association for Information Systems* 4(7): 1–78.
- Goel L, Johnson NA, Junglas I, et al. (2011) From space to place: Predicting users' intentions to return to virtual worlds. *MIS Quarterly* 35(3): 749–771.
- Graham LB and Beverley AS (2002) Service locus of control: Its conceptualization and measurement. *Journal of Service Research* 4(4): 312–324.
- Gunkel DJ (2010) The real problem: Avatars, metaphysics and online social interaction. *New Media & Society* 12(1): 127–141.
- Habbo Hotel (2008) *Global Habbo Youth Survey*. Helsinki: 15/30 Research.
- Hau YS and Kim Y (2011) Why would online gamers share their innovation-conducive knowledge in the online game user community? Integrating individual motivations and social capital perspectives. *Computers in Human Behavior* 27(2): 956–970.
- Holbrook MB, Chestnut RW, Terence AO, et al. (1984) Play as a consumption experience: The roles of emotions, performance, and personality in the enjoyment of games. *Journal of Consumer Research* 11(2): 728–739.
- Hong S and Tam KY (2006) Understanding the adoption of multipurpose information appliances: The case of mobile data services. *Information Systems Research* 17(2): 162–179.
- Hong S, Thong JYL and Tam KY (2006) Understanding continued information technology usage behavior: A comparison of three models in the context of mobile Internet. *Decision Support Systems* 42(3): 1819–1834.
- Hsiao C and Chiou J (2012) The effects of a player's network centrality on resource accessibility, game enjoyment, and continuance intention: A study on online gaming communities. *Electronic Commerce Research and Applications* 11(1): 75–84.
- Hsieh JJP, Rai A and Keil M (2008) Understanding digital inequality: Comparing continued use behavioral models of the socio-economically advantaged and disadvantaged. *MIS Quarterly* 32(1): 97–126.
- Huang L and Hsieh Y (2011) Predicting online game loyalty based on need gratification and experiential motives. *Internet Research* 21(5): 581–598.
- Jung Y (2011) Understanding the role of sense of presence and perceived autonomy in users' continued use of social virtual worlds. *Journal of Computer-Mediated Communication* 16(4): 492–510.
- Jung Y and Kang H (2010) User goals in social virtual worlds: A means-end chain approach. *Computers in Human Behavior* 26(2): 218–225.
- Karahanna E, Straub DW and Chervany NL (1999) Information technology adoption across time: A cross-sectional comparison of pre-adoption and post-adoption beliefs. *MIS Quarterly* 23(2): 183–213.

- Kohler T, Fueller J, Matzler K, et al. (2011) Co-creation in virtual worlds: The design of the user experience. *MIS Quarterly* 35(3): 773–788.
- kZero (2012) Latest news. Available at: <http://www.kzero.co.uk/blog/> (accessed 21 February 2012).
- Latané B (1981) The psychology of social impact. *American Psychologist* 36(4): 343–356.
- Lee M and Tsai T (2010) What drives people to continue to play online games? An extension of technology model and theory of planned behavior. *International Journal of Human-Computer Interaction* 26(6): 601–620.
- Lehdonvirta V (2009) Virtual items sales as a revenue model: Identifying attributes that drive purchase decisions. *Electronic Commerce Research* 9(1–2): 97–113.
- Li D, Chau PYK and Lou H (2005) Understanding individual adoption of instant messaging: An empirical investigation. *Journal of the Association for Information Systems* 6(4): 102–129.
- Lou H, Luo W and Strong D (2000) Perceived critical mass effect on groupware acceptance. *European Journal of Information Systems* 9(2): 91–103.
- Lu H and Wang S (2008) The role of Internet addiction in online game loyalty: An exploratory study. *Internet Research* 18(5): 499–519.
- Mäntymäki M and Salo J (2011) Teenagers in social virtual worlds: Continuous use and purchasing behavior in Habbo Hotel. *Computers in Human Behavior* 27(6): 2088–2097.
- Markus ML (1990) Toward a ‘Critical mass’ theory of interactive media: Universal access, interdependence and diffusion. In: Fulk J and Steinfield C (eds) *Organizations and Communication Technology*. Newbury Park, CA: SAGE, pp. 194–218.
- Matei S and Ball-Rokeach S (2001) Real and virtual social ties: Connections in the everyday lives of seven ethnic neighborhoods. *American Behavioral Scientist* 45(3): 550–564.
- Merikivi J (2009) What Habbo goes do in practice? Decomposing attitudinal beliefs. In: *Proceedings of the 17th European Conference on Information Systems*, Verona, Italy, 8–10 June 2009. Available at: <http://www.ecis2009.it/papers/ecis2009-0465.pdf> (accessed 10 October 2012).
- Nevo S, Nevo D and Kim H (2012) From recreational applications to workplace technologies: An empirical study of cross-context IS continuance in the case of virtual worlds. *Journal of Information Technology* 27(1): 74–86.
- Palan KM, Gentina E and Muratore I (2010) Adolescent consumption autonomy: A cross-cultural examination. *Journal of Business Research* 63(12): 1342–1348.
- Ping RAJ (2004) On assuring valid measures for theoretical models using survey data. *Journal of Business Research* 57(2): 125–141.
- Platoni K (2008) Will second life survive? Available at: <http://alumni.berkeley.edu/news/california-magazine/marchapril-2008-mind-matters/will-second-life-survive> (accessed 11 November 2011).
- Premkumar G, Ramamurthy K and Liu H (2008) Internet messaging: An examination of the impact of attitudinal, normative, and control belief systems. *Information & Management* 45(7): 451–457.
- Richard M, Chebat J, Yang Z, et al. (2010) A proposed model of online consumer behavior: Assessing the role of gender. *Journal of Business Research* 63(9): 926–934.
- Ringle CM, Wende S and Will S (2005) SmartPLS 2.0 (M3) beta. Available at: <http://www.smartpls.de/> (accessed 5 November 2012).
- Rogers EM (2003) *Diffusion of Innovations*. New York: Free Press.
- Ryan RM and Deci EL (2000a) Intrinsic and extrinsic motivations: Classic definitions and new directions. *Contemporary Educational Psychology* 25(1): 54–67.
- Ryan RM and Deci EL (2000b) Self-determination theory and the facilitation of intrinsic motivation, social development, and well-being. *American Psychologist* 55(1): 68–78.

- Ryan RM, Rigby SC and Brzybylski A (2006) The motivational pull of video games: A self-determination theory approach. *Motivation and Emotion* 30(4): 344–360.
- Schwarz A, Schwarz C, Jung Y, et al. (2012) Towards an understanding of assimilation in virtual worlds: the 3C approach. *European Journal of Information Systems* 21(3): 303–320.
- Shin DH (2009) The evaluation of user experience of the virtual world in relation to extrinsic and intrinsic motivation. *International Journal of Human-Computer Interaction* 25(6): 530–553.
- Sivunen A and Hakonen M (2011) Review of virtual environment studies on social and group phenomena. *Small Group Research* 42(4): 405–457.
- Sledgianowski D and Kulviwat S (2009) Using social network sites: The effects of playfulness, critical mass and trust in a hedonic context. *Journal of Computer Information Systems* 49(4): 74–83.
- Strader TJ, Ramaswami SN and Houle PA (2007) Perceived network externalities and communication technology acceptance. *European Journal of Information Systems* 16(1): 54–65.
- Stutzman TM and Green SB (1982) Factors affecting energy consumption: Two field tests of the Fishbein-Ajzen model. *Journal of Social Psychology* 117(2): 183–201.
- Taylor S and Todd P (1995a) Decomposition and crossover effects in the theory of planned behavior: A study of consumer adoption intentions. *International Journal of Research in Marketing* 12(2): 137–155.
- Taylor S and Todd PA (1995b) Understanding information technology usage: A test of competing models. *Information Systems Research* 6(2): 144–176.
- Teng C (2010) Customization, immersion satisfaction, and online gamer loyalty. *Computers in Human Behavior* 26(6): 1547–1554.
- Teng C, Chen M, Chen Y, et al. (2012) Loyalty due to others: The relationships among challenge, interdependence, and online gamer loyalty. *Journal of Computer-Mediated Communication* 17(4): 489–500.
- Valente TW (1995) *Network Models of the Diffusion of Innovations*. Cresskill, NJ: Hampton Press.
- Van der Heijden H (2003) Factors influencing the usage of websites: The case of a generic portal in The Netherlands. *Information & Management* (6): 541–549.
- Van Slyke C, Ilie V, Lou H, et al. (2007) Perceived critical mass and the adoption of a communication technology. *European Journal of Information Systems* 16(3): 270–283.
- Vasalou A, Joinson A, Bänziger T, et al. (2008) Avatars in social media: Balancing accuracy, playfulness and embodied messages. *International Journal of Human-Computer Studies* 66(11): 801–811.
- Venkatesh V (2003) User acceptance of information technology: Toward a unified view. *MIS Quarterly* 27(3): 425–478.
- Venkatesh V and Brown SA (2001) A longitudinal investigation of personal computers in homes: Adoption determinants and emerging challenges. *MIS Quarterly* 25(1): 71–102.
- Verhagen T, Feldberg F, Van den Hooff B, et al. (2011) Satisfaction with virtual worlds: An integrated model of experiential value. *Information & Management* 48(6): 201–207.
- Verhagen T, Feldberg F, Van den Hooff B, et al. (2012) Understanding users' motivations to engage in virtual worlds: A multipurpose model and empirical testing. *Computers in Human Behavior* 484–495.
- Yang H, Wu C and Wang K (2009) An empirical analysis of online game service satisfaction and loyalty. *Expert Systems with Applications* 36(2): 1816–1825.

Jani Merikivi is currently a PhD student at the University of Turku. His research interests are information system use behavior, virtual worlds and online youth work. His research has been published in international journals such as *Information & Management* and *Computers in Human Behavior*.

Tibert Verhagen is an associate professor in e-business at the Faculty of Economics and Business Administration of the VU University Amsterdam. His research interests include online consumer behavior, emerging technologies, online retailing, and measurement validation. His research has been published in journals such as *Information & Management* (three times), the *European Journal of Information Systems* (two times), the *Journal of Computer-Mediated Communication*, and *Computers in Human Behavior*.

Frans Feldberg is an associate professor at the Knowledge, Information and Networks research group, Faculty of Economics and Business Administration, VU University Amsterdam. His research interests include online decision-making, decision support systems, business analytics, and team collaboration in virtual environments. His research has been published in journals such as *Information & Management* and *Computers in Human Behavior*.

Appendix I

Appendix scales and measure items

Constructs	Items (1=Strongly disagree; 7=Strongly agree)	Source
Perceived usefulness	Allows me to express myself Comes in handy for my communication Is a good way to spend free time	Davis (1989); Davis et al. (1989)
Enjoyment	It is enjoyable to use Habbo It is fun to use Habbo It is entertaining to use Habbo	Hsieh et al. (2008); Venkatesh and Brown (2001)
Social influence	My family thinks I should use Habbo My relatives think I should use Habbo My friends think I should use Habbo	Ajzen (2005); Karahanna et al. (1999)
Perceived critical mass	How many people about your age use Habbo? How many of your friends use Habbo? How many of the people most meaningful to you use Habbo?	Lou et al. (2000); Sledgianowski and Kulviwat (2009); Valente (1995); Van Slyke et al. (2007)
Perceived ease of use	I find Habbo easy to use I find it easy to do what I intend to do in Habbo Using Habbo does not require a lot of my mental effort Using Habbo to communicate with others is clear and understandable	Davis (1989); Davis et al. (1989); Hsieh et al. (2008)

Appendix I (Continued)

Constructs	Items (1=Strongly disagree; 7=Strongly agree)	Source
Self-efficacy	I feel comfortable using Habbo on my own I can easily operate in Habbo on my own	Agarwal et al. (2000); Compeau and Higgins (1995)
Continual intention	I feel comfortable using Habbo even if there is no one around me to tell how to use it I intend to continue using Habbo during the next three months I intend to revisit Habbo shortly I predict I will revisit Habbo in the short term	Ajzen (1991); Ajzen and Madden (1986)



Turun kauppakorkeakoulu
Turku School of Economics

ISBN 978-952-249-311-8