



Identifying core beliefs of an intercultural educator: How polyculturalism and group malleability beliefs shape teachers' pedagogical thinking and practice

Inkeri Rissanen¹ · Elina Kuusisto¹ · Jake McMullen²

Received: 10 October 2022 / Accepted: 5 April 2023
© The Author(s) 2023

Abstract

Manifestations of educational inequity in diversifying societies have led to a wide acknowledgement of the need to develop all teachers' competencies to work in the context of diversity. The domain of beliefs and attitudes is generally included as one key component of teachers' intercultural competence, but there is little consensus over what the core beliefs shaping teachers' intercultural competencies are. This mixed methods study draws from social psychological research on inter-group relations and explores the role of polyculturalist beliefs and group malleability beliefs in shaping teachers' orientation to teaching for diversity and social justice. A hypothesized model was tested on survey data from Finnish comprehensive school teachers ($N=231$) with structural equation modeling. Findings indicate that polyculturalism, in particular, strongly explains teachers' teaching for social justice beliefs and enthusiasm for teaching in the context of diversity. Furthermore, we present a case analysis, based on classroom observations and stimulated recall interviews, of how polyculturalism actualizes in one Finnish elementary school teacher's pedagogical thinking and practice, and discuss the implications of our findings for teacher education and further research.

Keywords Intercultural competence · Teachers · Polyculturalism · Malleability beliefs · Teaching for social justice

✉ Inkeri Rissanen
inkeri.rissanen@tuni.fi

¹ Faculty of Education and Culture, Tampere University, P.O.Box 700, FI-33014 Tampere, Finland

² Department of Teacher Education, Educarium, University of Turku, Assistentinkatu 5, 20014 Turku, Finland

1 Introduction

The existing achievement gaps and other manifestations of educational inequity in diversifying societies have led to a wide acknowledgement of the need to develop all teachers' competencies to work in the context of diversity. Despite the multiplicity of models and conceptual approaches of intercultural competencies, the general definition of it as the "ability to effectively and appropriately interact in an intercultural situation or context" (Perry & Southwell, 2011, p. 453) is still widely used. When applied to teachers, this means the ability to teach effectively and in an ethically responsible manner in an intercultural context. The domain of beliefs and attitudes is generally included as one key component of teachers' intercultural competence: however, there is little consensus over what the core beliefs and attitudes are or how they should be articulated and developed in teacher education (Deardoff, 2006; Fantini, 2009; Gay, 2010; Leh et al., 2015). Often the efforts to influence teachers' attitudes concerning diversity are reported to have very limited success (see e.g., Arsal, 2019).

There are many known mechanisms through which teachers' beliefs affect students' learning and the development of social relations in the classroom and in the school. Teachers' expectations, which often are biased to some degree and based on beliefs about students' linguistic, ethnic and socio-economic background being associated with their academic potential, can become self-fulfilling prophecies and affect student achievement (Jussim & Harber, 2005). Despite the fact that teachers' pedagogical practices are known to be largely shaped by their implicit and explicit beliefs (Gay, 2010), the relationship between beliefs and practice has proved to be more complex than thought, and studies have also demonstrated challenges in effectively influencing beliefs in teacher education (Skott, 2014). Often teachers' work in managing the complex social dynamics and rapidly changing situations in the school is reactionary and steered by implicit beliefs rather than well-informed and internalized professional principles (Thornberg, 2008). Scholars call for the empirical identification of beliefs that are truly relevant for the moral work of teaching (Sanger & Osguthorpe, 2011)—for instance, for the promotion equity and social justice through education (Gay, 2010).

During the past decade or two, approaches of intercultural education have been heavily criticized for relying on essentialism (a belief that groups of people or cultures have an underlying essence) and culturalism (an approach emphasizing the significance of cultures as organic wholes and their power to determine the behavior of individuals and groups) (e.g., Dervin, 2015, 2020; Holliday, 2010). The emergence of critical approaches mirrors a "critical turn" in intercultural communication studies and a reconceptualization of culture to include critical perspectives focusing on issues of power as well as historical, contextual and structural factors (Halualani et al., 2009). Altogether, the widely advocated starting point of contemporary intercultural education is a departure from culturalism and essentialism, emphasis on cultures as fluid, interconnected and changing, and focus on the promotion of equity and social justice (e.g. Dervin, 2020; Gorski,

2016). However, empirical research on teachers' beliefs about cultures and cultural diversity, and how these manifest in their pedagogical thinking and practice, is scarce. Quantitative approaches using validated measures to map teachers' cultural diversity beliefs, in particular, are needed.

This study draws from social psychological research on inter-group relations and applies measures developed in that field to the study of teachers' intercultural professionalism. Two notions—*polyculturalism*, which is a diversity belief emphasizing the interconnectedness and malleability of cultures, (e.g., Morris et al., 2015), and *group malleability beliefs*, which refer to beliefs about the ability to human groups to change (e.g., Rydell et al., 2007) are potentially particularly relevant for intercultural education. They both are beliefs which, to some extent, challenge essentialist thinking and their positive influence for intergroup interaction has been demonstrated in social psychological studies (see Carr et al., 2012; Rosenthal & Levy, 2010 for reviews). However, these concepts have rarely been utilized in educational research, and (to our knowledge) they have not been previously looked together. In this mixed methods study, we measured polyculturalist and group malleability beliefs among Finnish teachers, and analyzed their power to explain teachers' orientation to teaching for diversity and social justice. Furthermore, to achieve a deeper understanding of the actualization of these beliefs in teachers' pedagogical thinking and practices, we present an in-depth case study of one elementary school teacher.

In this study, we focus on orientation to teach for diversity and social justice as the key competence of an intercultural educator. *Orientation to teach for diversity* is understood as general willingness and motivation to teach diverse groups. We operationalize it in terms of enthusiasm for teaching in the context of diversity. When teachers feel enthusiastic about interacting with students and families from diverse backgrounds and enjoy teaching diverse groups, they are more likely to react with active engagement rather than avoidance in challenging situations (Petrović et al., 2016). In addition, teacher enthusiasm predicts the quality of teaching as well as student interest and achievement (Baumert & Kunter, 2013; Dewaele & Li, 2021; Kunter et al., 2011; Petrović et al., 2016), meaning that it is inextricably linked to teachers' ability to promote educational equity and social justice. Orientation to teaching for social justice has been defined in multiple ways—e.g., as a passion for equity and social justice (Nieto, 2005, p. 204), as activism and the development of socio-cultural consciousness in the visions of teaching and learning (McDonald & Zeichner, 2009), or as the recognition and challenging of classroom, school, and societal practices that reproduce inequity (Cochran-Smith et al., 2016). In this study, we focus on beliefs about teaching for social justice. More specifically, these are beliefs concerning the responsibility of teachers to aim at fostering social justice and equity through their work in the context of diversity (Ludlow et al., 2008).

2 Polyculturalism and group malleability beliefs

Polyculturalism is a diversity belief (also referred to as diversity ideology or inter-group ideology) which refers to belief in the interconnectedness and malleability of cultures. It is based on a network rather than a categorical view of cultural influence:

polyculturalism emphasizes the continuous exchanges and interconnections between cultural groups and understands individuals' engagement with cultures as partial and plural (Morris et al., 2015). It aligns with the multiculturalist recognition of the relevance of cultural differences, but avoids culturalism and emphasizes cultural change, whereas multiculturalism (another extensively researched diversity belief) is based on more static view of cultural difference (Rosenthal & Levy, 2010). Polyculturalism is closely related to the concept of interculturalism: they both put emphasis on interactions and openness to change. However, interculturalism is a normative concept that emphasizes the need for intercultural exchange and dialogue, and is often used as a more broad term, whereas polyculturalism refers to beliefs about the connections between and changeability of cultures, which form a lay theory influencing interpretations and behavior in intercultural situations (Tjipto & Bernardo, 2019; Yogeewaran et al., 2020).

Awareness of the intersectionality of differences has led some scholars of critical intercultural education to propose an avoidance of the notion of culture and a terminological shift from culture to “culturality” or “diversity” (Abdallah-Preteuille, 2006; Dervin, 2015; Gorski, 2016). Polyculturalism relies on the concept of culture—but in comparison to multiculturalism, places more emphasis on the interconnectedness and malleability of cultures. Culture continues to be a relevant concept indispensable to understanding human behavior, but it should be used without attributing cultural traits to nations or static cultures (O’Sullivan, 2013). Both polyculturalism and multiculturalism contrast with color-blindness, which is a diversity belief that sees cultural difference irrelevant and leads to the strategy of tackling prejudices and discrimination by de-emphasizing group categories and paying attention to similarity or individuality only (Morris et al., 2015; Rosenthal & Levy, 2010). While color-blindness has been shown to diminish ingroup bias and stereotyping in some situations (Wolsko et al., 2000, 2006), it also hampers the recognition of bias and discrimination, naturalizes dominant identities and their privileges, and is more commonly advocated by members of the majority (Apfelbaum et al., 2010; Bonilla-Silva, 2015; Ryan et al., 2010).

Many positive intergroup effects have been associated with both multiculturalism and polyculturalism: appreciation and comfort with diversity and a willingness for intergroup contact (Rosenthal & Levy, 2012), positive attitudes toward people from other countries and cultural groups (Bernardo et al., 2013; Rosenthal et al., 2015), and cultural intelligence (Bernardo & Presbitero, 2017). Polyculturalism and multiculturalism are known to correlate positively with each other and negatively with explicit discrimination; however, factor analyses have established them as distinct constructs (Bernardo et al., 2016; Pedersen et al., 2015; Rosenthal & Levy, 2010). In comparison to color-blindness and assimilation (a diversity belief emphasizing the need for minorities to adapt to the majority culture), multiculturalism predicts smaller belonging and achievement gaps in schools (Celeste et al., 2019); however, the most critical aspect of multiculturalism is that it can lead to more stereotyping and greater perceived differences between groups (Ryan et al., 2010; Wolsko et al., 2000, 2006). Evidence is beginning to emerge that when multiculturalist recognition of diversity is paired with polyculturalist belief in the malleability and interconnectedness of cultures, many

of the problems linked to multiculturalism are avoided. For instance, a study by Osborn et al. (2020) found an association between multiculturalism and perceptions of threat with regard to increasing demographic diversity, but this effect was reversed by the endorsement of polyculturalist belief. Polyculturalism is also associated with a key aspect of cultural awareness—a willingness to criticize one's own tradition (Rosenthal et al., 2012). For these reasons, we chose to focus on polyculturalism in this study and hypothesize it to have a role in explaining teachers' orientation to teaching for diversity and social justice.

Research on polyculturalism in educational settings is yet scarce. Higher education students who begin their studies in a culturally diverse educational institution and hold polyculturalist beliefs have been found to show positive intercultural interaction, feelings of belonging as well as less anxiety (Rosenthal et al., 2016). A German study analyzing classroom cultural diversity climate found that cultural diversity beliefs vary not only individually but also between classrooms. Polyculturalist climate, in which intercultural connections and malleability of cultures were emphasized, seemed to lessen the experiences of discrimination that were sometimes brought about multiculturalist celebration of stereotypical diversities. Polyculturalist classroom diversity climate also predicted immigrant students' stronger commitment to school (Schachner et al., 2021).

Another set of beliefs that has been shown to benefit intergroup interaction is beliefs about the malleability of groups. People hold different beliefs concerning the extent to which individual and group traits are malleable or fixed (also called fixed or growth mindsets). These beliefs have implications for what types of information people attend to and how they make sense of the social world (Dweck, 2000). Research has shown that low belief in the malleability of humans gives rise to prejudices, stereotypes and essentialist beliefs and magnify their influence; in intergroup encounters, it predicts more aggression and anxiety, a lack of affective warmth, discriminatory treatment and less openness and willingness to work toward improvement (e.g., Carr et al., 2012; Dweck, 2012; Rattan & Georgeac, 2017). Beliefs concerning the malleability of individuals versus groups have somewhat diverging effects: low malleability beliefs concerning groups have additional causal implications for stereotyping (Rydell et al., 2007). Interventions that target group malleability beliefs by demonstrating the malleability of cultural groups have been able to increase positive emotions and enhance cooperation in intergroup encounters (Goldenberg et al., 2017). Beliefs about the capability of change in groups are also related to political identity and ideas of social justice: endorsement of entity beliefs about groups (not seeing groups as malleable) means believing that disadvantaged groups are incapable of change, and seeing their social positioning as justified (Rissanen & Kuusisto, 2023; Kahn et al., 2018).

While it is often assumed that directly addressing prejudices and stereotypes serves to improve intercultural encounters, without changing the implicit core beliefs that sustain stereotypical or prejudiced thinking, long-lasting attitudinal changes can be difficult to achieve. As described above, polyculturalist beliefs and group malleability beliefs have both been found to promote good-quality intergroup interaction and relations. We will use measures previously validated in several country contexts

to study these constructs among Finnish teachers. Our research questions are formulated as follows:

- (1) How do Finnish comprehensive schoolteachers self-rate their polyculturalist and group malleability beliefs, as well as their orientation to teaching for diversity and social justice?
- (2) How are Finnish teachers' polyculturalist and group malleability beliefs associated with their orientations to teaching for diversity and social justice?
Hypothesis: Polyculturalism and group malleability beliefs positively relate to social justice beliefs and enthusiasm for teaching in the context of diversity.
- (3) How do these beliefs manifest in teacher's pedagogical thinking and practice?

3 The Finnish context

Finland's success in the Program for International Student Assessment (PISA) was notable at the beginning of the twenty-first century, and the high quality of Finnish teacher education and high professional competence of teachers has often been speculated as a reason for this. Finnish comprehensive school teachers (class teachers in grade levels 1–6 and subject teachers in grades 7–9) are highly educated, with a master's degree in education or in their subject, respectively, and with university-level teacher education. They are highly valued, trusted and autonomous professionals (Tirri, 2014). Despite its reputation for excellence, Finnish teacher education has traditionally "been very ethnocentric and based on monocultural views of Finns and Finnish culture" (Räsänen, 2009, p. 46). Furthermore, according to the PISA results, the underachievement of second-generation immigrants (not driven by socio-economic status) is particularly severe in Finland (Borgna & Contini, 2014).

There seems to be a remarkable gap between the official principles and practical reality of intercultural education in the Finnish education system. As in other Nordic countries, equality and inclusiveness are central values in Finnish educational policy (Arnesen et al., 2007). The Finnish national curriculum for basic education, in particular, is markedly multi/interculturalist in its orientation, and it demands that all students' cultural and religious identities be recognized and supported. It employs a strong non-essentialist discourse of cultural identities by articulating diversity as a feature of all students, and Finnish cultural heritage as being constantly shaped by different cultures in history as well as in the present (Zilliacus et al., 2017). However, research on Finnish teachers as well as the educational experiences of minorities paints a different picture. Despite the relative commonality of the (superficial) acknowledgement of the value of diversity and need for culturally responsive teaching practices, educators' beliefs and attitudes continue to reflect monolingual and monocultural ideologies as well as negative attitudes toward significant minority groups, such as Muslims (Alisaari et al., 2019; Kimanen et al., 2019; Rissanen, 2021; Rissanen et al., 2015).

Thus, Finnish schools and teachers have contributed to maintaining the illusion of a homogeneous Finnish national identity. Even though large scale immigration to Finland started later than in many European societies, much diversity already

has existed in Finnish society before that: two official languages, several historical minorities, and an indigenous population (the Sami) (Holm & Londen, 2010). At the moment, approximately 7% of the population are foreign-language residents (Official Statistics of Finland, 2018). Structural efforts of affirming diversity in the educational system include the provision of mother tongue instruction as well as religious education “according to the student’s own religion.”

4 Data and methods

4.1 Participants

Finnish in-service teachers ($N=231$) responded to a self-report questionnaire. The study relied on purposive non-probability sampling with the purpose of including the demographic heterogeneity of the respondents’ areas and schools. As a voluntary recruitment strategy with a low response-rate in this type of study

Table 1 Participants’ background information

Background variables	$N=231$
Age	$M=45.52$ ($SD=9.72$) min 25, max 63
<i>Gender</i>	
Female	173 (75%)
Male	58 (25%)
Other	–
Teaching experience in years	$M=16.36$ ($SD=10.17$) min 0, max 37
<i>Working as</i>	
Class teacher (grades 1–6)	61 (26%)
Subject teacher (grades 7–9)	111 (48%)
Other	49 (21%)
Having experience of cultural diversity (scale 1–5)	$M=3.56$ ($SD=1.05$)
<i>Number of pupils in school</i>	
1–49	5 (2%)
50–299	25 (11%)
300–499	73 (32%)
500–999	100 (43%)
Over 1000	28 (12%)
<i>Percentage of Finnish as a second language students in school</i>	
Below 5%	57 (24%)
5–20%	74 (32%)
21–40%	48 (21%)
Over 40%	52 (23%)

would have increased the likelihood of having a sample biased toward teachers that are more interested in interculturality, collaboration with schools and teacher education courses was regarded as a better strategy. Seven schools from six municipalities across the country participated. The response rate (of all teachers who received the online link) was 60%.

The majority of participants were females (Table 1). Their age ranged from 25 to 63 years ($M=45.52$ years, $SD=9.72$) and they had from 0 to 37 years of teaching experience ($M=16.36$ years, $SD=10.17$). In this sample, 26% were class teachers, 48% subject teachers and 21% others (e.g., special education teachers). Teachers were asked to evaluate how much experience they had of cultural diversity ($M=3.56$ on a 1–5 scale). The linguistic and cultural diversity of the teachers' schools was also indicated by asking the teachers to report the percentage of Finnish as a second language (FSL) students in their schools. The national average of FSL students is 6.8%, which means teachers with experience of working in culturally and linguistically diverse schools were (purposefully) overrepresented in our sample (see Table 1).

4.2 Procedure

The study was part of a larger mixed-methods project called Implicit Beliefs of Malleability as the Core of Teachers' Intercultural Competence (CORE), which explored the connections between malleability beliefs and intercultural competence in Finnish teachers' pedagogical thinking and practices. An online self-report questionnaire was developed, and the data collection was carried out in 2019 and 2020. Comprehensive schools were recruited to participate in the research by contacting the principals. In the schools that participated, the principals organized an opportunity for teachers to respond during their working hours either in the presence of a researcher or independently. The link to the online survey was distributed to teachers in these organized sessions. In return, the schools had an opportunity to request an (online) lecture for teachers from the research team.

4.3 Measures

Group malleability beliefs were measured using the 4 reversed items from the *Implicit theory of the malleability of groups* (ITG) instrument that was first developed by Rydell et al. (2007) by re-wording the original Levy and Dweck scale about implicit theories of individuals to study implicit theories about groups, and then further developed by Halperin et al. (2011) (e.g., "Groups can do things differently, but the important parts of who they are can't really be changed"). A 6-point Likert scale was used, ranging from 1 = strongly disagree to 6 = strongly agree.

Polyculturalism (POLY) was measured using the five polyculturalism items from Rosenthal and Levy's (2012) lay theories of culture scale (e.g., "Different cultural groups impact one another, even if members of those groups are not completely aware of the impact") with a 5-point Likert scale (1 = strongly disagree to 5 = strongly agree).

The teachers' orientation to teaching for diversity and social justice was measured using two instruments. We used a six-item version (items 1, 2, 3, 4, 7, 8) of *Learning to Teach for Social Justice-Beliefs Scale* (SJB) (Ludlow et al., 2008), that focus on beliefs concerning the responsibility of teachers to aim at developing social justice and equity in the context of diversity (e.g., "Part of the responsibilities of the teacher is to challenge school arrangements that maintain societal inequities", and "an important part of learning to be a teacher is examining one's own attitudes and beliefs about race, class, gender, disabilities, and sexual orientation"). This six-item version has been validated among Finnish teachers (Rissanen & Kuusisto, 2022).

We measured enthusiasm for teaching in the context of diversity using the *Teacher Cultural Diversity Enthusiasm Scale* that has six items (e.g., "I would like to teach students from different cultural backgrounds") (ENT) (Petrović et al., 2016). Both ENT and SJB instruments used a 5-point Likert scale ranging from 1 = strongly disagree to 5 = strongly agree.

All the scales were double-blind translated into Finnish.

4.4 Analysis

IBM SPSS Statistics 25 was utilized for descriptive statistics. Structural equation modeling (SEM) was conducted with the Mplus 8.0 program (Muthèn & Muthèn, 1998–2017). Since the variables were not normally distributed, we utilized robust maximum likelihood estimation (MLR) as the analysis method (Byrne, 2012). The criteria utilized for a good model fit were comparative fit index (CFI) > 0.95, the Tucker–Lewis index (TLI) > 0.95, root-mean-square error of approximation (RMSEA) < 0.06 and standardized root mean square residual (SRMR) < 0.05 (Byrne, 2012). Hypothesis 1 was tested by studying the direct effects of ITG and POLY on ENT and SJB.

4.5 Qualitative case study

We present also an in-depth qualitative case study of a one elementary school teacher, Laura (pseudonym). Based on SEM results, a decision was made to focus on polyculturalism in the qualitative analysis. She was recruited among the survey respondents due to her answers to both quantitative and qualitative survey questions indicating high polyculturalism (POLY $M=5.0$) as well as a strong orientation to teaching for diversity and social justice (SJB $M=5.0$, ENT $M=5.0$). Her group malleability beliefs were moderately high (ITG $M=3.5$). In the survey she indicated her willingness to participate in the qualitative phase of the project. The data includes Laura's answers to two open-ended survey questions (1. Everyone has their own understanding and experience of cultural diversity. What does it mean to you? 2. What do you think about the prospects for groups, e.g., cultural, ethnic or religious groups, to change and develop?), one preliminary interview, and 3 stimulated recall (STR) interviews during which critical incidents from 5 observed and video-recorded lessons, first identified by the researcher from the video recordings,

were watched with the teacher. In STR-interviews informants view past actions using video recordings to stimulate memory, which enables them to remember their past thoughts with greater validity (Tochon, 2009). Interviewees are then asked to reflect on the critical incidents and give reasons for her actions in these situations. In this study, critical incidents were moments in which the researcher saw the teacher's diversity beliefs manifesting or where questions of diversity and social justice were apparent.

Interviews (total of 210 min) were transcribed verbatim. In total, the transcribed qualitative data amounted to 36 pages/19,800 words. In order to analyze how polyculturalist diversity beliefs manifest in Laura's pedagogical thinking and practice, we used thematic analysis (Fereday & Muir-Cochrane, 2006) and formed theory-driven but inductively specified main themes of the dimensions that have been linked with polyculturalism in this and earlier quantitative studies: *polyculturalist perception of cultural diversity, openness and interest to diversity, positive intergroup attitudes and willingness for intergroup collaboration, cultural intelligence and self-criticism as well as orientation to social justice* (Bernardo et al., 2013; Bernardo & Presbitero, 2017; Pedersen et al., 2015; Rissanen et al., 2023; Rissanen & Kuusisto, 2023; Rosenthal & Levy, 2012; Rosenthal et al., 2015, 2016; Tjipto & Bernardo, 2019). The contents of these themes were specified by simultaneous reading of earlier research and the case study data (see Table 2). After that, meaning units expressing manifestations of these dimensions of polyculturalism in Laura's thinking and practice (typically from one to ten sentences) were identified. A total of 153 meaning units were identified and coded from the qualitative data (Table 2).

5 Results

5.1 Descriptive statistics and structural equation modelling

The reliabilities of all scales were on the acceptable and good level (Table 3). The correlation matrix in Table 4 shows that all four constructs correlated with each other positively and statistically significantly. The means show that Finnish teachers self-rated their polyculturalist ($M=4.08$, $SD=0.64$) and group malleability beliefs ($M=4.21$, $SD=0.95$) as well as their orientation to teaching for social justice ($M=4.33$, $SD=0.62$) and enthusiasm for teaching diverse students ($M=3.92$, $SD=0.90$) at moderately high levels (see Table 3 and Fig. 1 for details). Figure 1 indicates that overall ITG and ENT appear to have elicited more varied responses than POLY and SJB, which have predominantly elicited positive self-reported beliefs.

To test Hypothesis 1, ITG and POLY were treated as independent, exogenous variables (see Fig. 2), and ENT and SJB as dependent, endogenous variables. Direct effects of ITG and POLY on both ENT and SJB were estimated. The fit indices were sufficient to accept the basic model (CFI=0.97, TLI=0.96, RMSEA=0.045, SRMR=0.05). The chi-square statistic ($\chi^2(183)=255.77$, $p<.001$) was significant, which was expected since chi-square is highly sensitive to the sample size and number of variables (Byrne, 2012). All latent variables were coherent, with factor

Table 2 Manifestations of polyculturalism in a teacher's thinking and practice: thematic analysis
Dimensions of polyculturalist thinking and their manifestations in teacher's thinking and practice

	Meaning units per dimension per data source				Total <i>F</i> = 153
	Survey <i>f</i> = 4	Pre <i>f</i> = 67	STR <i>f</i> = 75		
<i>Poly</i> culturalist perception of cultural diversity (Morris et al., 2015)	4	7	10	21	
Interconnectedness and malleability of cultures					
Cultures as internally diverse and layered					
An individual participates in many cultures					
<i>Openness to and interest in diversity</i> (Osborn et al., 2020; Rosenthal & Levy, 2012; Rosenthal et al., 2015)		17	17	34	
Expressing interest in students' everyday realities and ways of thinking					
Explaining teacher's own culturally laden assumptions to students					
Promoting visibility of and open discussions around cultural diversity					
<i>Positive inter-group attitudes and willingness for intergroup collaboration</i> (Bernardo et al., 2013; Rosenthal & Levy, 2012; Rosenthal et al., 2015)		16	22	38	
Recognizing the value of different cultural resources and promoting their recognition in school and society					
Promoting active collaboration between people from different cultural backgrounds and active participation of minority groups in school					
<i>Cultural intelligence and cultural self-criticism</i> (Bernardo & Presbitero, 2017; Rosenthal et al., 2012)		15	17	32	
Cultural self-awareness: identification of multiple cultural influences					
Ability to shift between cultural perspectives					
Cultural self-criticism: challenging cultural norms in school and society					
<i>Orientation to social justice</i> (Osborn et al., 2020; Rissanen et al., 2023; Rissanen & Kuusisto, 2023; Rosenthal & Levy, 2012)		12	19	31	
Identifying problems of inequity and social justice in school and in society, seeing their mitigation as part of a teacher's job					
Raising awareness and serving as advocate of minoritized students in school					

Survey = Open-ended survey questions, Pre = Preliminary interview, STR = Stimulated recall interview

Table 3 Descriptive statistics of scales

Scale	<i>N</i>	Items	α	Min	Max	<i>M</i> (<i>SD</i>)
Implicit theory of the malleability of groups (ITG)	231	4	0.820	1.5	6	4.21 (0.95)
Implicit theory of polyculturalism (POLY)	231	5	0.885	1	5	4.08 (0.64)
Learning to teach for social justice-beliefs scale (SJB)	231	6	0.769	1	5	4.33 (0.62)
Teacher cultural diversity enthusiasm scale (ENT)	231	6	0.943	1	5	3.92 (0.90)

Table 4 SEM model construct correlation matrix (Kendall's tau)

	ITG	POLY	SJB
ITG	–		
POLY	0.213**	–	
SJB	0.144**	0.376**	–
ENT	0.131**	0.155**	0.345**

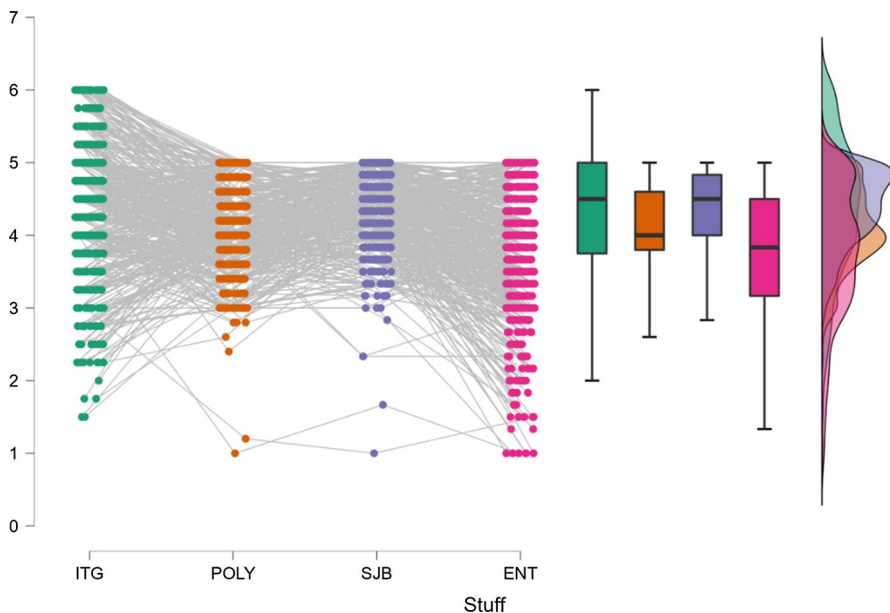
** $p < 0.01$ **Fig. 1** Raincloud, box, and violin plots of scales for all participants

loadings above 0.4 (see Appendix 1 for complete factor structures). This indicates that the latent constructs were sufficiently modeled by the observed questionnaire items.

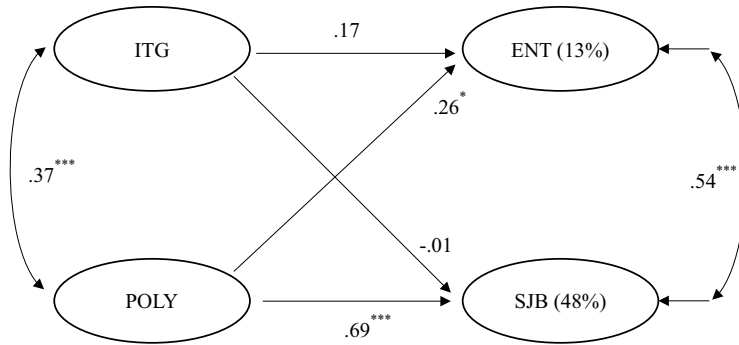

Fig. 2 Model predicting teachers’ cultural enthusiasm and teaching for social justice beliefs by implicit theories of groups, and polyculturalism. The numbers in parentheses after the variable names indicate the variance accounted for. Significance levels: * $p < .05$ *** $p < .001$

Overall, the model explained 48% of the variance in SJB and 13% in ENT, indicating that at least a good deal of teachers’ social justice beliefs can be explained by their cultural beliefs. In particular, POLY had a strong direct effect on SJB ($\beta = 0.69$, $p < .001$) and ENT ($\beta = 0.26$, $p < .05$). As well, ITG and POLY had a rather high correlation with each other. But, contrary to Hypothesis, ITG did not have a statistically significant effect on SJB ($\beta = -0.01$, $p = .914$) or ENT ($\beta = 0.17$, $p = .06$) in this model. These results suggest that only polycultural beliefs are a direct explanation for social justice and diversity enthusiasm, when both polycultural beliefs and group malleability beliefs are considered at the same time. Thus, we explore the role of polycultural beliefs in teachers’ pedagogical thinking and practice in the following case study.

5.2 Qualitative case study: polyculturalism in one Finnish teacher’s pedagogical thinking and practice

We present a case analysis of Laura (pseudonym), who works as a FSL (Finnish as a second language) and special education teacher in an elementary school. She is also a qualified class teacher and has 30 years of teaching experience. As presented above, Laura was recruited for the qualitative in-depth study from among the survey participants due to her answers indicating markedly strong polyculturalist views as well as her strong orientation to teaching for diversity and social justice. Laura works in a school in a socio-economically mixed area. She describes the school as having experienced a rather sudden increase in students with immigrant background—these students still are a rather small minority, but a more visible one than before. Next, we will demonstrate how polyculturalism manifests in Laura’s pedagogical thinking and practice.

5.2.1 Polyculturalist perception of cultural diversity

Polyculturalist perception of cultural diversity was apparent in all data collected from Laura (Table 2). Here is how she wrote about her views concerning cultural diversity in the survey:

People who belong to a certain group may have habits and perceptions that resemble each other's, but all humans are individuals and there is a lot of variation inside cultures. For me, cultural diversity means that we acknowledge there are different cultures and ways of doing things. All of us belong to many cultures simultaneously, and what is at the front depends on the things and perspectives in question. There are ethnic groups, but also we belong to groups related to high culture e.g. opera, and there are sub-cultures, political groups and so on. And through that, everyone has their own cultures so we live in the middle of a variety of cultures and an individual participates in many cultural groups. (Open-ended survey question about meanings given to cultural diversity)

These views reflect a network view of cultures as well as ideas that an individual participates in many cultures, both key aspects of polyculturalism (Morris et al., 2015). Laura's polyculturalist views about interconnectedness and malleability of cultures came forth in the interviews:

If you think about Finnish culture, for instance, people who come from different cultures shape it all the time, and maybe we try to pick the best features and embrace those. And the more a certain culture is in a minority position it gets molded... by the majority culture, or sometimes it happens that, temporarily, this leads to efforts of protecting the stability of your own culture. (Pre- interview)

Laura also communicated her polyculturalist views to students. The following presents an incident from one lesson, bringing forth classroom-level negotiations around cultural authenticity, as well as Laura's way of reacting to that and aspiring a polyculturalist representation of cultures:

Halloween is approaching and Laura discusses ways of celebrating Halloween with the students, and how Halloween is likely to show in the school this year.

Student 1: We don't do Halloween

Laura: In your class?

Student 1: No, at home

Student 2: Neither do we, we're Muslims

Laura: Yes, this is not something that everyone needs to do

Student 1: Arabs, this is not their celebration

Laura: Yes, and I will soon tell you how it has not been a Finnish celebration but it has like gradually become one

Student 1 & 2 continue the discussion by telling what kind of Halloween costumes they will be wearing at school. Later on, Laura talks about All

saint's day celebrations in Finland and how these nowadays get mixed with or replaced by Halloween celebrations.

(Lesson 4, 1. STR-interview).

In the STR interview Laura reflects on this conversation:

Researcher: You have been talking about how teaching about Finnish culture is an important part of FSL subject. Is teaching about Halloween part of that?

Laura: I think it kind of is. You could say it is not Finnish tradition but... it is a little embarrassing for these students if they are not aware of what happens. [...] Too easily we think about culture as something very traditional, or like... sublime. In the early years of my career it was really important for me to teach about all these things like.. [lists traditional Finnish clothing and artefacts], these things nobody has ever seen including me, so... I understand that they are part of teaching history, but...[...].let's concentrate on things that are here and now. (3. STR-interview)

Laura's reflections on the nature of culture were grouped in the analysis under the first theme of analysis, but her polyculturalist views also emerged as a pervasive aspect shaping all the analysis themes.

5.2.2 Openness to and interest in diversity

Under this theme were grouped expressions reflecting Laura's interest in students' and their families' everyday realities and ways of thinking, as well as her practices of explaining her own culturally laden assumptions to students and promoting open discussion around cultural diversity (Table 2). For Laura, a key pedagogical principle in teaching culturally diverse classes is to acquire as much knowledge of students' every-day realities as possible, in order to learn to recognize where different cultural assumptions influence students' ways of relating to what happens in school. She also regards it important to openly explain her own culturally laden viewpoints to students when deemed relevant, and thinks it is important for a teacher to be able to adapt to diversity and encourage flexibility around the school norms:

I can't change who I am or how this school works, but I can be as flexible as possible, and try to articulate it for the students, like, I have a feeling that you might expect me to act like this in this situation but that is not how I will act [...] or, like, can you tell me what you do in this kind of situations when you are at home. (Pre-interview)

Multiculturalist openness towards and celebration of diversity can increase stereotypes and perceived difference between groups (Leslie et al., 2020). In Laura's thinking, multiculturalist strategies were balanced with polyculturalist ideals of being sensitive to the different ways in which individuals relate to their cultures. How to positively recognize diversity without strengthening stereotypes was a recurrent theme in her interviews:

This is difficult sometimes. If we ask a child, for instance, to tell how things are done in their countries of origin we easily strengthen this us and them-thinking... you need to remember this is not a homogeneous group [...] the children are very different, I've had some that, for instance, really want to give a presentation about Islam in religious education lesson, they've prepared power point slides and others have been able to ask questions, but then there are those who don't want anybody to mention them being Muslims, so you need to give some space... you can hint that it is possible to do these things but there's no pressure at all. (2. STR-interview)

5.2.3 Positive inter-group attitudes and willingness for intergroup collaboration

This third theme of analysis includes Laura's thoughts about the value of different cultural resources and promoting their recognition in school and society, as well as her practices of promoting active collaboration between people from different cultural backgrounds and, in particular, active participation of minority groups in school (Table 2). Laura enjoys working with immigrant students and their families. She reflected on the changes in her own attitudes that had resulted from her personal intercultural relationships and from gaining a deeper understanding of how different communities or societies function. Consequently, she advocated more active home-school collaboration with immigrant families:

One thing is that we need to develop closer collaboration so that our eyes would open. I don't mean only like THEY should understand how we do things here, but like..mutually, to have more open collaboration that would give perspective and insights into how and why you act like you do. [...] One thing that I have dreamed of but have not had enough time to realise yet, is that we could have clubs led by immigrant parents. Like a football club, why couldn't it be led in Arabic by a father of our Arabic speaking students, I'm sure Finnish speaking kids could very well play there as well [...] so that we don't meet only when there have been quarrels between the kids. (Pre-interview)

Her ideals of promoting appreciation and understanding were associated with polyculturalist perceptions about cultures as layered and complex, and the aim of learning not only *about* but *from* cultures:

Genuine understanding and appreciation of cultural diversity [should be supported], [...] not to present any cultures as more authentic or better than others – classical music and going to symphony concerts is not better and more valuable than punk. [...] so that we really would try to understand, NOT just like let's make a poster about Islam and then there always are the same simplified facts that are more likely to strengthen our ideas and thoughts like... aren't they a little silly. (Pre-interview)

Laura also endeavored to make visible the value of different languages in the school and help the multilingual children to understand the value of their language skills.

5.2.4 Cultural intelligence and cultural self-criticism

Laura's level of self-reflection was really high. Expressions of cultural self-awareness, including identification of multiple cultural influences to Laura's own thinking as well as her ability to alternate between different cultural perspectives, and manifestations of cultural self-criticism, including a tendency to challenge some hegemonic cultural norms in school and society, were grouped under the fifth theme of analysis (Table 2). Laura was able to give concrete examples of cultural learning in her own life, through which she had developed an understanding of how her own ways of thinking are culturally laden. This learning had influenced her way of working in culturally diverse school.

Sometimes I feel we are so in deep in our every-day realities that we don't get that the realities of other people can be so different that they just don't get what I'm explaining. And we might blame the language-skills. [...] Previously my thinking was much more black and white, like, this is how we do things here and that's what we're gonna do. And I saw it as a bad behavior or disobedience when someone did things differently. (Pre-interview)

In a way, Laura referred to cultural groups and traditions as entities that profoundly influence individuals' thinking. However, this way of speaking about cultures was balanced with a polyculturalist emphasis on the constant change in and interaction between the traditions, and a belief in the possibility to intentionally work towards transforming cultural norms.

5.2.5 Orientation to social justice

A strong social justice orientation was also evident in Laura's pedagogical thinking and practice. This sixth theme includes Laura's ways of identifying problems of inequity and social justice, as well as her indicating that she viewed it as a part of a teacher's job to mitigate these problems and raise awareness in school and society (Table 2). In her school, Laura feels that students with immigrant background are often experienced as a burden and problem, who require extra resources that the teachers don't have. Laura endeavors to serve as an advocate of the immigrant students in the school:

One of my biggest challenges as a teacher is to help other teachers to see that these children need to be taken into account. It can't be like, "I didn't want them here". I do understand that they don't have resources for everything, but, on the other hand, the more you pay attention to these things the easier your job will be, and taking into account cultural diversity is something that benefits all children. (Pre-interview).

Laura raised many issues related to unequal positioning of immigrant or other minority groups in Finnish society. She thought that civil influencing is, in some respect, a part of teachers' responsibilities, and talked about the importance of promoting equity and social justice through structural level solutions—for instance, by diversifying the school staff. However, she also saw much of what teachers can do to promote educational equity in their daily work—for instance, by supporting the newcomers and not lowering expectations towards them:

I've said (to other teachers) that please wait—when they learn the language, sufficiently, many of these problems will go away—there is nothing wrong with this kid [...]. Please help them, teach them the words that will help them to join in the games with other kids, for instance. (3. STR interview)

Laura's orientation to social justice seemed to be associated with her polyculturalist view of the naturalness of mixing cultures and languages and with the idea that social exclusion and underachievement among cultural and linguistic minorities are not inevitable but can be mitigated.

6 Discussion

Teachers' attitudes and beliefs concerning cultural diversity and social justice are typically regarded as key aspects of their competence to teach in the context of diversity, but often their conceptualization is rather vague or they are understood in terms of attitudes toward marginalized students (Gay, 2010). The purpose of this study was to explore a particular set of beliefs—polyculturalist beliefs as well as group malleability beliefs—as possible key constituents of intercultural professionalism among Finnish teachers. These beliefs, which both challenge essentialism and culturalism but with slightly different emphasis, are identified as important in the social-psychological research on intergroup relations, but have not gained much attention in the field of intercultural education (Rydell, 2007; Rosenthal & Levy, 2010; Rosenthal et al., 2016). Previous studies have shown that group malleability beliefs decrease the tendency to judge and stereotype and increase positive attitudes toward others (Goldenberg et al., 2017; Halperin et al., 2012; Levontin et al., 2013; Rydell et al., 2007). They also shape teachers' orientations to diversity and social justice (Rissanen & Kuusisto, 2023). However, the results of this study show that polyculturalist beliefs about the interconnectedness of cultures are even more influential for teachers' orientations. According to our results, in the sample of Finnish teachers, both group malleability beliefs and polyculturalist beliefs are related to teaching for diversity and social justice. However, the effect of polyculturalism is distinctly stronger when both are considered at the same time. Our results highlight the particularly important role of polyculturalist beliefs about the interconnectedness of and influences between cultures in explaining teachers' orientation to teaching for diversity and social justice. The tested model succeeded in explaining social justice orientation better

than it explained enthusiasm to teach in the context of diversity. Our case study with one Finnish elementary school teacher with high polycultural beliefs demonstrates how polyculturalism manifests in her pedagogical thinking as openness and interest to diversity, positive inter-group attitudes and willingness for collaboration, cultural intelligence and self-criticism, as well as an orientation to social justice.

Altogether, our results support the fundamental theoretical idea that seeing human groups and cultures as not static and determined but interconnected and changeable through interaction is a prerequisite for the development of the motivation to promote equity and social justice. It indicates an understanding of inequalities not as natural reflections of the difference between people, but as due to historical and contextual processes (Kahn et al., 2018; Morris et al., 2015). These views may gain their influence through strengthening teachers' beliefs in both the majoritarian groups' ability to develop a willingness for more equitable practices, as well as in the minoritized groups' opportunities to flourish when structural-level obstacles and discrimination are tackled. They may indicate an aspect of hope and a seed of empowerment for teachers—the belief in the possibility of contributing to such a cultural change in the present context that enables the development of social justice. Our findings have significant implications for developing teacher education: a focus on shaping teachers' core diversity beliefs should be the starting point for preparing competencies to teach for diversity and social justice. Pushing teachers toward intercultural education without influencing their implicit belief systems is likely to lead to superficial acquisition of principles and practices—as seems to be the case with many Finnish educators, who claim their enthusiasm to promote inclusion and affirmation of diversity, but continue to have low beliefs concerning the possibility of minorities to flourish (Rissanen et al., 2015; see also discussion in the section “The Finnish context”). A focus on the (often implicit) core beliefs in teacher education also escapes a moralizing or judgmental atmosphere that has the risk of disheartening or demotivating teachers. What beliefs people hold is not a moral question, even though the behavior these beliefs motivate might have moral consequences. Polyculturalist diversity beliefs can be strengthened by knowledge-based teaching concerning the interconnections and influences between cultures in history as well as in the contemporary world. Group malleability beliefs have been successfully influenced in interventions focused on teaching about history of cultural exchange (Goldenberg et al., 2017), with beneficial consequences for intergroup relations. Developing and researching teacher education interventions targeting polyculturalist and group malleability beliefs could be an important new opening. There are limits to what can be concluded on the basis of this study. The sample does not allow the generalization of the results to Finnish teachers. Nor can the data clarify specific causal relations between beliefs and teaching practices or orientations, especially taking into account the cross-sectional nature of the data. Intervention and longitudinal designs that examine the development of teachers' pedagogical approaches in light of their beliefs may clarify the developmental relations between these constructs. Furthermore, the study is based on self-reported data, and the constructs that are researched

are the kind that may evoke responses influenced by the effect of social desirability. However, we tried to regulate this effect by using reversed items; furthermore, we make interpretations on the relations between our constructs rather than on their levels in the sample, and there are no particular reasons to suspect that the social desirability effect would strengthen the correlations in the data. Nevertheless, we acknowledge that more research with multiple methods—and preferably iterative research alternating with qualitative and quantitative approaches—is needed in order to achieve a more solid understanding of the implications polyculturalist and group malleability beliefs for intercultural education. We consider the present research as a start for this kind of process.

Appendix 1

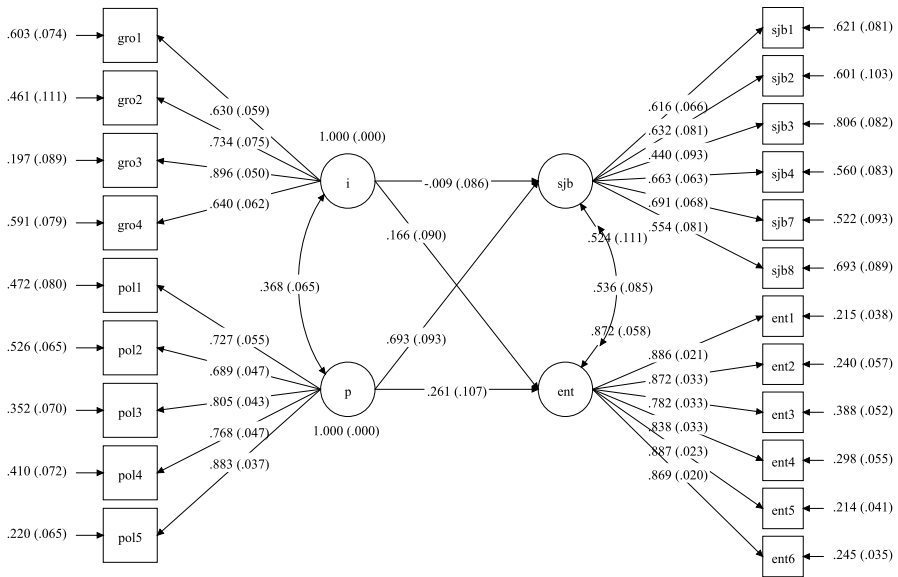

Acknowledgements This work was supported by the Academy of Finland, Grant Number 323176.

Funding Open access funding provided by Tampere University including Tampere University Hospital, Tampere University of Applied Sciences (TUNI).

Declarations

Conflict of interest There are no competing financial or non-financial interests related to this work.

Open Access This article is licensed under a Creative Commons Attribution 4.0 International License, which permits use, sharing, adaptation, distribution and reproduction in any medium or format, as long as you give appropriate credit to the original author(s) and the source, provide a link to the Creative

Commons licence, and indicate if changes were made. The images or other third party material in this article are included in the article's Creative Commons licence, unless indicated otherwise in a credit line to the material. If material is not included in the article's Creative Commons licence and your intended use is not permitted by statutory regulation or exceeds the permitted use, you will need to obtain permission directly from the copyright holder. To view a copy of this licence, visit <http://creativecommons.org/licenses/by/4.0/>.

References

- Abdallah-Preteille, M. (2006). Interculturalism as a paradigm for thinking about diversity. *Intercultural Education*, 17(5), 475–483. <https://doi.org/10.1080/14675980601065764>
- Alisaari, J., Heikkola, L. M., Commins, N., & Acquah, E. O. (2019). Monolingual ideologies confronting multilingual realities. Finnish teachers' beliefs about linguistic diversity. *Teaching and Teacher Education*, 80, 48–58. <https://doi.org/10.1016/j.tate.2019.01.003>
- Apfelbaum, E. P., Pauker, K., Sommers, S. R., & Amdady, N. (2010). In blind pursuit of racial equality? *Psychological Science*, 21(11), 1587–1592. <https://doi.org/10.1177/0956797610384741>
- Arnesen, A.-L., Mietola, R., & Lahelma, E. (2007). Language of inclusion and diversity: Policy discourses and social practices in Finnish and Norwegian schools. *International Journal of Inclusive Education*, 11(1), 97–110. <https://doi.org/10.1080/13603110600601034>
- Arsal, Z. (2019). Critical multicultural education and preservice teachers' multicultural attitudes. *Journal for Multicultural Education*, 13(1), 106–118. <https://doi.org/10.1108/JME-10-2017-0059>
- Baumert, J., & Kunter, M. (2013). The COACTIV model of teachers' professional competence. In M. Kunter, J. Baumert, W. Blum, U. Klusmann, S. Krauss, & M. Neubrand (Eds.), *Cognitive activation in the mathematics classroom and professional competence of teachers: Results from the COACTIV project* (pp. 25–48). Springer.
- Bernardo, A. B. I., & Presbitero, A. (2017). Belief in polyculturalism and cultural intelligence: Individual-and country-level differences. *Personality and Individual Differences*, 119, 307–310. <https://doi.org/10.1016/j.paid.2017.08.006>
- Bernardo, A. B. I., Rosenthal, L., & Levy, S. R. (2013). Polyculturalism and attitudes towards people from other countries. *International Journal of Intercultural Relations*, 37(3), 335–344. <https://doi.org/10.1016/j.ijintrel.2012.12.005>
- Bernardo, A. B. I., Salanga, M. G. C., Tjipto, S., Hutapea, B., Yeung, S. S., & Khan, A. (2016). Contrasting lay theories of polyculturalism and multiculturalism: Associations with essentialist beliefs of race in six Asian cultural groups. *Cross-Cultural Research*, 50(3), 231–250. <https://doi.org/10.1177/1069397116641895>
- Bonilla-Silva, E. (2015). More than prejudice restatement, reflections, and new directions in critical race theory. *Sociology of Race and Ethnicity*, 1(1), 73–87.
- Borgna, C., & Contini, D. (2014). Migrant achievement penalties in Western Europe: Do educational systems matter? *European Sociological Review*, 30(5), 670–683. <https://doi.org/10.1093/esr/jcu067>
- Byrne, B. M. (2012). *Structural equation modelling with Mplus. Basic concepts, applications, and programming*. Routledge.
- Carr, P. B., Rattan, A., & Dweck, C. D. (2012). Implicit theories shape intergroup relations. In P. Devine & A. Plant (Eds.), *Advances in Experimental Social Psychology* (pp. 127–165). Academic Press.
- Celeste, L., Baysu, G., Phalet, K., Meeussen, L., & Kende, J. (2019). Can school diversity policies reduce belonging and achievement gaps between minority and majority youth? Multiculturalism, color-blindness, and assimilationism assessed. *Personality and Social Psychology Bulletin*, 45(11), 1603–1618. <https://doi.org/10.1177/0146167219838577>
- Cochran-Smith, M., Ell, F., Grudnoff, L., Haigh, M., Hill, M., & Ludlow, L. (2016). Initial teacher education: What does it take to put equity at the center? *Teaching and Teacher Education*, 57, 67–78. <https://doi.org/10.1016/j.tate.2016.03.006>
- Dearoff, D. K. (2006). Identification and assessment of intercultural competence as a student outcome of internationalization. *Journal of Studies in International Education*, 10(3), 241–266. <https://doi.org/10.1177/1028315306287002>

- Dervin, F. (2015). Towards post-intercultural teacher education: Analysing 'extreme' intercultural dialogue to reconstruct interculturality. *European Journal of Teacher Education*, 38(1), 71–86. <https://doi.org/10.1080/02619768.2014.902441>
- Dervin, F. (2020). Creating and combining models of intercultural competence for teacher education/training: On the need to rethink IC frequently. In F. Dervin, R. Moloney, & A. Simpson (Eds.), *Intercultural competence in the work of teachers* (pp. 57–72). Routledge.
- Dewaele, J. M., & Li, C. (2021). Teacher enthusiasm and students' social-behavioral learning engagement: The mediating role of student enjoyment and boredom in Chinese EFL classes. *Language Teaching Research*, 25(6), 922–945. <https://doi.org/10.1177/1362168821101453>
- Dweck, C. S. (2000). *Self-Theories: Their role in motivation, personality and development*. Psychology Press.
- Dweck, C. S. (2012). Mindsets and human nature: Promoting change in the Middle East, the schoolyard, the racial divide, and willpower. *American Psychologist*, 67(8), 614–622. <https://doi.org/10.1037/a0029783>
- Fantini, A. (2009). Assessing intercultural competence: Issues and tools. In D. K. Deardorff (Ed.), *The SAGE handbook of intercultural competence* (pp. 456–476). Sage.
- Fereday, J., & Muir-Cochrane, E. (2006). Demonstrating rigor using thematic analysis: A hybrid approach of inductive and deductive coding and theme development. *International Journal of Qualitative Methods*, 5(1), 80–92. <https://doi.org/10.1177/160940690600500107>
- Gay, G. (2010). Acting on beliefs in teacher education for cultural diversity. *Journal of Teacher Education*, 61(1–2), 143–152. <https://doi.org/10.1177/0022487109347320>
- Goldenberg, A., Endevelt, K., Ran, S., Dweck, C. S., Gross, J. J., & Halperin, E. (2017). Making intergroup contact more fruitful: Enhancing cooperation between Palestinian and Jewish-Israeli adolescents by fostering beliefs about group malleability. *Social Psychological and Personality Science*, 8(1), 3–10. <https://doi.org/10.1177/1948550616672851>
- Gorski, P. (2016). Rethinking the Role of "culture" in educational equity: From cultural competence to equity literacy. *Multicultural Perspectives*, 18(4), 221–226. <https://doi.org/10.1080/15210960.2016.1228344>
- Halperin, E., Crisp, R. J., Husnu, S., Trzesniewski, K. H., Dweck, C. S., & Gross, J. J. (2012). Promoting intergroup contact by changing beliefs: Group malleability, intergroup anxiety, and contact motivation. *Emotion*, 12(6), 1192–1195. <https://doi.org/10.1037/a0028620>
- Halperin, E., Russell, A. G., Trzesniewski, K. H., Gross, J. J., & Dweck, C. S. (2011). Promoting the Middle East peace process by changing beliefs about group malleability. *Science*, 333(6050), 1767–1769. <https://doi.org/10.1126/science.1202925>
- Halualani, R. T., Mendoza, S. L., & Drzewiecka, J. A. (2009). "Critical" junctures in intercultural communication studies: A review. *Review of Communication*, 9(1), 17–35. <https://doi.org/10.1080/15358590802169504>
- Holliday, A. R. (2010). Cultural descriptions as political cultural acts: An exploration. *Language and Intercultural Communication*, 10(3), 259–272. <https://doi.org/10.1080/14708470903348572>
- Holm, G., & Londen, M. (2010). The discourse on multicultural education in Finland: Education for whom? *Intercultural Education*, 21(2), 107–120. <https://doi.org/10.1080/14675981003696222>
- Jussim, L., & Harber, K. D. (2005). Teacher expectations and self-fulfilling prophecies: Knowns and unknowns, resolved and unresolved controversies. *Personality and Social Psychology Review*, 9(2), 131–155. https://doi.org/10.1207/s15327957pspr0902_3
- Kahn, D. T., ReifenTagar, M., Halperin, E., Bäckström, M., Vitriol, J. A., & Liberman, V. (2018). If they can't change, why support change? Implicit theories about groups, social dominance orientation and political identity. *Journal of Social and Political Psychology*, 6(1), 151–173. <https://doi.org/10.5964/jpspp.v6i1.752>
- Kimanen, A., Alisaari, J., & Kallioniemi, A. (2019). In-service and pre-service teachers' orientations to linguistic, cultural and worldview diversity. *Journal of Teacher Education and Educators*, 8(1), 35–54.
- Kunter, M., Frenzel, A., Nagy, G., Baumert, J., & Pekrun, R. (2011). Teacher enthusiasm: Dimensionality and context specificity. *Contemporary Educational Psychology*, 36(4), 289–301. <https://doi.org/10.1016/j.cedpsych.2011.07.001>
- Leh, J. M., Grau, M., & Guiseppe, J. A. (2015). Navigating the development of pre-service teachers' intercultural competence and understanding of diversity: The benefits of facilitating online intercultural exchange. *Journal for Multicultural Education*, 9(2), 98–110. <https://doi.org/10.1108/JME-12-2014-0042>

- Leslie, L. M., Bono, J. E., Kim, Y. S., & Beaver, G. R. (2020). On melting pots and salad bowls: A meta-analysis of the effects of identity-blind and identity-conscious diversity ideologies. *Journal of Applied Psychology, 105*(5), 453–471. <https://doi.org/10.1037/apl0000446>
- Levontin, L., Halperin, E., & Dweck, C. S. (2013). Implicit theories block negative attributions about a longstanding adversary: The case of Israelis and Arabs. *Journal of Experimental Social Psychology, 49*(4), 670–675. <https://doi.org/10.1016/j.jesp.2013.02.002>
- Levy, S. R., Stroessner, S. J., & Dweck, C. S. (1998). Stereotype formation and endorsement: The role of implicit theories. *Journal of Personality and Social Psychology, 74*(6), 1421–1436. <https://doi.org/10.1037/0022-3514.74.6.1421>
- Ludlow, L. H., Enterline, S. E., & Cochran-Smith, M. (2008). Learning to teach for social justice-beliefs scale: An application of Rasch measurement principles. *Measurement and Evaluation in Counseling and Development, 40*(4), 194–214. <https://doi.org/10.1080/07481756.2008.11909815>
- McDonald, M., & Zeichner, K. (2009). Social justice teacher education. In W. Ayers, T. Quinn, & D. Stovall (Eds.), *The handbook of social justice in education* (pp. 595–610). Taylor and Francis.
- Morris, M. W., Chiu, C. Y., & Liu, Z. (2015). Polycultural psychology. *Annual Review of Psychology, 66*, 631–659. <https://doi.org/10.1146/annurev-psych-010814-015001>
- Muthén, L. K., & Muthén, B. O. (1998–2017). *Mplus User's Guide* (8th ed.). Muthén & Muthén.
- Nieto, S. (Ed.). (2005). *Why we teach*. Teachers College Press.
- Official Statistics of Finland (2018). *Population structure* [e-publication]. Statistics Finland. Retrieved from http://www.stat.fi/til/vaerak/index_en.html. Accessed March 3, 2021
- Osborn, H. J., Sosa, N., & Rios, K. (2020). Perceiving demographic diversity as a threat: Divergent effects of multiculturalism and polyculturalism. *Group Processes & Intergroup Relations, 23*(7), 1014–1031. <https://doi.org/10.1177/1368430219880606>
- O'Sullivan, H. (2013). The essentiality of essentialism and the symbolic violence of critical discourse analysis. *Journal of Multicultural Discourses, 8*(2), 157–164. <https://doi.org/10.1080/17447143.2013.799674>
- Pedersen, A., Paradies, Y., & Barndon, A. (2015). The consequences of intergroup ideologies and prejudice control for discrimination and harmony. *Journal of Applied Social Psychology, 45*(12), 684–696. <https://doi.org/10.1111/jasp.1233>
- Perry, L. B., & Southwell, L. (2011). Developing intercultural understanding and skills: Models and approaches. *Intercultural Education, 22*(6), 453–466. <https://doi.org/10.1080/14675986.2011.644948>
- Petrović, D. S., Jokić, T., & Leutwyler, B. (2016). Motivational aspects of teachers' intercultural competence: Development and psychometric evaluation of new scales for the assessment of motivational orientation. *Psihologija, 49*(4), 393–413.
- Räsänen, R. (2009). Teachers' intercultural competence and education for global responsibility. In M.-T. Talib, J. Loima, H. Paavola, & S. Patrikainen (Eds.), *Dialogs on diversity and global education* (pp. 29–50). Peter Lange.
- Rattan, A., & Georgeac, O. A. M. (2017). Understanding intergroup relations through the lens of implicit theories (mindsets) of malleability. *Social & Personality Psychology Compass, 11*(4), e12305. <https://doi.org/10.1111/spc3.12305>
- Rissanen, I. (2021). School principals' diversity ideologies in fostering the inclusion of Muslims in Finnish and Swedish schools. *Race Ethnicity and Education, 24*(3), 431–450. <https://doi.org/10.1080/13613324.2019.1599340>
- Rissanen, I., & Kuusisto, E. (2022). Kulttuurienvälisen valmiuksien perustaa tutkimassa: opettajien arkteoriat ja orientaatiot. *Psykologia, 57*(2), 140–156.
- Rissanen, I., & Kuusisto, E. (2023). The role of growth mindset in shaping teachers' intercultural competencies: A study among Finnish teachers. *British Educational Research Journal, 51*(1), 1002/berj.3875. <https://doi.org/10.1002/berj.3875>
- Rissanen, I., Kuusisto, E., Timm, S., & Kaukko, M. (2023). Diversity beliefs are associated with orientations to teaching for diversity and social justice: A study among German and Finnish student teachers. *Teaching and Teacher Education, 123*, 103996. <https://doi.org/10.1016/j.tate.2022.103996>
- Rissanen, I., Kuusisto, E., & Tirri, K. (2015). Finnish teachers' attitudes to Muslim student integration. *Journal for the Scientific Study of Religion, 54*(2), 277–290. <https://doi.org/10.1111/jssr.12190>
- Rosenthal, L., & Levy, S. R. (2010). The colorblind, multicultural, and polycultural ideological approaches to improving intergroup attitudes and relations. *Social Issues and Policy Review, 4*(1), 215–246. <https://doi.org/10.1111/j.1751-2409.2010.01022.x>

- Rosenthal, L., & Levy, S. R. (2012). The relation between polyculturalism and intergroup attitudes among racially and ethnically diverse adults. *Cultural Diversity and Ethnic Minority Psychology, 18*(1), 1–16. <https://doi.org/10.1037/a0026490>
- Rosenthal, L., Levy, S. R., Katser, M., & Bazile, C. (2015). Polyculturalism and attitudes toward Muslim Americans. *Peace and Conflict: Journal of Peace Psychology, 21*(4), 535–545. <https://doi.org/10.1037/pac0000133>
- Rosenthal, L., Levy, S. R., London, B., & Lewis, M. A. (2016). Polyculturalism among undergraduates at diverse universities: Associations through intergroup anxiety with academic and alcohol outcomes. *Analyses of Social Issues and Public Policy, 16*, 193–226. <https://doi.org/10.1111/asap.12121>
- Rosenthal, L., Levy, S. R., & Moss, I. (2012). Polyculturalism and openness about criticizing one's culture: Implications for sexual prejudice. *Group Processes & Intergroup Relations, 15*(2), 149–165. <https://doi.org/10.1177/1368430211412801>
- Ryan, C. S., Casas, J. F., & Thompson, B. K. (2010). Interethnic ideology, intergroup perceptions, and cultural orientation. *Journal of Social Issues, 66*(1), 29–44. <https://doi.org/10.1111/j.1540-4560.2009.01631.x>
- Rydell, R. J., Hugenberg, K., Ray, D., & Mackie, D. M. (2007). Implicit theories about groups and stereotyping: The role of group entitativity. *Personality and Social Psychology Bulletin, 33*(4), 549–558. <https://doi.org/10.1177/0146167206296956>
- Sanger, M. N., & Osguthorpe, R. D. (2011). Teacher education, preservice teacher beliefs, and the moral work of teaching. *Teaching and Teacher Education, 27*(3), 569–578. <https://doi.org/10.1016/j.tate.2010.10.011>
- Schachner, M. K., Schwarzenhal, M., Moffitt, U., Civitillo, S., & Juang, L. (2021). Capturing a nuanced picture of classroom cultural diversity climate: Multigroup and multilevel analyses among secondary school students in Germany. *Contemporary Educational Psychology, 65*, 101971.
- Skott, J. (2014). The promises, problems and prospects of research on teachers' beliefs. In H. Fives & M. G. Gill (Eds.), *International handbook of research on teachers' beliefs* (pp. 13–30). Routledge.
- Thornberg, R. (2008). The lack of professional knowledge in values education. *Teaching and Teacher Education, 24*(7), 1791–1798. <https://doi.org/10.1016/j.tate.2008.04.004>
- Tirri, K. (2014). The last 40 years in Finnish teacher education. *Journal of Education for Teaching, 40*(5), 600–609. <https://doi.org/10.1080/02607476.2014.956545>
- Tjipto, S., & Bernardo, A. B. I. (2019). Constraints in the meanings of lay theories of culture in a culturally homogeneous society: A mixed-methods study on multiculturalism and polyculturalism in Wonosobo, Indonesia. *Cogent Psychology, 6*(1), 1569835–1569996. <https://doi.org/10.1080/23311908.2019.1569835>
- Tochon, F. V. (2009). From video cases to video pedagogy: A framework for video feedback and reflection in pedagogical research praxis. In R. Goldman, R. Pea, B. Barron, & S. J. Derry (Eds.), *Video research in the learning sciences* (pp. 53–65). Taylor & Francis Group.
- Wolsko, C., Park, B., & Judd, C. M. (2006). Considering the tower of babel: Correlates of assimilation and multiculturalism among ethnic minority and majority groups in the United States. *Social Justice Research, 19*(3), 277–306.
- Wolsko, C., Park, B., Judd, C. M., & Wittenbrink, B. (2000). Framing interethnic ideology: Effects of multicultural and color-blind perspectives on judgments of groups and individuals. *Journal of Personality and Social Psychology, 78*(4), 635–654. <https://doi.org/10.1037/0022-3514.78.4.635>
- Yogeeswaran, K., Verkuyten, M., & Ealam, B. (2020). A way forward? The impact of interculturalism on intergroup relations in culturally diverse nations. *Group Processes & Intergroup Relations, 24*(6), 945–965. <https://doi.org/10.1177/1368430220918651>
- Zilliacus, H., Paulsrud, B., & Holm, G. (2017). Essentializing vs. non-essentializing students' cultural identities: Curricular discourses in Finland and Sweden. *Journal of Multicultural Discourses, 12*(2), 166–180. <https://doi.org/10.1080/17447143.2017.1311335>

Publisher's Note Springer Nature remains neutral with regard to jurisdictional claims in published maps and institutional affiliations.

Dr. Inkeri Rissanen is lecturer of multicultural education at the Faculty of Education and Culture of Tampere University. She uses social psychological perspectives to study intercultural education, particularly teachers' intercultural competencies. Her research also covers religions and worldviews in education.

Dr. Elina Kuusisto is a University Lecturer (diversity and inclusive education) at the Faculty of Education and Culture, Tampere University. She holds the title of Docent at the University of Helsinki. Her academic writings deal with teachers' professional ethics and school pedagogy, with a special interest in purpose in life, moral sensitivities, and a growth mindset.

Jake McMullen is an Associate Professor of Mathematics Education at the Department of Teacher Education of the University of Turku. His research interests involve examining individual differences in mathematical development and the design of learning environments that support flexible mathematical thinking.