



**UNIVERSITY
OF TURKU**

The Impact of Material Selection on Plain Bearings in Challenging Operating Conditions

Effects on Agricultural machinery

Department of Mechanical and Materials engineering

Bachelor's thesis

Author:

Liisi Jokinen

8.5.2025

Turku

The originality of this thesis has been checked in accordance with the University of Turku quality assurance system using the Turnitin Originality Check service.

Bachelor's thesis

Subject: Materials Engineering

Author: Liisi Jokinen

Title: The Impact of Material Selection on Bearings in Challenging Operating Conditions – Effects on Agricultural Machinery

Supervisors: Dr. Emilia Palo (UTU) and Jere Kettunen (OEM Finland Oy)

Number of pages: 33 pages

Date: 13.5.2025

This bachelor's thesis is conducted in collaboration with OEM Finland Oy and examines the role of strategic material selection in plain bearing applications for agricultural machinery. This thesis evaluates the transition from traditional metallic bearings to high-performance polymer bearings.

The study addresses the vulnerability of mechanical joints to debris, shocks and insufficient lubrication, which often result in accelerated wear and operational failures. The primary focus is to examine how material choices, specifically within the Iigus® Iglidur®-range, can mitigate these environmental effects and enhance machinery longevity.

The findings demonstrate that fiber-reinforced polymers with integrated solid lubricants achieve a maintenance-free operation, preventing the formation of abrasive pastes common in traditional metallic plain bearing systems. The economic and environmental impacts are substantial, involving a significant reduction in maintenance labor hours, lubricant costs, and environmental pollution. This work provides OEM Finland Oy and Iigus® GmbH with a technical framework to promote sustainable, maintenance-free components that decrease total life cycle costs for agricultural operators.

Keywords: plain bearings, agricultural machinery, maintenance-free, high-performance plastics, self-lubrication

Kandidaatintutkielma

Oppiaine: Materiaalitekniikka

Tekijä: Liisi Jokinen

Otsikko: Materiaalivalintojen vaikutus laakereihin haastavissa käyttöolosuhteissa – Vaikutukset maatalouskoneisiin

Ohjaajat: FT Emilia Palo (UTU) and Jere Kettunen (OEM Finland Oy)

Sivumäärä: 33 pages

Päivämäärä: 13.5.2025

Tämä kandidaatintutkielma on tehty toimeksiantona OEM Finland Oy:lle, ja siinä tarkastellaan strategisten materiaalivalintojen merkitystä maatalouskoneiden liukulaakerisovelluksissa. Tutkimuksessa arvioidaan siirtymää perinteisistä metalliliukulaakereista korkean suorituskyvyn polymeerilaakereihin keskittyen erityisesti Iguksen Iglidur® -tuotesarjaan.

Tutkimus käsittelee mekaanisten nivelpisteiden alttiutta lialle, iskuille ja puutteelliselle voitelulle, jotka johtavat usein kiihtyvään kulumiseen ja toimintahäiriöihin pelloilla. Tulokset osoittavat, että kuitulujitetut polymeerit, joihin on lisätty kiinteitä voiteluaineita, mahdollistavat huoltovapaan toiminnan est.ämällä perinteisille voideltaville liukulaakereille tyypillisten hiovien tahnojen muodostumisen

Taloudelliset ja ympäristölliset vaikutukset ovat merkittäviä, ja niihin sisältyvät huoltotyötuntien, voiteluainekustannusten sekä ympäristön saastumisen väheneminen. Tämä työ tarjoaa OEM Finland Oy:lle ja Icus® GmbH:lle teknisen viitekehyksen kestävien ja huoltovapaiden komponenttien edistämiseen, mikä vähentää maatalousyrittäjien kokonaislinkaarikustannuksia.

Keywords: liukulaakerit, maatalouskoneet, huoltovapaus, korkean suorituskyvyn muovit, itsevoitelu

Table of contents

| | | |
|----------|--|-----------|
| 1 | Introduction | 5 |
| 2 | Fundamentals of Plain Bearings and Tribology | 7 |
| 3 | Materials in Plastic Plain Bearings | 13 |
| 3.1 | Classification and Properties of Bearing Polymers | 13 |
| 3.2 | Reinforcements of High-performance Polymer Bearings | 15 |
| 3.3 | Self-Lubrication Mechanism and Solid Lubricants | 17 |
| 4 | Analysis of Material Solutions in Agricultural Applications | 19 |
| 4.1 | Iigus® Material Selection for Agricultural Machinery | 19 |
| 4.2 | Comparative Study of Iigus® vs. Traditional materials | 20 |
| 4.3 | Case Studies and Successful Implementations in Agriculture | 22 |
| 5 | Environmental and Economic Benefits of Plastic Plain Bearings | 24 |
| 5.1 | Economic Benefits of Plastic Plain Bearings | 24 |
| 5.2 | Environmental Benefits of Plastic Plain Bearings | 25 |
| 5.3 | Performance Trade-offs during Material Selection | 27 |
| 6 | Conclusions | 29 |
| | References | 31 |

1 Introduction

Modern agricultural and mobile machinery are required to operate reliably under harsh environmental conditions that are challenging for mechanical components. In these applications, pivot points and bearing connections are constantly exposed extreme environmental factors such as contaminants like debris and dirt [1]. Agricultural equipment must endure frequent shocks and vibrations, heavy loads, and irregular maintenance schedules [1]. The agricultural industry has traditionally relied on heavily lubricated metal bearings but the growing demand for higher operational efficiency, shorter maintenance downtime and environmental sustainability has changed the perspective on material choices for plain bearings [2].

The fundamental problem in bearing design for agricultural applications is the accelerating wear caused by contamination and insufficient lubrication [3]. Lubricants easily mix with environmental particles such as grit or soil and form an abrasive paste that can degrade the bearing system [3]. This thesis studies how strategic material choices can mitigate these effects and extend the service life of these components and machinery.

This thesis focuses exclusively on plain bearings, specifically flanged bearings and sleeve bearings, excluding rolling-element bearings. The material evaluation focuses on high-performance polymers and composites, particularly those intended for dry-running applications. This study aims to address the following research questions:

1. How do operating conditions in agriculture influence material choice?
2. Which plastic/composite bearing materials are suitable for these conditions?
3. How do polymer-based plain bearings perform compared to metallic bearings, and what are the economic/environmental effects?

One of the objectives of this study is also to address the prevailing misconception surrounding the use of plastic bearings in demanding environments. While engineering plastics are often perceived as fragile materials in such operations, this study provides

a technical comparison to update the current understanding of high-performance plastics and demonstrate their viability.

This bachelor's thesis has been conducted in collaboration with OEM Finland Oy. To provide practicality this study utilizes high-performance polymer bearings from Iigus® GmbH as technical examples. These components serve as a point of comparison for maintenance-free solutions compared to traditional metallic alternatives. This thesis utilized artificial intelligence (Gemini by Google) for linguistic refinement and structural formatting.

2 Fundamentals of Plain Bearings and Tribology

A plain bearing is the simplest type of bearing, designed to support loads while allowing constrained motion between two surfaces. It is a broad technical term for a bearing without rolling elements [4]. Typically cylindrical in shape, these components are utilized to reduce friction and wear on the working surfaces [5]. They are particularly suitable for high loads, harsh environmental conditions, and low speeds [4]. In addition to supporting loads, plain bearings ensure smoothness and stability of motion. Instead of utilizing balls or rollers to reduce friction, they rely on direct sliding contact between the bearing surface and the counter-surface [4]. This design makes them simpler to build, more insensitive to shock and easier to integrate with other components.

Depending on application and design needs, plain bearings are available in various designs and material variants [4]. Their versatility allows for use in a wide range of industries, from simple household mechanisms to advanced technological devices and systems that operate in extreme conditions [4]. While plain bearings are utilized in many different industries, they are critical in the heavy-duty vehicle design in agricultural, construction, forestry and mining equipment [2].

Figure 1 illustrates the use of plain bearings in a tractor's assembly, with numbered indicators highlighting critical pivot points. For instance, the front axle (13) utilizes Iglidur® Q2 bearings for high load resistance, while stub axle (14) requires materials like Iglidur® P that are insensitive to shocks and moisture [6]. High stress areas such as the drivetrain (12) rely on heat-resistant plain bearings like Iglidur® Z [6]. Cabin applications like the pedals (11) and steering column (6) prioritize low friction and maintenance-free operation and utilize Iglidur® J [6]. Furthermore, the use of general-purpose bearings (Iglidur® G300) in the hood and door hinges (1, 3) demonstrates the ability of plastic composites to tolerate edge loads better than traditional metallic alternatives [6]. Figure 1 illustrates the placement of these plain bearings in a tractor assembly.



Figure 1. Application points of polymer plain bearings in a tractor assembly. Image reproduced with permission from Igus GmbH [6]. Copyright 2022 Igus GmbH.

On-road vehicles have bearings in suspension components, engines, transmissions, drivetrains and steering components [2]. Heavy-duty off-road equipment has auxiliary motions specific to that equipment in addition to the same general components [2]. For example, an agricultural combine harvester has many mechanical functions in its grain threshing system, and earthmoving machinery has mechanical and hydraulic front loader buckets and excavators, all of which require multiple bearings to ensure frictionless, mechanical motion and smooth operation [2]. Table 1 shows where plain bearings are found in agricultural equipment.

Table 1. Typical plain bearing application points in agricultural equipment [7].

| Agricultural Equipment | Component / Pivot Point |
|--------------------------------|---|
| Tractors and their attachments | Front axle, drive train, tractor strut and steering, rock shaft, accessory shaft and wiper arms |
| Cultivator | Overload elements, folding mechanisms and depth control linkages |
| Wagon or trailers | Axle pivot points, equalizer and pivot hinges |
| Seeder and planter | Coulter pivots, row unit parallel linkages |
| Fertilizer spreader | Agitator shafts, adjustment slides and shutters |

There are many types of plain bearings, but all consist of a lubricated metal sleeve designed to reduce friction between the two sliding surfaces [2]. To understand their mechanical function, plain bearings must be viewed as part of a system. As illustrated in Figure 2 a typical bearing consists of three main structural elements. Each of these elements has a specific function and must be properly selected for the operating conditions [4]. The housing (or casing) is the stationary part that supports the bearing. Inside the housing is the sliding sleeve which is in direct contact with the rotating shaft journal. The third element is the shaft journal which is the surface of the shaft that interacts with the sleeve and performs sliding motion [4].

The radial view in Figure 2 highlights the critical interaction between these components, where a traditional lubricated system relies on an oil film to separate the shaft from the bearing surface [8]. While the basic structural principles remain the same for a self-lubricating plastic bearing, the primary difference is the lack of lubricant in plastic plain bearings. The structural elements of a plain bearing and the lubrication principle of a traditional metallic plain bearing are presented in Figure 2.

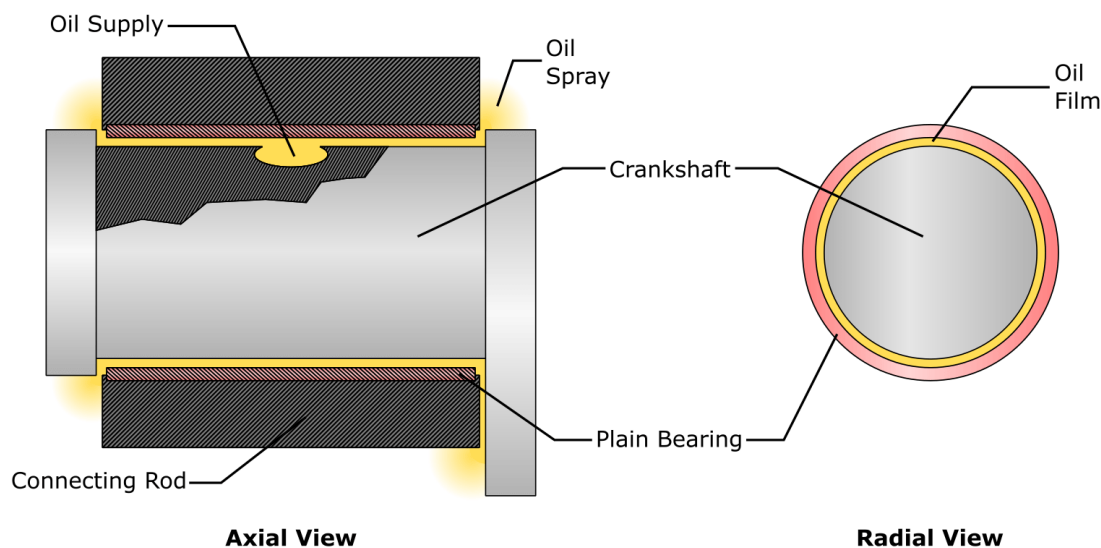

Figure 2. Structural elements and lubrication principle of a plain bearing system in axial and radial views. Image reproduced with permission from saVRee [8]. Copyright 2026 saVRee.

The performance of the plain bearing is highly dependent on the shaft, which operates as the counter-surface for the bearing. The interaction between the bearing surface and the shaft determines the efficiency and lifespan of the component. The shaft must have specific mechanical and thermal properties to effectively support and transmit forces within the system [5]. It must exhibit sufficient structural rigidity to prevent deformation under the surface pressure generated at the interface of the shaft and the bearing material [5]. In addition the shaft must resist bending, as excessive deflection can generate angular loads that are harmful to the proper functioning of the bearing [5]. It should have the best thermal conductivity as well as the highest thermal diffusivity possible to minimize temperature variations across the bearing surface and therefore prevent overheating [5]. It is important to notice that plastic bearings offer more options for shaft materials than metallic bearings [9]. For example, bronze bearings require the shaft to be harder than the bearing itself, and ball bearings require the shaft to be harder and smoother than the bearing [9]. Plastic bearings allow less expensive options as they can operate on a variety of shaft materials [9].

To evaluate the performance of plain bearings, it is essential to understand the tribological processes that occur at the sliding surfaces. Tribology is defined as a field of multidisciplinary science that examines the friction, wear and lubrication of interacting

surfaces that are in relative motion [10]. In the case of plain bearings, these elements form a system where the lubrication regime has a direct effect on friction and therefore the rate of material wear [10].

Wear is the progressive damage or loss of material from solid surfaces due to relative motion [11]. Wear is often accelerated by friction, heat and chemical interactions. It is the major cause of material wastage and loss of mechanical performance [10]. In agricultural applications, abrasive wear is the most common mechanism due to constant contact with soil and grit. Abrasive wear occurs when a solid object is loaded against particles of a material that have equal or greater hardness than the surface itself [11].

Friction is the resistance to motion that occurs when two surfaces interact in relative motion [12]. In plastic bearings, the coefficient of friction is not a constant value but is highly dependent on operating conditions such as surface pressure (p), sliding speed (v), and the temperature of the contact surface [12]. One of the most critical factors for friction is the surface finish of the counter-face [12]. If the counter-face is too smooth, friction increases due to adhesion, whereas if the surface is too rough it can lead to increased wear through abrasive cutting [12].

A major concern with friction in plastic bearings is the generation of frictional heat [12]. Because plastics have significantly lower thermal conductivity than metals, they cannot dissipate heat effectively from the sliding surface [12]. This can lead to a rapid increase in local temperature, causing thermal expansion and, in extreme cases, the melting or seizure of the bearing [12]. To maintain stable operation, the heat generated by friction must be balanced with the bearing's ability to dissipate it, which is why the pressure-velocity (PV) limit is a fundamental design constraint for these materials [12].

Lubrication is a technique used to reduce friction and wear between the interacting surfaces in a plain bearing [13]. The lubricants can be a solid, fluid or plastic films such as oil or grease [13]. Traditionally, lubricants are categorized into three regimes: boundary, mixed and full-film lubrication [11]. In agricultural applications characterized

by frequent starts and stops and shock-load conditions, plain bearings often operate in the boundary lubrication regime where the lubricant film is too thin to prevent direct contact [8]. While traditional metallic bearings rely on external fluid lubrication to decouple the sliding surfaces, they are also highly susceptible to failure if the lubricant film breaks [13]. In polymer-based plastic bearings, solid lubricants are embedded to the material matrix to make them self-lubricating [13]. The self-lubricating effect ensures stable performance without the problems that are faced with traditional metallic plain bearings [13].

The selection of plain bearings instead of rolling-element bearings is a strategic design decision driven by specific operational requirements of the application. Due to their structural simplicity and lightweight design, plain bearings are more resistant to vibrations and shock loads [14]. In agricultural applications this toughness is a crucial factor as it prevents machine failures. Furthermore, plain bearings are usually less sensitive to contaminants such as dirt and dust which is a highly desired feature in agricultural applications [14]. Unlike many traditional bearing types, modern self-lubricating plain bearings do not need constant re-lubrication [14]. Despite their advantages, the sliding motion of plain bearings introduces some physical constraints and the most significant of which is increased frictional heat. Continuous surface contact can lead to rapid temperature increases especially at high speeds which can therefore exceed the material's thermal limits [14]. Additionally plain bearings typically require larger drive torques due to higher starting friction and tilting moments can become a problematic if loads are applied at an offset [14].

3 Materials in Plastic Plain Bearings

With the continuous advancements in materials science, polymer and composite bearings have emerged as high-performance alternatives to traditional metallic bearing materials [15]. The chemical and structural composition behind bearing polymers and composites plays a major role in determining the performance, durability and reliability of plain bearings under harsh conditions [16]. In the context of material science, the focus is on developing materials that reduce friction, resist wear and support loads without traditional lubrication [16].

3.1 Classification and Properties of Bearing Polymers

Plastics are synthetic macromolecules (polymers) consisting of linked molecular chains. Based on the structural and physical properties of plastics they are classified into thermoplastics, duroplasts (thermosets) and elastomers [15]. For plain bearing applications thermoplastics and duroplasts are most utilized because of their dimensional stability [15]. The primary difference between these two groups is that duroplasts cannot be deformed after hardening, while thermoplastics can be melted and reshaped [15].

While both groups are used in bearing technology, thermoplastics are more frequently chosen in modern engineering. This preference is due to easier processing methods, such as injection moulding, where the material is in granular form and is melted and then poured or injected into prefabricated forms [15]. The thermoplastic matrix allows the integration of various additional materials, improving the specifications of the component [15].

Technical plastics, also known as engineering plastics, form a subgroup of thermoplastics positioned between standard and high-performance plastics in terms of both cost and properties [17]. Examples of technical plastics utilized in plain bearings are shown in Figure 2.

High-performance plastics (HPPs) are a subgroup of thermoplastics that can withstand harsh conditions while retaining their desired properties [17]. High-performance polymers exhibit better thermal stability, chemical resistance, and mechanical

properties [17]. These plastics are selected when standard or technical plastics cannot meet the desired requirements [17]. Examples of high-performance plastics utilized in plain bearings are shown in Figure 2.

Motion plastics or tribo-polymers are a specialized group of high-performance thermoplastics optimized for applications involving friction and wear [17]. These materials are designed to exceed the limitations of standard or technical plastics, offering a corrosion-free and low-maintenance alternative [17]. In harsh environments like vertical farming and agricultural automation, motion plastics are particularly effective due to their high resistance to dirt, soil and dust [17]. Examples of motion plastics utilized in plain bearings are shown in Figure 2.

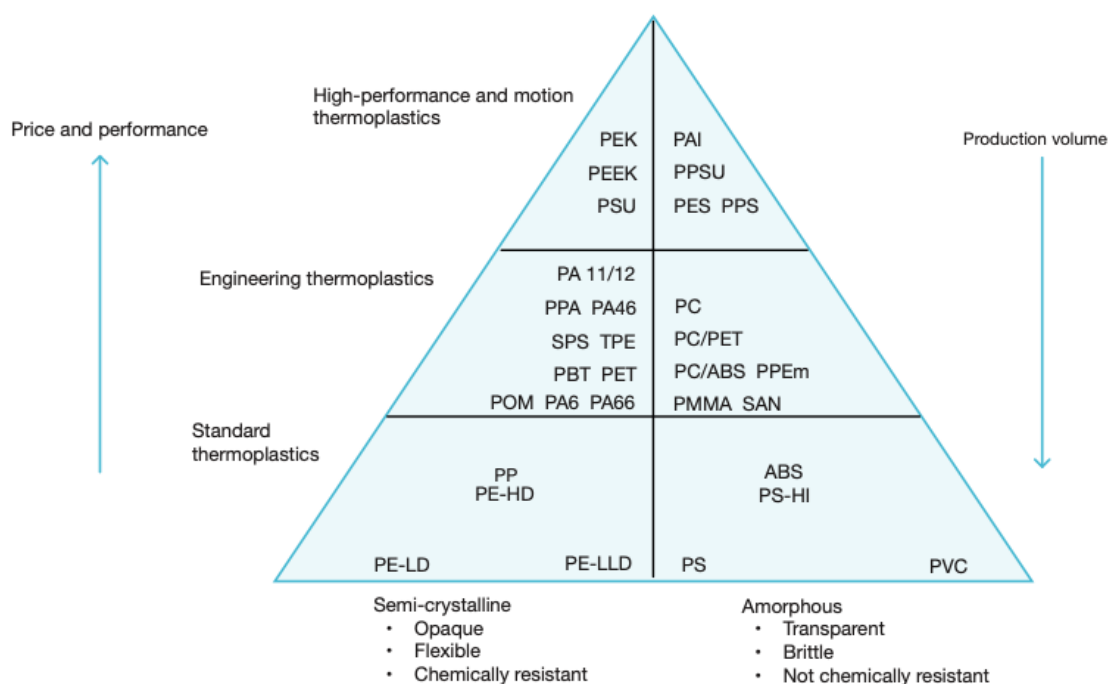

Figure 3. Classification pyramid of thermoplastics based on performance, price and production volume. Modified from Igus GmbH [15]. Copyright 2022 Author Unknown, published by Igus GmbH.

While the classification provides a theoretical framework, the choice of material in engineering is driven by specific environmental demands. In practical applications, standard thermoplastics are rarely sufficient for plain bearings due to the high demands for temperature and chemical resistance [15]. In these environments, a material's ability to maintain its toughness and hardness is more critical than its absolute melting point [15]. Consequently, materials like Polyoxymethylene (POM) and Polyamide 66

(PA66) are popular for general applications due to their balance of cost and performance [15].

POM is characterized by low wear, dimensional stability and creep resistance, though its use is restricted to temperatures below 100°C and is avoided in unventilated spaces like vehicle interiors due to the potential releases of formaldehyde under certain circumstances [15]. PA66 is often reinforced with fibers, such as glass or carbon, which improves its wear resistance and mechanical strength compared with POM [15]. However, machining and manufacturing large components from PA66 is complicated. PA66 and POM are used in less temperature-sensitive applications and they are lower cost [15].

Polymers PPS, PPS-U, PAI and PEEK are among the materials that can be used in demanding applications [15]. These polymers are often used in plain bearings because they can withstand temperatures over 200°C [15]. Furthermore, these materials are resistant to chemicals, have good tribological specifications and offer good strength values [15]. For the most demanding applications, high-performance polymers such as polyether ether ketone (PEEK) are utilized [15]. PEEK is used for high-temperature applications, it has exceptional chemical resistance and its tribological specifications are great [15]. It is used wherever metal bearings need protection against corrosion and lubrication failure [15].

3.2 Reinforcements of High-performance Polymer Bearings

The performance of polymer-based bearings is not solely dependent on the base polymer matrix but is significantly enhanced by the incorporation of various fillers and reinforcing fibers [9]. These additives are essential because they modify the friction, wear, and mechanical properties of the composite to meet specific requirements [9]. Although pure polymer may offer low friction, it lacks the necessary load capacity and heat resistance [9]. Therefore, the internal structure of a polymer-based bearing composite is typically a combination of the polymer matrix, reinforcing fibers and solid lubricants [9].

Different applications require different features for plain bearing materials. When the base polymer is modified by adding reinforcement, it improves the durability of the bearing [18]. Reinforcements used in plain bearings are fibers and fillers. Reinforcing materials are uniformly distributed in the plain bearing over the entire cross section [13]. Fibers and fillers strengthen the material so that it can withstand high forces or edge loads and can be used continuously [13].

The motive for integrating reinforcements is to get the best load-bearing capacity, uniform pressure distribution and best tribological performance per application [18]. By reinforcing the polymer matrix, it is possible to create materials that maintain their dimensional stability even when subjected to loads that exceed the limits of standard thermoplastics [18]. This feature is desirable in plain bearings that are used for agricultural applications.

The choice of reinforcement material depends on the base polymer, application of the plain bearing and the material of the shaft/counter-face [13]. The available reinforcements span inorganic fibers, metallic fillers and organic (polymer or carbon-based) fillers including surface-modified variants for enhanced performance [19].

Metallic fillers such as Al, Cu, Pb, Al_2O_3 , Bronze and Cu_2O are mainly used to enhance load capacity and wear resistance, whereas carbon-based reinforcements are particularly effective in reducing wear and friction [18]. Inorganic and polymer fillers and surface-treated reinforcements tailor tribological and thermal behaviour [18]. Glass and carbon fibers are the most common reinforcements used to improve mechanical stability and load-bearing capacity [18]. Glass fibers are particularly effective in improving heat resistance and strength, while carbon fibers are often used to improve wear resistance [18]. Table 2 provides an overview of typical reinforcement options for polymer plain bearings.

Table 2. Reinforcement materials used in polymer-based bearings [18,19]

| Metallic fillers | Carbon-based reinforcements | Inorganic/polymer fillers | Surface-treated reinforcements |
|--------------------------------|------------------------------------|----------------------------------|--|
| Al | Graphite | SiO ₂ | Glass Fibers |
| Cu | Graphene nanoplates | WS ₂ | Carbon Fibers |
| Pb | Carbon fibers | Talc- SiO ₂ | Modified Fillers |
| Al ₂ O ₃ | Carbon nanofibers (CNFs) | Natural Zeolite | PDA/ SiO ₂ Hybrid coatings on fabrics |
| Bronze | Carbon nanotubes (CNTs) | PEEK | Plasma-treated PTFE or POM |
| MgO | Aramid/Kevlar fibers | PI | Modified TiO ₂ |
| Ni | Graphite flakes | PA6 | Re-treated carbon fibers |
| ZnO | Carbon fabric | Epoxy | Re-treated glass fibers |

The reinforcement materials listed in Table 2 are selected based on the specific mechanical or thermal deficiencies of the base polymer to ensure that the plain bearing can withstand the demanding conditions of agricultural work. The most common reinforcement fibers in these applications are glass and carbon fibers [18].

If the reinforcement content is too high, the interactions between the polymer chains are disrupted and the matrix can no longer transfer loads effectively [18]. This overfilling can lead to a loss in tensile strength and toughness, making the material more brittle [18]. Achieving the optimal amount of base polymer and reinforcement material is crucial to ensure the durability and reliability of the bearing under harsh conditions [18].

3.3 Self-Lubrication Mechanism and Solid Lubricants

The functional superiority of composite and polymer-based bearings is fundamentally based on self-lubricating mechanisms that are embedded to the surface layer of the bearing's material during the manufacturing process [2]. The functional surface layer is typically porous or perforated and acts as a reservoir for the solid lubricants and the embedded lubrication is released by the relative motion between the shaft and the bearing surface [2]. As friction is generated at the motion points, it causes the embedded oil to be released and provides a layer of lubrication on the contact interface. The porous bearing surface reabsorbs the leftover grease or oil when the component is

at rest. Because these self-lubricating bearings do not lose or deteriorate their lubrication over time, they eliminate the necessity for regular manual service intervals [2]. This maintenance-free characteristic is critical for maximizing equipment uptime and productivity while minimizing long-term operational and maintenance costs [2].

The inherent dry sliding properties of composite bearings eliminate the need for external lubrication in most applications [2]. However, the specific lubrication strategy depends on the base polymer. PTFE-based bearings operate without the external lubrication [2]. In contrast, polyoxymethylene (POM) composite bearings require an initial film of lubricant during assembly [2]. While both material types exhibit similar friction coefficients ranging from 0.03-0.25, POM-based composites often achieve a lower coefficient due to the presence of the initial lubricating film [2].

PFTE (Teflon) provides the lowest possible coefficient of static and dynamic friction making it ideal for applications requiring smooth motion [20]. Molybdenum disulphide (MoS_2) enhances the surface hardness of the composite and is effective in high-loads, vacuum or dry conditions where fluid lubricants might evaporate [20]. Graphite is often utilized in humid or underwater environments as its lubricating properties are enhanced by the presence of water vapor [20].

4 Analysis of Material Solutions in Agricultural Applications

This chapter transitions from theoretical principles to practical applications. It evaluates the technical specifications for material selection, compares plastic performance against traditional metals, and presents case studies. The case studies demonstrate how plastic solutions have improved operational life and reduced maintenance requirements in agricultural machinery.

4.1 Igus® Material Selection for Agricultural Machinery

For agricultural applications, the Iglidur®-series from Igus® offers a variety of tribologically optimized high-performance polymers. These materials are characterized by a specialized composition that ensures high resilience, wear resistance and inherent self-lubricating properties [13]. Since a single universal material cannot fulfil the diverse requirements of all agricultural machinery, the Iglidur®-materials consist of various grades with individual strengths and technical specifications [21]. The primary advantages of these polymer plain bearings in agricultural applications include their ability to operate in dry-running conditions and their high resistance to dust, dirt and corrosion [21]. In addition, they offer significant mechanical stability, effective vibration dampening, and the ability to compensate for shaft misalignments [21]. Additionally, the manufacturing flexibility allows for custom components based on specific technical drawings, even in small production quantities [21].

To meet the diverse application requirements of agricultural machinery, the Iglidur® material range is classified according to specific performance criteria. Among the various options, Iglidur® G and Iglidur® J are the most widely used materials due to their versatile properties [22]. To provide a more comprehensive overview of the Iglidur®-materials and their specific role, the primary materials used in agricultural engineering and their typical applications are summarized in Table 3.

Table 3. Iglidur® material characteristics and typical agricultural applications [22],[23] .

| Material | Key Characteristics | Typical Agricultural Application |
|----------------------|---|--|
| Iglidur® G | Versatile, high wear resistance, cost-effective | Pivot points in root ball transplanters, disc harrows, hay tedders, track width adjustments, power lifts, sowing coulters and general-purpose joints |
| Iglidur® J | Low friction, minimal moisture absorption | Reel bearing harvester, steering systems and pedals, milking arms, combine harvesters |
| Iglidur® P | High precision, low moisture absorption, cost-effective, high-pressure loads | Hydraulic cylinders |
| Iglidur® Q | Optimized for pivoting movements under extreme loads, low sensitivity to dirt | Heavy-duty axle bearings, trailers |
| Iglidur® Q2 | For high dynamic loads, dirt, high impact and shock loads | Front loader pivot points |
| Iglidur® Z | High thermal stability, resistance to edge pressures under high surface pressures | Chassis bearings/suspensions |
| Iglidur® UW | Cost-effective, excellent wear resistance in underwater applications | Rotary pumps |
| Iglidur® Q290 | Durable in soft shafts, insensitive to edge loads, cost-effective | Rugged pivoting applications and machinery that utilize soft shafts |

The material data for each material can be found from Iglidur® [23]. Table 3 demonstrates that material selection is a multi-criteria decision process. While Iglidur® G offers a solution for general use, specialized components like Iglidur® Q2 are essential for handling the unpredictable dynamic forces and shock loads for example in front loader operations [22]. This specialization ensures that each bearing point is optimized for its specific environmental and mechanical operations.

4.2 Comparative Study of Iglidur® vs. Traditional materials

To evaluate the suitability of plastic plain bearings for agricultural applications, they must be compared to traditional metallic bearing materials such as bronze and

hardened steel. The technical specifications and performance limits are summarized in Table 4. It is important to note that while the values for metallic materials assume a properly lubricated state, the values for Iglidur®-materials represent dry-running conditions.

The PV-value, defined as the product of sliding velocity (V) and surface pressure (P), serves as a critical indicator of the heat generated within the bearing system per unit of time [24]. Although the data in Table 5 suggests that metallic materials possess higher thermal limits, the operational context of agricultural machinery must be considered. Most pivot points in these applications operate at relatively low sliding speeds, which results in significantly lower frictional heat generation compared to high-speed industrial machinery [24]. The lower thermal thresholds of polymer bearings do not typically pose a limitation in field operations, as the generated heat remains well within the safe working parameters of the material.

Table 4. Comparative performance data of metallic and plastic plain bearings.

| Material | Coefficient of Friction (μ) | Max. PV-value (MPa • m/s) | Max. Surface Pressure (MPa) | Temp. Range (Long-term, °C) | Source |
|-------------------------|---|----------------------------------|------------------------------------|------------------------------------|---------------|
| Bronze (CW453K) | 0.05-0.25 | 2.8 | 120 | -40/+150 | [25] |
| Steel (GGB-SHB®) | 0.2 | 1.5 | 300 | -20/+150 | [26] |
| Iglidur® G | 0.08-0.15 | 0.42 | 80 | -40/+130 | [23] |
| Iglidur® J | 0.06-0.18 | 0.34 | 35 | -50/+90 | [23] |
| Iglidur® P | 0.06-0.21 | 0.39 | 50 | -40/+130 | [23] |
| Iglidur® Q | 0.05-0.15 | 0.55 | 100 | -40/+135 | [23] |
| Iglidur® Q2 | 0.22-0.42 | 0.70 | 120 | -40/+130 | [23] |
| Iglidur® Z | 0.06-0.14 | 0.84 | 150 | -100/+250 | [23] |
| Iglidur® UW | 0.15-0.35 | 0.11 | 40 | -50/+90 | [23] |
| Iglidur® Q290 | 0.14-0.26 | 0.70 | 55 | -40/+140 | [23] |

As demonstrated in Table 5, the technical data reveals significant functional differences between traditional metals and high-performance polymer bearings. Although metallic materials such as steel and bronze offer higher maximum PV-values and peak

temperature resistance, they are highly dependent on a persistent lubricant film to achieve these values [2]. In contrast, Iglidur®-materials maintain a consistently low coefficient of friction even under dry-running conditions, which is an advantage in the contaminated environments of agricultural operations.

A key observation from the data is the maximum surface pressure capacity. Special Iglidur®-materials such as Iglidur® Z and Iglidur® Q2 offer load carrying capacities that are comparable to bronze. This shows that polymer composites are no longer limited to light duty applications but can also support heavy loads found in agricultural equipment.

4.3 Case Studies and Successful Implementations in Agriculture

The theoretical advantages of polymer-based plain bearings are best demonstrated through documented field applications. This section examines how specific high-performance materials solve mechanical failures and reduce operating costs in modern agriculture. To provide a practical overview the Iglidur® material range is utilized to illustrate how these technical transitions are implemented in real machinery.

A primary observation across various machinery types, such as intensive cultivators and fertilizer applicators, is the significant reduction or total elimination of manual lubrication cycles. In applications like the Lemken Karat 9 cultivator manufactured by Lemken GmbH & Co. KG, traditional metallic bearings typically require up to an hour of manual labour daily for lubrication [27]. By implementing self-lubricating plastic bearings, this maintenance downtime is converted into productive operating time, directly increasing daily productivity and preventing operational failures by insufficient greasing [27].

Field data across different equipment, including yard loaders manufactured by Thaler GmbH & Co. KG, show that dry-running plastic bearings manage environmental contaminants more effectively than lubricated metal systems. These machines face

constant exposure to water, dirt and heavy impact loads that put the internal components at risk [28]. Traditionally metal bushings are used at the pivot points, but they were proved problematic in this application, because constant contact with moisture led to the metallic plain bearings to rust quickly [28]. Thaler replaced the metal bearings with Iglidur® G polymer-based bearings in almost all loader models [28]. The use of these plastic plain bearings simplified the cleaning process and prevented the build-up of abrasive contaminants [28].

Beyond contaminant management, polymer-based bearings offer major advantages in vibration damping and chemical resistance. In heavy-duty applications such as front loaders, these materials withstand mechanical shocks and edge loads better than rigid metallic alternatives, as the polymer matrix adapts to the shaft surface to distribute pressure more evenly. This mechanical resilience is further complemented by chemical stability, which is critical in precision farming [29]. For instance, in liquid nitrogen injection systems, such as the NitroGro applicators by J&M Manufacturing, polymer bearings resist the corrosive effects of fertilizers that would otherwise lead to the rapid degradation of steel components [29]. This chemical immunity, combined with maintenance-free operation, can extend the service life of complex linkage systems by several years while ensuring precise application.

The performance gains observed in these commercial examples align with broader, non-proprietary tribological studies regarding self-lubricating plastic bearings. Independent research into fibre-reinforced polymers, such as PTFE and carbon-filled thermoplastics, consistently confirms the phenomenon of a transfer film formation [30]. During operation, the bearing deposits a microscopic layer of solid lubricant onto the counter-surface, which stabilizes the coefficient of friction and reduces wear regardless of the specific brand of the material. Furthermore, general scientific findings on the high damping ratios of polymers support the industry observations that plastic bushings reduce noise and mechanical stress in pivot points compared to metallic equivalents [30]. By mirroring these independent scientific principles, the success of polymer transitions in agricultural machinery is validated as a robust engineering solution rather than a manufacturer-specific benefit.

5 Environmental and Economic Benefits of Plastic Plain Bearings

The transition from traditional metallic bearings to polymer-based bearings is a strategic decision that leads to operational efficiency and environmental responsibility [31]. This section evaluates how self-lubricating plastic plain bearings translate into measurable economic and environmental savings for operators and how they contribute to the broader goals of agriculture. In addition, this chapter discusses the technical trade-offs that dictate when metallic bearings are still the necessary choice for certain design requirements.

5.1 Economic Benefits of Plastic Plain Bearings

The implementation of self-lubricating plastic bearings as a replacement for traditional lubricated metal bearings reduces the annual costs of agricultural machinery [31]. This transition impacts three primary cost categories consisting of the direct lubricant costs, the personnel costs resulting from maintenance labour hours and annual maintenance expenses [31].

Some lubrication processes are automated, but most re-lubrication processes are performed manually by a grease gun [32]. This task involves multiple critical steps which collectively consume a significant amount of operational time [32]. For a single machinery unit, such as a cultivator from Lemken GmbH & Co. KG with 22 lubrication points maintained 40 times per year, the transition to maintenance-free bearings results in an annual time saving of approximately 14.7 hours [31]. When scaled to an industrial level such as the production of 7 500 units, the cumulative labour savings reaches up to 110 250 hours [31]. Assuming an average annual wage cost of 45 240 € per employee, this time saving represents an annual personnel cost reduction of 2 397 940 € [31].

Eliminating external lubrication by using plastic plain bearings results in significant direct and indirect savings [32]. The leading cause of bearing failure in harsh environments is lubricant contamination with solid particles and water [32]. The economic impact can be illustrated by the example of Lemken GmbH & Co. KG, where a fleet of 7500 cultivators is estimated to save around 33 tonnes of lubricant over a 15-

year service life with plastic plain bearings [31]. This transition resulted in direct lubricant cost savings of 660 000 € and simplified the design of the machines by eliminating complex auxiliary components such as lubrication hoses and manifolds [31]. The costs of lubrication extend to the proper disposal of used oils and greases, which can be approximately 20 percent of annual lubrication costs [32].

In addition to labour and lubricant savings, the reduction of machine downtime constitutes a major economic advantage. Improper bearing lubrication or relubrication is estimated to account for up to 50 percent of machine failures [32]. Unplanned machine downtime can cost hundreds of euros per hour in lost productivity [32]. Machine failure not only damages the plain bearing but for example shafts or even motors need to be replaced which can be expensive [32]. The use of plastic plain bearings allows predictable maintenance intervals and reduces the risk of unplanned and expensive downtime during critical operational periods.

5.2 Environmental Benefits of Plastic Plain Bearings

The transition to self-lubricating plastic plain bearings provides significant environmental advantages by eliminating the requirement for external lubricants and reducing the overall energy consumption. The global environmental impact of traditional lubrication is significant, with approximately 27 million tonnes of lubricating grease polluting the environment each year [33]. This amount represents almost 50 percent of all lubricants sold worldwide, posing a serious threat to natural resources, as one litre of oil can contaminate 1 000 000 litres of drinking water [33].

From a manufacturing perspective, the production of one cubic meter of plastic requires 50 percent less energy compared to the production of an equivalent volume of steel or aluminium [33]. In addition, the global oil demand for high-performance plastics is relatively small, accounting for only 0.5 percent of total oil consumption [33]. To further mitigate the carbon footprint of production, Igus utilizes green electricity and continues to replace older injection moulding machinery with modern units that are 40 percent more energy efficient [33]. Even within the manufacturing process, sustainability is prioritized, as 99 percent of the waste generated from faulty parts in the

manufacturing process is recycled [33]. Igus has also taken part in addressing the environmental challenges posed by PTFE that is used as a reinforcement material [33]. The chemicals in PTFE are difficult to degrade in nature and Igus has developed materials that are free from PTFE [33].

Because of the lightweight design of plastic plain bearings, significantly less drive energy is required for machinery movement [33]. This is a critical factor in mobile machinery as one-third of total fuel consumption is used to overcome friction in the engine, gearbox, tires and brakes [33]. By utilizing tribologically optimized materials with low friction coefficients, these losses are minimized. Furthermore, plastic plain bearings are corrosion-free which ensures they do not become soiled by a mixture of impurities and lubricants common in agricultural environments [33]. The precision of service life calculators, supported by laboratory testing, allows for accurate maintenance planning [33]. The predictability ensures that components are used for their maximum possible duration, reducing the frequency of replacements.

The final stage of the product lifecycle focuses on recycling the plastic materials. Igus facilitates the recycling of both its own technical plastics and those from other manufacturers, with over 235 000 kg of material recycled as of March 2026 [33]. This recovery is achieved through mechanical recycling, where plastics are shredded, melted and converted into recyclate without altering their chemical structure [33]. This allows for the manufacture of new plastic products. For unsorted and complex plastic waste, chemical recycling serves as an alternative by breaking the material into its original raw materials [33]. Igus has invested into a new technology called Hydrothermal Plastic Recycling Technology (HydroPRT), which utilizes water, high temperatures and pressure to convert plastic waste into crude oil within 30 minutes [33]. These recycling strategies ensure that technical plastics are re-used as best as possible, significantly reducing the demand for virgin resources and the environment from industrial waste [33].

5.3 Performance Trade-offs during Material Selection

Despite the economic and environmental advantages of plastic plain bearings, their selection over traditional metallic bearings involves technical trade-offs that must be evaluated based on the specific application requirements. The primary application area for composite and plastic plain bearings is low-speed, high-load applications in demanding environments [14]. In these conditions, such as in joints in heavy machinery, plastic bearings can meet or even exceed the dynamic load capacity of bronze and aluminium [2]. Hardened steel is stronger than composite and plastic plain bearings, but they require frequent lubrication and corrode easily [2]. In addition, plastic plain bearings provide excellent noise and vibration damping and handle uneven rotating loads more effectively than rigid brass components [2].

However, prominent physical limitations exist in plastic plain bearings, regarding surface speed and thermal management. Plastic plain bearings are usually incompatible for high-speed shafts, with many material grades limited to surface speeds between 0.4 and 1.5 m/s in rotating movement [34]. These surface speeds are limit values assuming the lowest pressure loads on the bearing [34]. In practice, these values are not achievable due to increasing compressive force leading to decrease in the permissible surface speeds [34]. The speed limit is set by the temperature rise of the bearing and for this reason, different types of motion have different surface speeds [34]. This characteristic makes metallic plain bearings a superior option for high-speed applications, as they can withstand higher pressure-velocity levels without structural degradation compared to plastic plain bearings [4].

When comparing the thermal behaviour of plastic plain bearings to traditional metallic bearing, they differ in terms of heat dissipation and expansion. Metallic materials like bronze and steel have high thermal conductivity, which allows them to efficiently dissipate frictional heat. Plastics act as a thermal insulator, allowing heat to accumulate at the contact surface [35]. This limitation makes plastics more suitable for lower speeds, while metallic bearings can operate at higher speeds.

Another critical distinction is the reaction to thermal expansion. Metals have a relatively low and linear expansion rate, allowing for tight tolerances and minimal clearances that remain stable even during thermal fluctuation [35]. Plastic plain bearings have an expansion rate 10 to 20 times higher than steel, and their expansion rate is nonlinear [35]. As a result, polymer systems require larger initial clearances to prevent shaft seizure as frictional heat makes the temperature rise [35].

The choice of bearing and the shaft is a strategic design. Plastic plain bearings function as sacrificial components, designed to be softer than the steel shafts they support [9]. This ensures that wear is localized to the inexpensive and easily replaceable bearing rather than the costly structural components. Although this requires accepting lower speed and temperature limits compared to metallic plain bearings, the trade-off yields improvements in corrosion resistance, contamination tolerance, and a reduction in total life cycle costs for the component. While high-performance plastic bearings typically have lower acquisition costs than metallic bearings, their primary value lies in their ability to extend the overall service life of the machinery.

6 Conclusions

The research conducted in this thesis shows that strategic material selection is an essential factor in improving the reliability and efficiency of agricultural machinery in challenging environments. Modern agricultural machinery requires components that can withstand contamination, heavy shock loads and have regular maintenance schedules.

While traditional lubricated metal plain bearings have long been the industry standard, the transition to high-performance polymer plain bearings offers a revolutionary solution to the ongoing problems of abrasive wear and lubrication failures. The research shows that polymer-based plain bearings are often technically superior in certain agricultural applications because they achieve a maintenance-free, self-lubricating state through a fibers-reinforced thermoplastic matrix and integrated solid lubricants.

Unlike metallic plain bearings, which use external lubrication and often attract impurities that form an abrasive paste, polymer-based plain bearings operate dry and therefore prevent dirt from adhering and protect the shaft from accelerated wear. Igus® GmbH offers high-performance polymer bearings such as the Iglidur®-series, that provides load-carrying capacities comparable to traditional metallic bearings while offering excellent vibration dampening and edge load resistance. In addition, plastic plain bearings act as sacrificial components, allocating wear to the easily replaceable bearing instead of expensive structural components.

The use of plastic plain bearings also offers measurable improvements in operating economy and environmental sustainability. Case studies of intensive farming machinery and fertilizer spreaders show that eliminating manual lubrication can significantly save maintenance time, which translates into prominent reductions in personnel costs and productivity gains on an industrial scale. From an environmental perspective, eliminating the need for external lubrication prevents the pollution of soil, as even small amounts of leaked oil can contaminate huge amounts of water. In

addition, the production of plastic plain bearings requires less energy than steel, and modern recycling systems ensure a more sustainable product life cycle.

Despite these advantages, there are clear physical limits where metallic plain bearings are still necessary due to the lower thermal conductivity and higher thermal expansion of high-performance polymer bearings. These properties make plastics less suitable for high-speed applications where frictional heat buildup can lead to structural deterioration.

The collaboration with OEM Finland Oy and the utilization of Igus® GmbH technical solutions have been crucial in bridging the gap between theoretical materials science and practical agricultural technology. For OEM Finland Oy, the findings confirm that the promotion of tribologically optimized polymers can provide added value benefits for customers by reducing total operating costs and increasing machine uptime. The technical data, online configurators and design guides provided by Igus® enable accurate planning which reduces the risk of unplanned failures in the field.

In the future, the shift to autonomous agricultural machinery and precision farming is likely to further increase the demand for maintenance-free components. Future research should focus on the long-term performance of PTFE-free materials to further minimize the environmental footprint of polymer bearings. In conclusion, for the slow and loaded pivot points typical of agricultural machinery, high-performance polymer bearings represent a choice that meets the research objectives by mitigating environmental challenges and reducing total operating costs. The findings of this study demonstrate that modern engineering plastics can meet or exceed the performance of traditional materials. Bridging the gap between empirical material capabilities and customer perceptions is essential for promoting more efficient and sustainable engineering solutions.

References

- [1] “GGB Plain Bearings and Coatings for Off-Highway Applications”, Accessed: Mar. 24, 2026. [Online]. Available: <https://www.ggbearings.com/sites/default/files/2024-10/GGB-Plain-Bearings-and-Coatings-for-Off-Highway-Applications.pdf>
- [2] T. Barnes *et al.*, “The Utilization of Composite Bearings in Heavy Agricultural, Construction, Forestry, and Mining Equipment Design Applications,” in *Composite Materials - Science and Engineering*, IntechOpen, 2024. doi: 10.5772/intechopen.1004436.
- [3] “The Unsung Heroes of Harvest: Why Self-Lubricating Bearings are Revolutionizing Agriculture,” JIAXING VIPLUS INTERNATIONAL CO.,LTD. Accessed: Mar. 23, 2026. [Online]. Available: <https://www.bronzegleitlager.com/cases/the-unsung-heroes-of-harvest-why-self-lubricating-bearings-are-revolutionizing-agriculture-670.html>
- [4] “Plain bearings demystified- a complete guide for everyone | Transfer Multisort Elektronik,” TME. Accessed: Feb. 03, 2026. [Online]. Available: <https://www.tme.eu/en/news/library-articles/page/70526/plain-bearings-without-secrets-a-complete-guide-for-everyone/>
- [5] N. Bendaoud and M. Kadda, *The Tribological and Structural Behavior of Untextured and Textured Plain Bearings*. Newcastle-upon-Tyne, UNITED KINGDOM: Cambridge Scholars Publishing, 2023. Accessed: Feb. 10, 2026. [Online]. Available: <http://ebookcentral.proquest.com/lib/kutu/detail.action?docID=7187703>. Chapter 2, Pages 42-63.
- [6] “Plastic plain bearings in tractors and agricultural machinery.” Accessed: May 05, 2026. [Online]. Available: <https://www.igus.com/industries/industries-tractor-com>
- [7] “Bearing technology and energy chains for agricultural machinery | igus®.” Accessed: May 05, 2026. [Online]. Available: <https://www.igus.fi/industry/agricultural-engineering>
- [8] “Plain Bearing Explained - saVree.” Accessed: May 05, 2026. [Online]. Available: <https://savree.com/en/encyclopedia/plain-bearing>
- [9] “iglide® plain bearings - Design Guide,” igus® Engineer’s Toolbox. Accessed: Mar. 24, 2026. [Online]. Available: <https://toolbox.igus.com/design-guides/iglide-plain-bearings-design-guide/>
- [10] B. Bhushan, *Introduction to Tribology*. Newark, UNITED KINGDOM: John Wiley & Sons, Incorporated, 2013. Accessed: Feb. 03, 2026. [Online]. Available: <http://ebookcentral.proquest.com/lib/kutu/detail.action?docID=1120903>. Chapter 1 Pages 22-27.
- [11] “Tribology Explained | Machinery Lubrication.” Accessed: Mar. 25, 2026. [Online]. Available: <https://www.machinerylubrication.com/tribology-31340>
- [12] “07_plastic_friction_bearings.pdf.” Accessed: Mar. 26, 2026. [Online]. Available: https://www.aikolon.fi/site/assets/files/5096/07_plastic_friction_bearings.pdf
- [13] “IGL_CAT_igus_Whitepaper-bearing_points_without_lubrication_EN_1.pdf.” Accessed: Mar. 19, 2026. [Online]. Available: https://igus.widen.net/s/mxqsjxxprc/igl_cat_igus_whitepaper-bearing_points_without_lubrication_en_1?utm_medium=email&utm_source=sfmc&utm_campaign=MA00003969&utm_content=MA00003969&utm_term=&externalKey=b90a4314b4a58a11d43b8bec8fda68497af337c43d2ce0f0607a4eaaf385b32f&brand=transactional

- [14] “Plain bearings – advantages and disadvantages at a glance - igus Blog.” Accessed: Feb. 17, 2026. [Online]. Available: <https://blog.igus.eu/plain-bearings-advantages-and-disadvantages-at-a-glance/>
- [15] “IGL_DS_igus_whitepaper-iglidur_vs_conventional_materials_EN_1.pdf.” Accessed: Mar. 06, 2026. [Online]. Available: https://igus.widen.net/s/mzxhqhpdh/igl_ds_igus_whitepaper-iglidur_vs_conventional_materials_en_1?utm_medium=email&utm_source=sfmc&utm_campaign=MA00000640&utm_content=MA00000640&utm_term=&externalKey=b90a4314b4a58a11d43b8bec8fda68497af337c43d2ce0f0607a4eaaf385b32f&brand=transactional
- [16] “IGUS_GEN_EN_brochure_igutex_image_MAT0075556.20_KS__EN_1.pdf.” Accessed: Mar. 23, 2026. [Online]. Available: https://igus.widen.net/view/pdf/zrx6tukhsr/IGUS_GEN_EN_brochure_igutex_image_MAT0075556.20_KS__EN_1.pdf?t.download=true&u=gqh1pb&utm_medium=email&utm_source=sfmc&utm_campaign=MA00002483&utm_content=MA00002483&utm_term=&externalKey=b90a4314b4a58a11d43b8bec8fda68497af337c43d2ce0f0607a4eaaf385b32f&brand=transactional
- [17] “Technical plastics vs. high-performance plastics vs. plastics for movement - igus Blog.” Accessed: Mar. 26, 2026. [Online]. Available: <https://blog.igus.eu/technical-plastics-vs-high-performance-plastics-vs-plastics-for-movement/>
- [18] D. Deshwal, S. U. Belgamwar, S. I. Bekinal, and M. Doddamani, “Role of reinforcement on the tribological properties of polytetrafluoroethylene composites: A comprehensive review,” *Polym. Compos.*, vol. 45, no. 16, pp. 14475–14497, 2024, doi: 10.1002/pc.28802.
- [19] B. Mishra, D. Varshney, and M. Gupta, “Effect of Fillers on the Performance of Fibre Reinforced Polymer Hybrid Composites: A Comprehensive Review,” *Polym.-Plast. Technol. Mater.*, vol. 64, Jun. 2025, doi: 10.1080/25740881.2025.2519024.
- [20] “How to select the right bearing lubricant | GlobalSpec.” Accessed: Apr. 07, 2026. [Online]. Available: <https://insights.globalspec.com/article/10116/how-to-select-the-right-bearing-lubricant>
- [21] “IGUS_GEN_EN_brochure_igutex_image_MAT0075556.20_KS__EN_1.pdf.” Accessed: Apr. 15, 2026. [Online]. Available: https://igus.widen.net/view/pdf/zrx6tukhsr/IGUS_GEN_EN_brochure_igutex_image_MAT0075556.20_KS__EN_1.pdf?t.download=true&u=gqh1pb&utm_medium=email&utm_source=sfmc&utm_campaign=MA00002483&utm_content=MA00002483&utm_term=&externalKey=b90a4314b4a58a11d43b8bec8fda68497af337c43d2ce0f0607a4eaaf385b32f&brand=transactional
- [22] S. Uwe, “Iigus solutions for agricultural engineering.” [Online]. Available: www.igus.eu/agriculture
- [23] “Plain bearings for agricultural engineering.” Accessed: May 06, 2026. [Online]. Available: <https://www.igus.fi/industry/agricultural-engineering/plain-bearings-for-agricultural-technology>
- [24] “What does the pv value signify? - igus Blog.” Accessed: May 07, 2026. [Online]. Available: <https://blog.igus.eu/knowledge-base/what-does-the-pv-value-signify/>

- [25] “COB095.” Accessed: May 07, 2026. [Online]. Available: https://www.internordic.com/produkter/lager/glidlager/glidlager---brons-_-C29952/cob095-_-P2020302
- [26] “SHB® Case Hardened Steel Bearings & Bushings | GGB.” Accessed: May 07, 2026. [Online]. Available: <https://www.ggbearings.com/en/our-products/metal-and-bimetal-bearings/ggb-shb>
- [27] “Robust plain bearings for heavy-duty use in cultivators | igus®.” Accessed: Apr. 23, 2026. [Online]. Available: <https://www.igus.eu/industry/agricultural-engineering/applications/plain-bearings-for-cultivators-and-harrows>
- [28] “Plain bearings extend service life in yard loaders | igus®.” Accessed: Apr. 23, 2026. [Online]. Available: <https://www.igus.eu/industry/agricultural-engineering/applications/plain-bearings-for-court-loaders>
- [29] “Coulter with iglidur plain bearings | 2023 manus.” Accessed: Apr. 23, 2026. [Online]. Available: <https://www.igus.eu/industry/agricultural-engineering/applications/plain-bearing-for-coulter>
- [30] K. Friedrich, “Polymer composites for tribological applications,” *Adv. Ind. Eng. Polym. Res.*, vol. 1, no. 1, pp. 3–39, Oct. 2018, doi: 10.1016/j.aiepr.2018.05.001.
- [31] “IGL_CAT_WBA_Werkzeugbauakademie_-_Study_results_-_Ecological_assessment_of_the_use_of_plastic_plain_bearings_EN_1.pdf.” Accessed: Apr. 24, 2026. [Online]. Available: https://igus.widen.net/view/pdf/ioahdqip7g/IGL_CAT_WBA_Werkzeugbauakademie_-_Study_results_-_Ecological_assessment_of_the_use_of_plastic_plain_bearings_EN_1.pdf
- [32] “15-The-True-Cost-of-Bearing-Lubrication-White-Paper-CA.pdf.” Accessed: Apr. 27, 2026. [Online]. Available: <https://blog.igus.ca/wp-content/uploads/2023/04/15-The-True-Cost-of-Bearing-Lubrication-White-Paper-CA.pdf>
- [33] “Recycling, plastics recycling and further recycling measures at igus.” Accessed: Apr. 28, 2026. [Online]. Available: <https://www.igus.fi/company/sustainability/recycling>
- [34] “igidur plain bearing - surface speed.” Accessed: Apr. 29, 2026. [Online]. Available: <https://www.igus.eu/plain-bearing/wiki/surface-speed>
- [35] “igidur plain bearings - Temperatures.” Accessed: May 07, 2026. [Online]. Available: <https://www.igus.co.uk/plain-bearing/wiki/temperatures>