

Perspective

Toward an integrated understanding of how extreme polar light regimes, hybridization, and light-sensitive microbes shape global biodiversity

Kari Saikkonen,^{1,*} Traci Birge,^{1,2} Benjamin Fuchs,¹ Marjo Helander,³ Janne A. Ihalainen,⁴ Riitta Nissinen,³ and Pere Puigbò^{3,5,6}

¹Biodiversity Unit, University of Turku, 20014 Turku, Finland

²Ruralia Institute, University of Helsinki, 50100 Mikkeli, Finland

³Department of Biology, University of Turku, 20014 Turku, Finland

⁴Nanoscience Center, Department of Biological and Environmental Science, University of Jyväskylä, 40014 Jyväskylä, Finland

⁵Department of Biochemistry and Biotechnology, Rovira i Virgili University, 43007 Tarragona, Catalonia, Spain

⁶Nutrition and Health Unit, Eurecat Technology Center of Catalonia, 43204 Reus, Catalonia, Spain

*Correspondence: karisaik@utu.fi

<https://doi.org/10.1016/j.oneear.2024.08.002>

SUMMARY

Low knowledge sharing across disciplines studying geo-evolutionary processes determining species adaptations hinders the mitigation of biodiversity loss driven by human-induced climate warming. Further, the impacts of microbes and light regimes on species adaptations to accelerated climate warming are largely ignored. On a geologic timescale, range shifts to higher latitudes necessitate adaptation to new light environments, including extreme polar seasons, i.e., "polar night." Chemical crosstalk among coevolving microbes and plants modulates ecologically relevant traits, and photosensitive and other microbes may aid plant adaptation. We hypothesize that hybridization in new "circumpolar hybrid zones" and plant-microbial cooperation in those zones and elsewhere will be significant in maintaining genetic admixture and species diversity on a geological timescale. We propose the concept of circumpolar hybrid zones and an integrated framework, inclusive of microbes, to unite disparate research disciplines, advance understanding of evolution, and improve strategies for climate adaptation and mitigation.

OVERARCHING APPROACH TO UNDERSTAND THE RESILIENCE OF GLOBAL BIODIVERSITY

We call for bringing together multiple evolutionary key processes to explain the capacity of biodiversity to persist across geological timescales and under the pressure of unprecedented climate change. These key processes include climate-change-driven species' range shifts, microbe-assisted plant adaptations based on light sensitivity, photochemistry and induced responses, and hybridization. While these processes are thoroughly studied, and their relevance to adaptive evolution is widely accepted and reviewed in the literature, the individual processes are currently siloed into separate disciplines with limited knowledge sharing. The current knowledge from these disparate fields varies from separate field observations and qualitative data to advanced methods-oriented studies on mechanism descriptions. As a result, the causalities determining ecosystem functions, dynamics, and evolution cannot be readily elucidated by the available datasets, which are largely incompatible for overarching approaches. To elevate our understanding of climate-change-driven species range shifts and the evolution of novel species assemblages over geological timescales, we integrate these branches into a holistic framework and suggest a guide and tools for future research.

We hypothesize that hybridization and microbes play a significant role in maintaining and promoting global biodiversity on a geological timescale. First, resilience, maintenance, and regeneration of global biodiversity largely depend on the dispersal ability of compatible organisms with sufficient genetic variation required to both cope with changing selection pressures and diversify. Second, the importance of hybridization to adaptive evolution and radiation is widely recognized.^{1–3} Hybridization can increase the genetic variation in lineages and facilitate rapid speciation and adaptive radiation, especially if it involves ancestral variation derived from hybridization.^{1,4–10} Third, myriad microbes, plants, and animals have been shown to be capable of moving into new areas worldwide.^{11–13} However, the existence and role of hybridization in higher latitudes and consequent hybrid speciation in maintaining the genetic admixture to support adaptive radiation and biological diversity on a geological timescale has been ignored.¹⁴ Here, we launch the term "circumpolar hybrid zone" into the lexicon (Figure 1A) and propose, for the first time, the theoretical framework that the polar light environment creates and promotes circumpolar hybrid zones, which, together with recurrent cross-latitude migration of species, play an important role in maintaining global biodiversity on the geological timescale (Figures 1B and 1C).



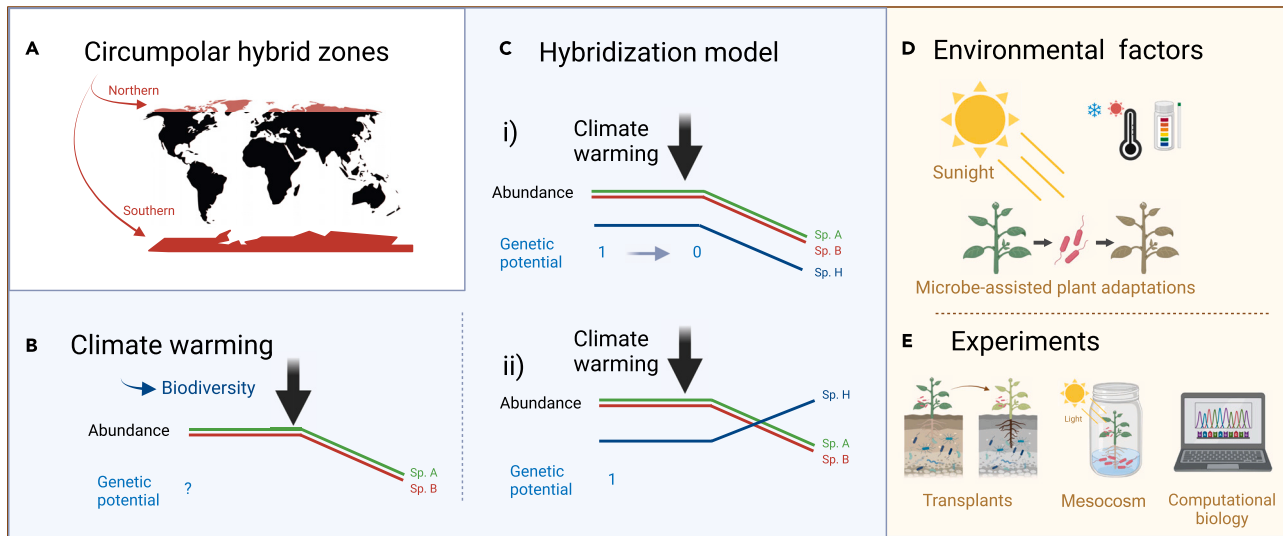

Figure 1. Perspective overview

(A) Circumpolar hybrid zones. Climate change will drastically affect biodiversity at genetic, species, and habitat levels. However, introgressive hybridization is likely to play a significant role in maintaining genetic admixture and species diversity. Moreover, circumpolar (northern and southern polar regions) hybrid zones are likely to play significant roles in maintaining the genetic potential.

(B) Climate warming and effect on biodiversity. The impact of climate warming is unevenly distributed across latitudes, and it is especially prone in the circumpolar regions. The effect of climate warming may be evident by measuring species decline (e.g., species A and B). However, with no further information, the evidence would reveal an imminent extinction process of both species due to climate warming.

(C) Use of the hybridization model. We argue that tackling climate-change-driven biodiversity loss requires that we urgently develop a thorough understanding of the elements of biological diversity beyond the species level and ensure that sufficient genetic potential will remain to support the associated ecosystem functions and services on Earth in the future. A hybridization cross-latitudinal model allows a gene-centric quantification of the effect of climate change at species, genetic, and habitat levels. The genetic potential of a hybrid either decreases (i) or increases (ii) depending on the fitness of the hybrid due to climate.

(D) Environmental factors. Several environmental factors, e.g., photoperiodism, temperature, and soil quality (e.g., pH), are likely to play a major role in the generation of hybrids. We argue that microbe-assisted plant adaptations, especially those involved in light responses and photoperiodism, are likely to play a major role in enhancing global biodiversity.

(E) Further experiments. Interdisciplinary research approaches that involve transplant experiments, mesocosm studies, and computational biology methods are required to test the hypothesis that genetic light sensitivity, photochemistry, and induced responses facilitate microbial-mediated plant adaptations to seasonally differentiated light environments and that the seasonality of day length promotes the maintenance of circumpolar hybrid zones at higher latitudes, thereby playing an important role in maintaining biodiversity globally.

The key terms are explained in [Box 1](#).

POLAR ECOSYSTEMS ARE AT THE HIGHEST RISK

Climate-change-driven loss of diversity at the genetic, species, and habitat levels represents the greatest global challenge facing the world today. With the Arctic warming nearly four times as fast as other regions, polar ecosystems are at particular risk.^{15–18} However, our understanding of how fundamental global boundary conditions, functional organismal diversity, and causalities determine the consequences of climate warming on terrestrial biodiversity in polar regions is still in its infancy. We do know that climate warming promotes species' range shifts across latitudes and that moving poleward has geographical limits. Thus, climate change causes an “escalator to extinction” because cool-adapted species shift their ranges to the poles, only to be extirpated if conditions are unsuitable for survival.¹⁹ The outcomes, however, vary in different areas of the polar regions.

Climate warming will drastically alter the landscapes of the northern and southern polar regions. In the Northern hemisphere, the impact of climate warming is unevenly distributed across the Arctic circumpolar region. Due to the warming effects of the Gulf Stream ([Figure 2](#)), comparable climate zones are present at higher latitudes in Western Europe compared

with other parts of the Arctic, and cold-adapted Northern European species are expected to be the first Arctic species driven to move longitudinally to other colder Arctic regions of Eurasia and North America.²⁰ In the long term, the polar glaciers will disappear, and the Arctic Basin, which is a semi-enclosed ocean covered by floating sea ice, will become an open ocean. Although the predictions of global climate models vary, most suggest that the Arctic Ocean will be ice-free before the end of the century.^{21,22} In contrast, less than 2% of Antarctica—the world's fifth-largest continent—is ice-free, but this is estimated to increase by close to 25% by the end of the century.²³ Thus, climate warming will generate new ice-free areas on the Antarctic continent, which will be the last remaining large-scale habitats in the world suitable for terrestrial species adapted to extreme cold. Polar regions are, therefore, both sensitive habitats under pressure as well as final refuges for cold-adapted species moving to higher latitudes in response to global heating. As a result of unprecedented climate warming, evolutionary processes in the polar regions will reshape future biodiversity assemblages at the geological timescale. The study of these phenomena in the polar regions provides crucial insight into the mechanisms of adaptation, the understanding of which is essential to

Box 1. Glossary

Adaptive radiation: rapid speciation and phenotypic adaptation of new species with a common ancestor as response to new or changing environment.

Allopatric: species or populations occurring in separate, non-overlapping geographic areas.

Allopolyploidy: evolutionary process whereby an additional set of chromosomes is derived from another species. Allopolyploidy is commonly detected in many groups of plants.

Conjugation: the transfer of genetic material between bacterial cells.

Holobiont: the assemblage of different species forming a coevolving ecological unit, usually a eukaryotic host (e.g., plant) and its associated endo- and extracellular microbes.

Horizontal gene transfer (HGT): exchange of genetic material between organisms without mating.

Hybridization: in biology, hybridization means the sexual crossing between two genetically distant organisms. Hybridization can occur within (intraspecific hybridization) or between species (interspecific hybridization).

Hybrid speciation: the origin of a new species through hybridization between distinct species.

Hybrid zones: the geographic regions where genetically divergent populations, varieties, subspecies, or species meet and interbreed.

Introgression: transfer of genetic information from one species into the gene pool of another as a result of hybridization and repeated backcrossing.

Microbial rhodopsins: membrane-embedded proteins that provide light-dependent ion transport in microbes.

Niche: the position a species occupies within an ecosystem as defined by the range of abiotic and biotic resources and conditions required for persistence of the species.

Parapatric speciation: speciation in contiguous but spatially segregated environments where subpopulations evolve in reproductive isolation and eventually become reproductively incompatible with each other.

Phenology: the timing of recurrent life cycle events of organisms, e.g., time to grow, reproduce, migrate, and become dormant.

Photoperiodism: responses of organisms to the relative length of the day and the night.

Phytochromes: a group of pigments capable of absorbing red- and far-red light from the visible light spectrum.

Primary producers (/autotrophs): green plants and microorganisms that are capable of converting the energy in light (photoautotrophs) and/or inorganic material sources (chemoautotrophs) into organic substances.

Proteorhodopsin (PR): photoactive retinal-binding membrane proteins.

mitigating global biodiversity loss associated with climate change.

LINKING PHOTOPERIODISM, PHENOLOGY OF REPRODUCTION, AND HYBRID ZONES TO ADAPTIVE RADIATION

Hybrid zones have played a significant role in the evolutionary trajectories of all major groups of plants and animals.^{1,4,7,8,10,24–27} Taxonomic surveys and genomic data suggest that although hybridization can arise, for example, as a consequence of human actions, hybrid zones are commonly attributable to changes in species geographic ranges due to Earth's paleoclimatic periods and/or the physiographic features of Earth, such as chains of mountains and islands.^{24,26,28} Consequently, hybrid zones can persist for hundreds or thousands of years, during which gene flow may occur between both interbreeding species and genetically divergent intraspecific lineages and, thereby, facilitate introgression, hybrid speciation, allopolyploidy, and adaptive radiation of new species.^{1,6,25,29} However, hybrid zones and hybrid species are dynamic in space and time due to both natural and human-assisted environmental changes and novel species invasions.^{3,8,9,24,26} Thus, the detected adaptive radiation and global biodiversity can be explained by the forces driving species range shifts, which can lead to repeated hybridization, rapid reproductive isolation from the same ancestral population without physical isolation, and reticulated evolution.¹

Anthropogenic climate change has been recognized as among the most important contemporary forces driving species range distributions^{3,20,30–32} and, consequently, facilitating reproductive isolation during parapatric speciation and novel encounters between previously allopatric taxa.^{33,34} Because anthropogenic climate warming in the Arctic and Antarctic is substantially faster than the global average,^{15–17} it is expected that the reshuffling of species assemblages and interspecific interactions—potentially leading to adaptive hybrid speciation—will be unprecedentedly strong at higher latitudes.³⁵ Observational evidence from the Northern hemisphere, where hybrids and hybrid speciation have mainly been studied, supports this hypothesis. Hybrids are commonly detected at higher latitudes in aquatic and terrestrial environments in both plants and animals.^{9,11,21,26,36–40} For example, natural hybrids of herbaceous and woody plants appear to be particularly common in the Arctic and sub-Arctic regions.^{11,41} To date, the high prevalence of hybridization at higher latitudes has commonly been explained by alternating glacial and interglacial periods during the Quaternary period that led to contractions and expansions in species distributions.^{26,42} The resultant recurrent isolation and contact of species propelled the divergence of intraspecific lineages.^{26,42} In accordance with this, increasing evidence suggests that climate-change-driven poleward shifts in species ranges potentially result in novel hybrid zones, especially at higher latitudes.^{32,34,43} Similarly, the decisive role of hybrids as reservoirs of genetic diversity and a storehouse of cold-tolerant genes in species threatened by climate change has been recognized.^{10,14}

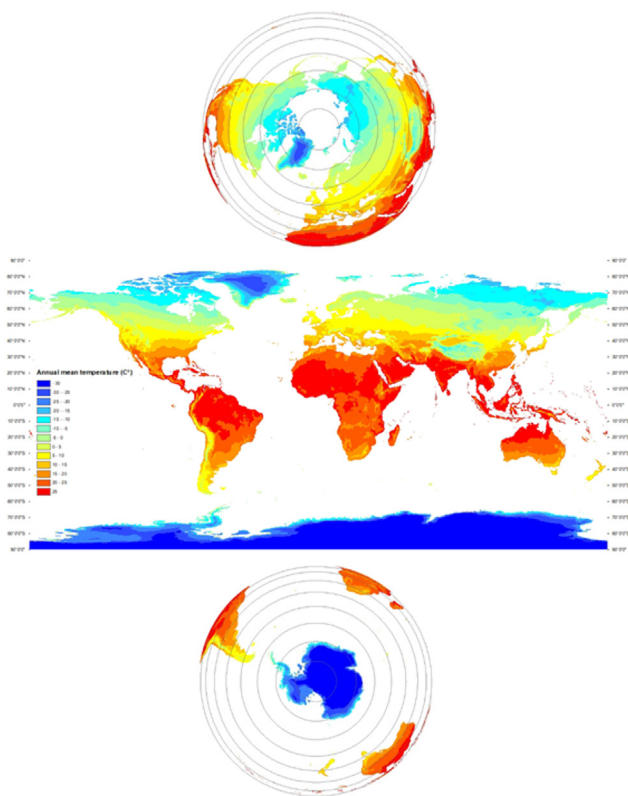

Figure 2. World climate map illustrating that the distributions of land and sea in the polar regions are the inverse of each other, and similar climate zones are present at higher latitudes in Western Europe compared to the latitudinal distribution of those zones in North America and Eurasia

Data taken from the WorldClim Database (<http://www.worldclim.org/>).

In contrast, here we incorporate entirely overlooked organismal adaptations to day length, light intensity, and spectral composition in this context.

Given that phenology is crucial for individual fitness, particularly in strongly seasonal environments, we emphasize the role of a poleward increase of seasonal fluctuation in day length as an accurate and consistent abiotic environmental force used by many organisms to coordinate their phenological events (Figure 3A).^{20,44–47} Compared to more variable seasonal cues, seasonality in light intensity, duration, and spectral composition are stable abiotic environmental factors that do not change with local or global climatic conditions, as these changes are governed by the tilt of the Earth’s axis and elliptical orbit around the Sun.⁴⁴ Globally, this seasonality in day length determines the availability of solar energy for primary producers as well as the ecosystems depending on them at both ecological and evolutionary timescales.^{20,44} Although a changing climate may relax or strengthen temperature barriers and allow organismal range shifts, the organisms must cope with light-driven seasonality in primary production in addition to multiple novel stress factors. This is particularly pronounced in polar ecosystems within the Arctic and Antarctic circles, which are characterized by extremes ranging from the polar day in summer to the polar night in winter. The optimal timing of reproduction is particularly

important for organismal fitness in these extreme environments, where the time window for successful reproduction and offspring survival is most limited due to the seasonality of solar energy (Figure 3A).

We hypothesize that stabilizing selection by a combination of seasonal variation of day length and a short growing season should narrow the variance in reproductive timing in populations and increase the synchrony of reproductive phenology among populations, especially at higher latitudes (Figure 3B). This causes overlap in the timing of reproduction among genetically distinct populations, phenotypically distinguishable or plastic groups defined as subspecies or varieties belonging to a species complex, and species that are otherwise compatible (Figure 3C).¹¹ We acknowledge that several pre- or postzygotic reproductive barriers, such as temporal, behavioral, mechanical, or gametic mismatch, as well as low viability and the sterility of hybrids, may restrain interbreeding.² While acknowledging the complexity of these reproductive barriers, we concentrate on spatially overlapping distributions and synchronous reproduction of organisms because they are the primary prerequisites for hybridization and hybrid zones.

As a global and stable abiotic ecological filter, a poleward increase in the seasonality of day length may create, promote, and maintain multispecies hybrid zones at higher latitudes. Under a changing climate, synchronous reproductive timing requires the ability of both native and invading species to respond and adapt to new temperatures and light environments. In general, life history traits can evolve in response to changing selection pressures if there is sufficient genetic variability or phenotypic plasticity. The relative importance of phenological events for different life forms depends largely on the life history strategies of the organisms; for example, the timing of reproduction is crucial for sexually reproducing and short-lived organisms such as annual plants.²⁰ An increasing number of observational and experimental studies have demonstrated that native and invading wild and domesticated species are able to successfully synchronize their biological events with changing temperatures or new light environments.^{44,46,48,49} Thus, we expect that climate-change-driven range shifts leading to the spatial overlap of genetically divergent populations, varieties, subspecies, or species create opportunities for gene flow and introgressive hybridization between them due to light-environment-driven convergence of reproduction timing.

Introgressive hybridization can facilitate speciation and adaptive radiation in several ways. For example, introgressive hybridization can (1) facilitate gene flow across the hybrid zone, (2) increase genetic variation and alter the genetic correlations among traits, (3) reshuffle DNA into new combinations and thereby facilitate the operation of genetic material in novel cellular and ontogenetic contexts, and (4) alter ecologically important phenotypic traits.^{1,4} We argue that future studies should take hybrids into account as “poorly differentiated waystations in a continuous hierarchy of biodiversity”⁶ and aim to capture the breadth of relevant genetic diversity, structure, and dynamic features of the mosaics of genotype frequencies in populations and supposed species and species complexes rather than focusing only on species diversity. To this end, hybridization challenges the biological species concept. However, if we accept recurrent hybridization and consequent introgression as a process increasing genetic

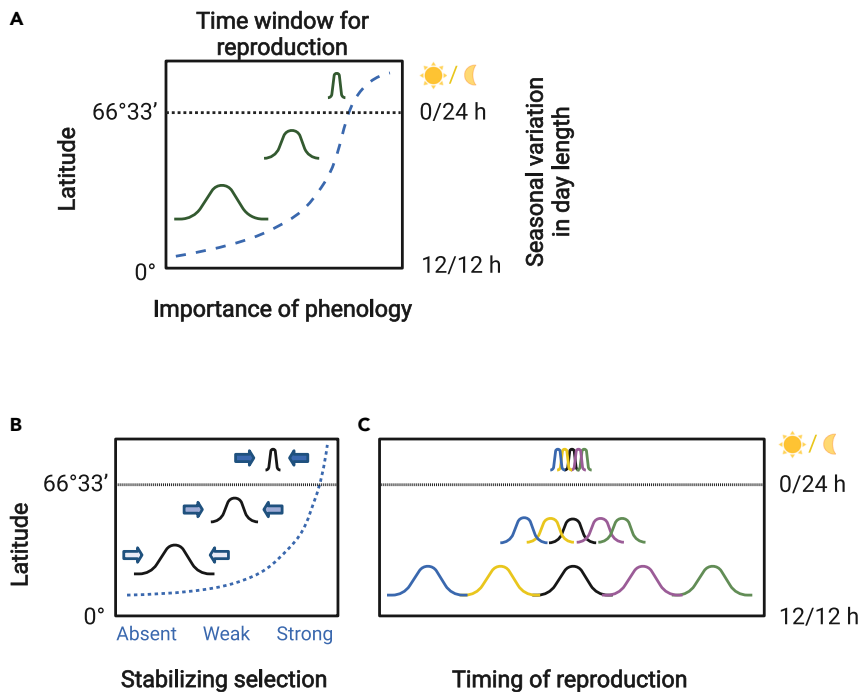

Figure 3. The timing of reproduction across latitudes

Effects of latitude-based seasonal variation of day length on phenology and the time window for successful reproduction (A) and latitude-driven stabilizing selection on light-dependent traits (B) and the timing of reproduction (C). The different colors in (C) indicate genetically distinct populations or species.

variation during speciation, then we can expect that the promotion of hybrid zones by poleward increases in the seasonality of day length will result in phylogenetic nets with genotypic clusters rather than classic bifurcating trees comprising clearly distinct species (Figures 4A and 4B).

EVIDENCE OF HYBRIDIZATION AT HIGHER LATITUDES

In concordance with our hypothesis of circumpolar hybrid zones, hybrids are commonly found in many sub-Arctic and Arctic plants.^{11,41,50,51} Many of these plants are trees, suggesting that introgressive hybridization provides the genetic variation necessary to adapt to harsh environmental conditions, particularly in perennial species with a long life expectancy and high age at maturity. For example, hybridization has played an important role in the evolution of forest trees.^{41,51} In addition, photoperiodic adaptation and adaptability to new light environments require that the species' photoperiodic life history traits are heritable.⁴⁵ Thus, predicting species' range shifts across latitudes and their probability of hybridizing with other compatible lineages and/or species requires an understanding of the relative importance of phenotypic plasticity and the genetic regulation of the traits determining their timing of reproduction. This further includes a need to understand the genetic mechanisms that may promote or constrain the adaptive evolution of the species and their hybrids. The eco-evolutionary consequences can be strikingly different, depending on whether the timing of reproduction is phenotypically plastic, genetically determined, and/or epigenetically modulated, even if the populations appear to be similarly adapted to the environment. This is because phenotypically plastic individuals with low genetic variation may perform similarly to individuals reproducing at the optimal time in a population with sufficient genetic variability.

As hybridization can occur when two or more species overlap geographically and display hierarchical spatial metapopulation structure with local populations connected by dispersal,⁵² hybrid zones can simultaneously develop among newly interconnected populations as well as multiple species.^{5,53,54} We propose that such latitude-related hybridization can have great but largely ignored repercussions even in ecological time, and these repercussions should be taken into account in further explorations of biodiversity and how it responds to a changing climate (Figure 4C).

Hybridization may play an equally important role at other trophic levels at higher latitudes as well. In addition to plants, many invertebrates and vertebrates display photoperiodic adaptations,⁴⁵ and hybrids are commonly detected in many animal taxa at higher latitudes in both aquatic and terrestrial environments.^{21,36,55–60} For example, natural hybrids of several invertebrate taxa,²⁶ fish,^{56,60} and other vertebrates, including rodents, weasels, ungulates, bears, and whales,^{21,26,37} appear to be common in Arctic and sub-Arctic regions. Presumably, such adaptive responses to seasonal light environments are likely to evolve if the fitness of the species is highly dependent on other species adapted to photoperiodic cues²⁰ and reinforced by hybridization-driven trophic cascades.

SHIFTING FROM A SPECIES- TO A HOLOBIONT-ORIENTED APPROACH

The majority of previous ecological studies on the effects of climate change on biodiversity at higher latitudes concentrate on the importance of the temperature window for species' range. Albeit acknowledging this inevitable important factor (in addition to the low level of nutrients), we wish to turn our attention to plant-associated microbes and how they could facilitate adaptive radiation of plants into polar regions (Figure 1D). As polar regions warm, newly ice-free terrestrial areas will be, however, first available to pioneering microorganisms from sub- and supraglacial sediments and organisms shifting their ranges poleward.^{61–63} Here, we propose that the great adaptive capacity of microbes plays a significant role in ecological succession in polar areas characterized by extreme seasonality of solar radiation. Recent advances in molecular microbiology have revolutionized our understanding of the diversity and functions of microbial organisms. Today, we know that microbes are ubiquitous and essential associates of virtually all higher organisms.^{64–66} Similarly, microbes are found in nearly all plants and known to play a fundamental role in

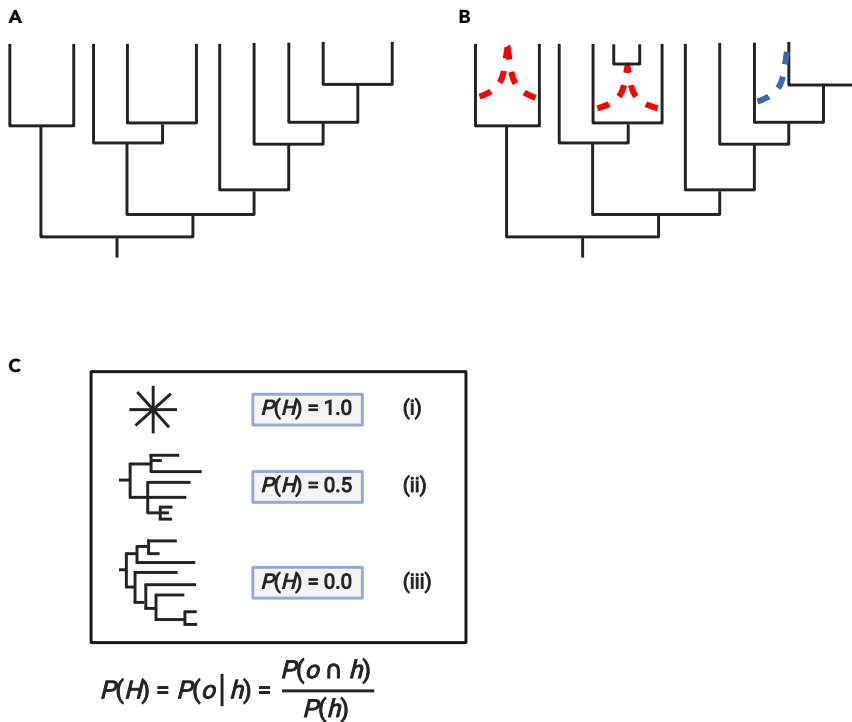

Figure 4. Phylogenetic scenarios

Bifurcating phylogenetic tree (A) and phylogenetic network with genotypic clusters (B). Hybrid speciation and introgression between lineages are indicated in red and blue, respectively. Hypothetical phylogenetic scenarios of eight species to generate hybrids ($P(h) = 1$) at different latitudes in relation to their distribution overlap (C). (i) Star phylogeny ($P(o) = 1$) with the total spatial overlap in the Arctic. (ii) Unresolved phylogenetic tree ($P(o) = 0.5$) with a 50% spatial overlap at lower latitudes. (iii) Resolved phylogeny ($P(o) = 0$) with no spatial overlap at the Equator.

photosensory proteins^{72,73} and promote the maintenance of biodiversity at higher latitudes. To do this, we first explore the biophysical and genetic bases of light responses in bacteria and plants. Then, we suggest how the light environment affects their phenology, adaptive coevolution, and distribution.

Today, bacterial DNA constitutes approximately 30% of the total DNA in the biosphere.⁷⁴ Biogeographical distribution, abundance, and diversity of free-living bacteria appear to be primarily determined by niche differentiation rather

determining the fitness of their hosts. Microbes associated with their shared hosts comprise multipartite entities, holobionts, which are an extended phenotype and the target of phenotypic selection.^{67,68} Plant microbiomes are evolutionarily older than contemporary land plants themselves, and the majority of plant evolution has fundamentally incorporated coevolutionary processes of plant-microbe interactions.^{64,66,69,70} Plant microbiomes are crucial to plant nutrition acquisition, pest and pathogen resistance, tolerance to abiotic stress, and plant growth regulation.^{66,71} Microbes modulate plant growth and adaptation both directly by producing biocontrol or signaling compounds and indirectly via release or modification of phytohormones.^{68,71} Thus, plant microbiomes will likely be a major factor determining the direction and dynamics of the primary succession as polar regions are exposed to pioneer plants.

We next explore the bases of light responses in bacteria and plants and suggest how the light environment may affect their phenology, adaptive coevolution, and distribution. Then, we propose a conceptual framework for how photoperiodism in bacteria and plants based on light sensitivity, photoactive properties of biomolecules, and/or chemical signaling involved in microbe-plant holobionts may facilitate plant adaptations^{71–73} to promote the maintenance of biodiversity at higher latitudes. Finally, we propose avenues for how the framework can be approached by field and laboratory experiments, modern genomic tools, and computational biology (Figure 1E).

GLOBAL DISTRIBUTION OF FREE-LIVING AND PLANT-ASSOCIATED PHOTOACTIVE BACTERIA

We propose a conceptual framework for how bacteria may facilitate plant adaptations via universal and evolutionarily conserved

than limited by dispersal.^{75–77} In accordance with this, bacterial densities (10^7 – 10^{10} per gram soil) and species richness do not differ from those in temperate climates, while the community composition of polar soil microbiomes clusters apart from those in temperate regions.^{78,79} Likewise, endophytic bacteria from Arctic plants are taxonomically more closely related to bacteria from other cold climates, including Antarctica, than from geographically closer temperate climate plants,^{80,81} and endophytic fungi from Antarctica are phylogenetically close to subarctic moss-associated fungi.⁸² This relatedness strongly suggests the global presence of plant-associated microbiota endemic to cold climate ecosystems. The fitness of organisms in polar regions is challenged by both low temperatures and strong seasonality in day length in higher latitudes. Thus, we hypothesize that the light environments shape polar microbiota by selecting for photoactive bacteria capable of using day length to coordinate their phenology. In some cases, fungal seasonality is known to be mediated by photoperiodism and temperature,⁴⁴ and numerous marine and terrestrial microorganisms are known to be photosynthetic or phototactic or respond to light in other ways.^{73,76,83,84} Furthermore, recent evidence has revealed that photoactive bacteria are ubiquitous in sub-Arctic and Arctic plants.⁸⁵

Studies on photochemical responses have focused mainly on photoactive retinal proteins, for example microbial rhodopsins, which function in light-energy conversion and light-signal transduction.⁸⁶ Microbial rhodopsins, originally discovered in extremely halophilic (salt-saturated water) archaea, produce light-driven energy in photoheterotrophic bacteria, widely present in oceanic waters worldwide,⁸⁷ and may play a unique role in biogeochemical cycles.^{88,89} Importantly, in addition to proteorhodopsin (PR)-containing phototrophic (PRP) bacteria,

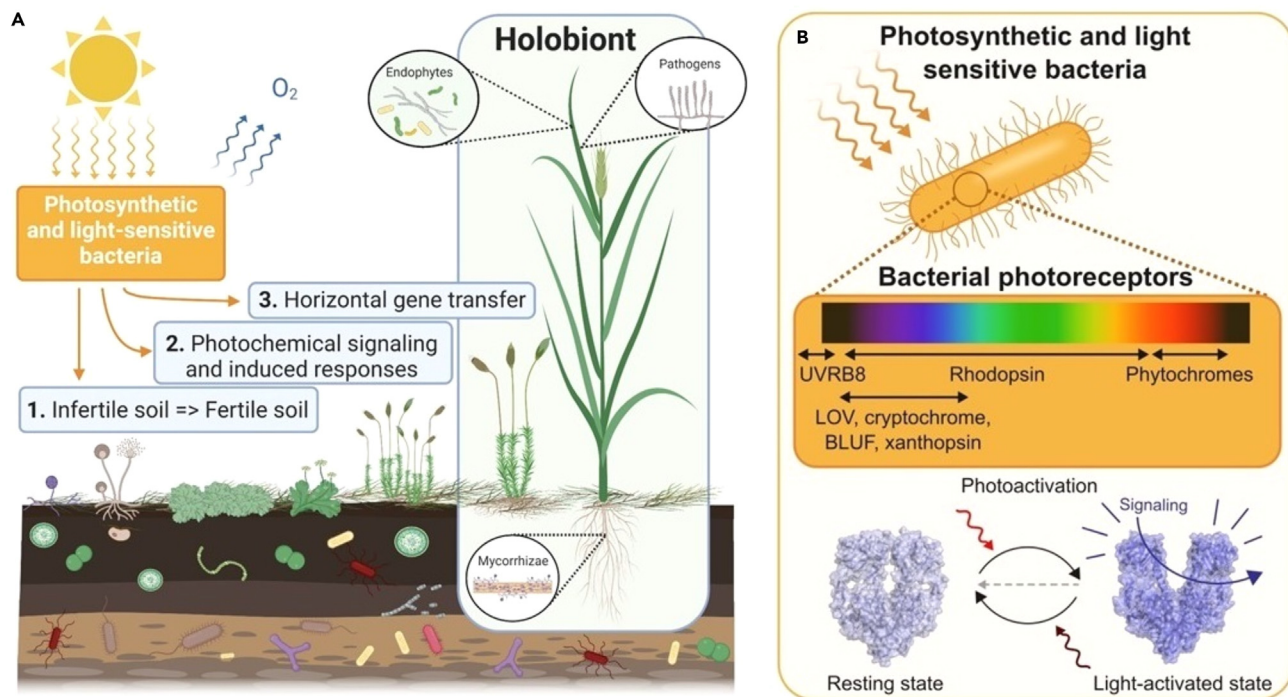

Figure 5. The role of photoactive bacteria in terrestrial polar ecosystems

Photoactive bacteria-mediated support to heterotrophic microbes and plants in terrestrial polar environments (A). The major photosensory proteins of microbes indicated with the wavelength range of their activity (B). The structures on the lower image relate to the action of the red photosensory protein, phytochrome.^{97,98}

photoheterotrophic microbes include also aerobic anoxygenic phototrophs (AAPs), which perform anoxygenic photosynthesis on or in their hosts.^{90,91} Remarkably, some phototrophs contain both phototrophic mechanisms, named thus dual phototrophs.⁹² We revealed that these dual phototrophs, mainly described from cold ecosystems, have wide photosensor protein compositions⁹³ that may facilitate advanced sensing of the light environment. Moreover, some species may use far-red light for oxygenic photosynthesis, mainly distributed across hypersaline lakes, corals, and Arctic and Antarctic regions.⁸⁴ This suggests that many photoactive protein complexes play a significant adaptative role, already recognized for aquatic prokaryotes^{83,90,92} but also increasingly reported for terrestrial plant-associated^{67,72,85,94} prokaryotes.

The presence of PRP genes in photoheterotrophic bacteria varies across latitudes⁹⁰ and supports our hypothesis that divergent microbial adaptations occur in response to different light environments across latitudes. Microbial rhodopsin genes tend to be evolutionarily conserved and widely detected across all three domains of life (Bacteria, Archaea, and Eukarya).⁸⁶ They are also found in some giant viruses, which may modulate light-dependent signals in infected hosts.⁹⁵ The question is whether the rapid adaptive evolution of microbes can facilitate plant adaptations to photoperiodism.

PLANT ADAPTATIONS MEDIATED BY BACTERIA AT HIGHER LATITUDES

Photosynthetic microbes have long been recognized as supporting heterotrophic microbes and higher trophic life forms in polar

marine and terrestrial environments. Photosynthesizing and other microbes readily occupying the open terrestrial niche of uninhabitable land promote primary succession by improving soil organic matter and fertility (Figure 5).⁹⁶ These adaptive processes involved in terrestrialization are topical for understanding the colonization of microbes and plants on postglacial land emerging in polar regions as a result of anthropogenic climate warming.

The importance of microbes to soil quality and function are an established axiom. Mounting evidence has also revealed that microbes are ubiquitous and essential associates of plants and animals,^{26,66} and all living organisms share a universal and fundamental repertoire of chemical processes enabling interkingdom signaling.^{99–101} Chemical crosstalk among coevolving microbes and their hosts has been demonstrated to modulate ecologically relevant traits of the holobiont, including photosynthetic systems and improved tolerance to various abiotic and biotic stresses such as low temperatures, desiccation, and salinity.^{102–105} In addition to chemical signaling, endofungal and plant pathogenic microbes can directly regulate gene expression in their hosts via secreted transcription factors targeting host genes.^{106,107} We can therefore presume that microbes likely have evolved to chemically mediate the species with which they interact and coevolve. However, these interactions have been remarkably underexplored in polar regions, and currently, the role of interspecific crosstalk mediated via photochemical signaling between microbes and plants is virtually unexplored. Regarding plant adaptations in seasonally light-limited environments of higher latitudes, microbial phytochromes could be particularly prone to control adaptive plant functions because their activity state is controlled by red

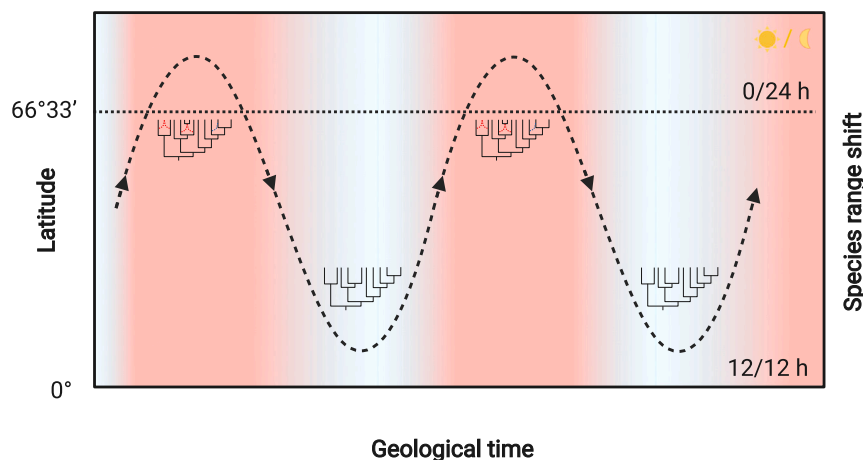

Figure 6. Species' range shifts across latitudes with different light environments during the cycles of the Earth's cooler and warmer periods in geological time

Phylogenetic trees indicate the relative importance of introgressive hybridization vs. bifurcating speciation (Figure 4) in adaptive divergence.

and reproductive phenology modulations of "holobiont hybrids."¹²²

CONSEQUENCES OF THE GEOLOGICAL TIMESCALE

In short, we hypothesize that hybridization and microbial cooperation play a significant role in maintaining and promoting

and far-red absorption properties of the photosensory protein,⁷³ thus balancing the outside and inside of the general plant chlorophyll *a* (Chl *a*) absorption region.¹⁰⁸ Furthermore, recent studies have shown that light quality controls the colonization, virulence, and conjugation of some plant pathogenic bacteria^{109–112} and microbes can contribute to plant fitness by altering their reproductive allocation and timing.^{113,114}

Genes encoding for light-sensitive proteins are susceptible to horizontal gene transfer (HGT),¹¹⁵ which is the dominant mode of protein innovation in bacteria.^{116–118} As it is well known that gene transfer from bacterial (e.g., *Agrobacterium fabrum*) to plant genomes takes place in nature and the laboratory,⁹⁹ and interdomain HGT is possible,^{115,119,120} we should not rule out that regulatory genes determining adaptive phenological timing can also be transmitted from bacteria to plants in evolutionary timescales.

We propose three avenues by which free-living and plant symbiotic bacteria with dynamic photoactivation capabilities can facilitate plant adaptations to seasonally light-limited terrestrial environments at higher latitudes (Figure 5A). First, microbes can improve the physical, chemical, and biological quality of soils by converting solar energy and dead organic matter into plant mineral nutrition (Figure 5A).^{61–63} Second, given that plants and associated microbes comprise multipartite holobiont entities,⁶⁶ we propose that soil and plant-associated microbes with high adaptive potential can facilitate plant adaptations via chemical crosstalk by releasing or modulating universal and evolutionarily conserved chemistry among the partners, thereby determining the adaptive phenological timing of the holobiont in the prevailing light environment (Figure 5B). Microbes can shift host phenology by, for example, altering nutrient acquisition, resource allocation, and hormonal pathways.¹²¹ Third, although extremely rare, regulatory genes determining adaptive phenological timing according to prevailing environmental cues may also be transmitted from the rich and dynamic photoreception palette of bacteria to plants in geological timescales (Figure 5A). The situation can be further complicated when invading plant-microbial symbiota adapted to different light environment come into contact with native species and their microbial symbionts. This may lead to horizontal transfer of symbiont assemblage between the host species and phenotypic

global biodiversity on a geological timescale for the following two reasons. First, because hybridization can increase the genetic variation in lineages and facilitate rapid speciation and adaptive radiation (especially if it involves ancestral variation derived from hybridization)^{1,4–7} circumpolar hybrid zones, together with recurrent cross-latitudinal migration of species, play an important role in maintaining global biodiversity on the geological timescale (Figure 6). Second, the resilience, maintenance, and regeneration of global biodiversity largely depend on the dispersal ability of compatible organisms being sufficient to retain the genetic variation required to cope with changing selection pressures and diversify. Myriad microbes, plants, and animals have been shown to be capable of dispersing into new areas worldwide,^{11,12} but the role of circumpolar hybrid zones and consequent hybrid speciation in maintaining the genetic admixture to support adaptive radiation and biological diversity on a geological timescale has been ignored.

OUTLOOK

As a theoretical and working framework, there are three main questions: (1) how should the proposed holistic framework be approached with the current tools, (2) do the novel insights contribute to the broader understanding of global biodiversity and its responses to environmental changes, and (3) what is the added value of the holistic approach over current practices to mitigate ongoing climate-change-driven biodiversity loss. Addressing these issues requires identification of biases and blind spots in contemporary research and scientific discourse. A majority of studies on climate-change-driven eco-evolutionary dynamics include (1) descriptions of threatened species and habitat destructions, (2) retrospective studies on fossil records or modern and archaic genomes, or (3) predictive approaches taking advantage of global open-access databases, bioinformatics, and computational biology. Yet, increasing understanding of the complexity of species interactions, genotype-environment interactions, genetic and epigenetic regulation, and other biological-context-dependent processes have revealed that experimental field studies testing how species respond to changing selection pressures are required before we can accurately predict the consequences of climate change on global

Box 2. Quantification of hybridization and HGT patterns across latitudes

Hybridization in eukaryotes (mostly in plants) and horizontal gene transfer (HGT) in prokaryotes (archaea and bacteria) are ongoing and frequent^{6,117} and one of the major sources of genetic innovation^{118,128} enabling the colonization of new environments.^{129,130} Phylogenomic analyses suggest that episodes of massive HGT were crucial for the emergence of major groups in archaea and eukaryotes.¹²⁸ Methods to detect hybridization^{131–133} and HGT^{128,134} are abundant in a wide range of disciplines. Here, we propose the use of genome-wide comparative analyses of phylogenetic¹³⁴ trees together with Bayes' conditional probabilities¹³⁵ to quantify gene exchange at different latitudes (Figure 4C). Tree comparison methods, such as the Tree-Net-Trend (TNT) score,¹³⁶ provide a direct measure of gene exchange (hybridization or HGT) within and across biogeographical regions. The TNT is based on the analysis of minimum evolutionary units (phylogenetic quartets) and quantifies the evolution of species in a scale from 0 (pure tree-like evolution) to 1 (pure network-like evolution). A simple Bayes' conditional probability model of hybridization probability $P(H)$, with only two parameters (Equation 1), that includes the probability to generate viable hybrids $P(h)$ and the probability of overlap (in a broad sense) between two species $P(o)$, may be used as a base model to explain broad differences in gene exchange across different latitudes.

$$P(H) = P(h) = \frac{P(o \cap h)}{P(h)} \quad \text{Equation 1}$$

biodiversity. This highlights the importance of empirical fact-finding to enable decisive actions that reduce biodiversity loss and the severity or irreversibility of disruptions to diverse ecosystem functions and services across the globe.

Here, we emphasized the importance of hybridization and microbial-mediated plant adaptations to light environments at higher latitudes (Figure 1). Hybridization has been known and discussed since at least the time of Linnaeus.⁶ After decades of absence, the importance of hybridization resurfaced in the context of recurrent glacial periods promoting genome reorganization in Hewitt's 1996 paper, "Some genetic consequences of ice ages, and their role in divergence and speciation."⁴² Since then, advances in molecular microbiology have revolutionized the ability of scientists to study genetic diversity and hybridization, and this has led to an extreme abundance of literature on the topic. To date, genetic variation and gene combinations resulting from hybridization have been detected in at least 10% of animal and 25% of plant species.⁷ However, much of the scientific, and particularly the public, discussion of biodiversity loss continues to be species-centric and centered on animals and plants. Modeling of the laws of functional diversity by taking into account maintenance of phylogenetic potential has been suggested.¹²³ However, we would still include, in future models, hybridization as a potential source to maintain phylogenetic biodiversity. We are still just beginning to understand the importance of microbial diversity and how microbes may facilitate hybrid speciation of their hosts and promote the genetic diversity necessary to adapt to new or changing selection pressures.^{66,124}

We argue that tackling climate-change-driven biodiversity loss would benefit greatly from a stronger knowledge base that can advance our thinking on biological diversity beyond the species level and bring to the fore the fact that we must assure that sufficient genetic potential will remain^{5,125} to support the associated ecosystem functions and services on Earth in the future. Here, we hypothesize that microbes, and especially their light responses and photochemistry, may play an important role in promoting global biodiversity. Interdisciplinary experimental approaches are required to test the hypotheses that genetic light

sensitivity, photochemistry, and induced responses facilitate microbial-mediated plant adaptations to seasonally differentiated light environments and that the seasonality of day length promotes the maintenance of circumpolar hybrid zones at higher latitudes, thereby playing an important role in maintaining biodiversity globally. Interdisciplinary research to assess these topics should combine (1) molecular genetics and genome-wide comparative genomics to examine both global-scale dispersal and connectivity of microbes and their host organisms, as well as to trace evidence for ancient and recent hybridization across latitudes^{117,126}; (2) research on chemical ecology probing ecologically relevant molecular signals and biosynthetic responses of microbe-host plant interactions^{102–105}; (3) empirical ecology using, e.g., reciprocal transplant experiments across latitudes to test the importance of the light environment on the timing of reproduction¹²⁷; (4) crossbreeding experiments to test species potential to hybridization; and (5) computational biology to assess the contributions of the abiotic environment and species interactions to genetic diversity and phenotypic plasticity (Figure 1E).

For example, light-dependent variation in bacteria across latitudes at genes, pangenomes, and microbial communities can be quantified with phylogenetics and probabilistic models.¹¹⁵ (Box 2). In addition to providing a theoretical understanding of how novel species assemblages may arise in the circumpolar region at a geological timescale, a practical application of the framework's incorporation of microbes, light regimes, and photosensitivity should be considered in risk assessments and used in the development of sustainable agricultural and forest practices. Particularly relevant for future food security and sustainable use of natural resources is the modeling and prediction of production ranges as climate heating shifts agriculture and forestry to higher latitudes. Range limits for production will need to take into consideration (1) ecological mismatch in essential ecosystem services such as pollination, (2) research and development for species and varieties suitable to the available light regimes, and (3) the plant-microbial communities and microbial mediation that facilitate crop adaptations and production.

ACKNOWLEDGMENTS

We thank I. Saloniemi and Nick Walter for invaluable comments on the manuscript, Moona Kurttila for preparing Figure 5B, and Otto Saikkonen for preparing the world climate maps. This work was supported by the Research Council of Finland (project numbers 295976 and 326226 to K.S. and 332742 to J.A.I.). In the author list, the corresponding author is listed first, after which other authors were listed in alphabetical order.

AUTHOR CONTRIBUTIONS

K.S. conceived the idea and drafted the text. All authors reviewed and edited the paper.

DECLARATION OF INTERESTS

The authors declare no competing interests.

REFERENCES

- Marques, D.A., Meier, J.I., and Seehausen, O. (2019). A combinatorial view on speciation and adaptive radiation. *Trends Ecol. Evol.* 34, 531–544. <https://doi.org/10.1016/j.tree.2019.02.008>.
- Abbott, R., Albach, D., Ansell, S., Arntzen, J.W., Baird, S.J.E., Bierne, N., Boughman, J., Brelsford, A., Buerkle, C.A., Buggs, R., et al. (2013). Hybridization and speciation. *J. Evol. Biol.* 26, 229–246. <https://doi.org/10.1111/j.1420-9101.2012.02599.x>.
- Taylor, S.A., Larson, E.L., and Harrison, R.G. (2015). Hybrid zones: windows on climate change. *Trends Ecol. Evol.* 30, 398–406. <https://doi.org/10.1016/j.tree.2015.04.010>.
- Gompert, Z., Mandeville, E.G., and Buerkle, C.A. (2017). Analysis of population genomic data from hybrid zones. *Annu. Rev. Ecol. Syst.* 48, 207–229. <https://doi.org/10.1146/annurev-ecolsys-110316-022652>.
- Grant, P.R., and Grant, B.R. (2019). Hybridization increases population variation during adaptive radiation. *Proc. Natl. Acad. Sci. USA* 116, 23216–23224. <https://doi.org/10.1073/pnas.1913534116>.
- Mallet, J. (2005). Hybridization as an invasion of the genome. *Trends Ecol. Evol.* 20, 229–237. <https://doi.org/10.1016/j.tree.2005.02.010>.
- Mallet, J. (2007). Hybrid speciation. *Nature* 446, 279–283. <https://doi.org/10.1038/nature05706>.
- Edelman, N.B., and Mallet, J. (2021). The prevalence and adaptive impact of introgression. *Annu. Rev. Genet.* 55, 265–283. <https://doi.org/10.1146/annurev-genet-021821-020805>.
- Zhou, B.-F., Yuan, S., Crowl, A.A., Liang, Y.-Y., Shi, Y., Chen, X.-Y., An, Q.-Q., Kang, M., Manos, P.S., and Wang, B. (2022). Phylogenomic analyses highlight innovation and introgression in the continental radiations of Fagaceae across the Northern Hemisphere. *Nat. Commun.* 13, 1320. <https://doi.org/10.1038/s41467-022-28917-1>.
- Draper, D., Laguna, E., and Marques, I. (2021). Demystifying negative connotations of hybridization for less biased conservation policies. *Front. Ecol. Evol.* 9, 637100. <https://doi.org/10.3389/fevo.2021.637100>.
- Saikkonen, K., Dirihan, S., Väre, H., Saloniemi, I., Cräutlein, M., Leinonen, P.H., and Helander, M. (2019). Phenotypic and genetic variation in natural populations of *Festuca rubra* s. l. in Europe. *Plant Ecol. Divers.* 12, 441–456. <https://doi.org/10.1080/17550874.2019.1654551>.
- van Kleunen, M., Dawson, W., Essl, F., Pergl, J., Winter, M., Weber, E., Kreft, H., Weigelt, P., Kartesz, J., Nishino, M., et al. (2015). Global exchange and accumulation of non-native plants. *Nature* 525, 100–103. <https://doi.org/10.1038/nature14910>.
- Nahrung, H.F., Liebhold, A.M., Brockerhoff, E.G., and Rassati, D. (2023). Forest insect biosecurity: Processes, patterns, predictions, pitfalls. *Annu. Rev. Entomol.* 68, 211–229. <https://doi.org/10.1146/annurev-ento-120220-010854>.
- Charles, K.M., and Stehlik, I. (2021). Assisted species migration and hybridization to conserve cold-adapted plants under climate change. *Conserv. Biol.* 35, 559–566. <https://doi.org/10.1111/cobi.13583>.
- Cohen, J., Screen, J.A., Furtado, J.C., Barlow, M., Whittleston, D., Coumou, D., Francis, J., Dethloff, K., Entekhabi, D., Overland, J., and Jones, J. (2014). Recent Arctic amplification and extreme mid-latitude weather. *Nat. Geosci.* 7, 627–637. <https://doi.org/10.1038/NGEO2234>.
- Polvani, L.M., Previdi, M., England, M.R., Chiodo, G., and Smith, K.L. (2020). Substantial twentieth-century Arctic warming caused by ozone-depleting substances. *Nat. Clim. Chang.* 10, 130–133. <https://doi.org/10.1038/s41558-019-0677-4>.
- Rantanen, M., Karpechko, A.Y., Lipponen, A., Nordling, K., Hyvärinen, O., Ruosteenoja, K., Vihma, T., and Laaksonen, A. (2022). The Arctic has warmed nearly four times faster than the globe since 1979. *Commun. Earth Environ.* 3, 168. <https://doi.org/10.1038/s43247-022-00498-3>.
- Ditlevsen, P., and Ditlevsen, S. (2023). Warning of a forthcoming collapse of the Atlantic meridional overturning circulation. *Nat. Commun.* 14, 4254. <https://doi.org/10.1038/s41467-023-39810-w>.
- Urban, M.C. (2018). Escalator to extinction. *Proc. Natl. Acad. Sci. USA* 115, 11871–11873. <https://doi.org/10.1073/pnas.1817416115>.
- Saikkonen, K., Taulavuori, K., Hyvönen, T., Gundel, P.E., Hamilton, C.E., Vänninen, I., Nissinen, A., and Helander, M. (2012). Climate change-driven species' range shifts filtered by photoperiodism. *Nat. Clim. Change* 2, 239–242. <https://doi.org/10.1038/Nclimate1430>.
- Kelly, B.P., Whiteley, A., and Tallmon, D. (2010). The Arctic melting pot. *Nature* 468, 891. <https://doi.org/10.1038/468891a>.
- Thackeray, C.W., and Hall, A. (2019). An emergent constraint on future Arctic sea-ice albedo feedback. *Nat. Clim. Change* 9, 972–978. <https://doi.org/10.1038/s41558-019-0619-1>.
- Lee, J.R., Raymond, B., Bracegirdle, T.J., Chadès, I., Fuller, R.A., Shaw, J.D., and Terauds, A. (2017). Climate change drives expansion of Antarctic ice-free habitat. *Nature* 547, 49–54. <https://doi.org/10.1038/nature22996>.
- Anderson, E. (1948). Hybridization of the habitat. *Evolution* 2, 1–9. <https://doi.org/10.2307/2405610>.
- Barton, N.H., and Hewitt, G.M. (1989). Adaptation, speciation and hybrid zones. *Nature* 341, 497–503. <https://doi.org/10.1038/341497a0>.
- Hewitt, G.M. (2011). Quaternary phylogeography: the roots of hybrid zones. *Genetics* 139, 617–638. <https://doi.org/10.1007/s10709-011-9547-3>.
- Soltis, P.S., and Soltis, D.E. (2009). The role of hybridization in plant speciation. *Annu. Rev. Plant Biol.* 60, 561–588. <https://doi.org/10.1146/annurev.arplant.043008.092039>.
- Kleindorfer, S., O'Connor, J.A., Dudaniec, R.Y., Myers, S.A., Robertson, J., and Sulloway, F.J. (2014). Species collapse via hybridization in Darwin's tree finches. *Am. Nat.* 183, 325–341. <https://doi.org/10.1086/674899>.
- Marie Curie SPECIATION Network, Butlin, R., Debelle, A., Kerth, C., Snook, R.R., Beukeboom, L.W., Castillo Cajas, R.F., Diao, W., Maan, M.E., Paolucci, S., et al. (2012). What do we need to know about speciation? *Trends Ecol. Evol.* 27, 27–39. <https://doi.org/10.1016/j.tree.2011.09.002>.
- Chen, I.C., Hill, J.K., Ohlemüller, R., Roy, D.B., and Thomas, C.D. (2011). Rapid range shifts of species associated with high levels of climate warming. *Science* 333, 1024–1026. <https://doi.org/10.1126/science.1206432>.
- Tewksbury, J.J., Sheldon, K.S., and Ettinger, A.K. (2011). Moving farther and faster. *Nat. Clim. Change* 1, 396–397. <https://doi.org/10.1038/nclimate1266>.
- Walter, G.-R., Roques, A., Hulme, P.E., Sykes, M.T., Pyšek, P., Kühn, I., and Zobel, M. (2009). Alien species in a warmer world: risks and opportunities. *Trends Ecol. Evol.* 24, 686–693. <https://doi.org/10.1016/j.tree.2009.06.008>.
- Alcala, N., and Vuilleumier, S. (2014). Turnover and accumulation of genetic diversity across large time-scale cycles of isolation and connection of populations. *Proc. Biol. Sci.* 281, 20141369. <https://doi.org/10.1098/rspb.2014.1369>.
- Chunco, A.J. (2014). Hybridization in a warmer world. *Ecol. Evol.* 4, 2019–2031. <https://doi.org/10.1002/ece3.1052>.
- Hamilton, J.A., and Miller, J.M. (2016). Adaptive introgression as a resource for management and genetic conservation in a changing climate. *Conserv. Biol.* 30, 33–41. <https://doi.org/10.1111/cobi.12574>.
- Árnason, E., and Halldórsdóttir, K. (2019). Codweb: Whole-genome sequencing uncovers extensive reticulations fueling adaptation among Atlantic, Arctic, and Pacific gadids. *Sci. Adv.* 5, eaat8788. <https://doi.org/10.1126/sciadv.aat8788>.
- Colella, J.P., Lan, T., Schuster, S.C., Talbot, S.L., Cook, J.A., and Lindqvist, C. (2018). Whole-genome analysis of *Mustela erminea* finds that pulsed hybridization impacts evolution at high latitudes. *Commun. Biol.* 1, 51. <https://doi.org/10.1038/s42003-018-0058-y>.
- Heide-Jørgensen, M.P., Laidre, K.L., Quakenbush, L.T., and Citta, J.J. (2012). The Northwest Passage opens for bowhead whales. *Biol. Lett.* 8, 270–273. <https://doi.org/10.1098/rsbl.2011.0731>.
- Miller, W., Schuster, S.C., Welch, A.J., Ratan, A., Bedoya-Reina, O.C., Zhao, F., Kim, H.L., Burhans, R.C., Drautz, D.I., Wittekindt, N.E., et al. (2012). Polar and brown bear genomes reveal ancient admixture and

- demographic footprints of past climate change. *Proc. Natl. Acad. Sci. USA* 109, E2382–E2390. <https://doi.org/10.1073/pnas.1210506109>.
40. Wagner, N.D., He, L., and Hörandl, E. (2021). The evolutionary history, diversity, and ecology of willows (*Salix* L.) in the European Alps. *Diversity* 13, 146. <https://doi.org/10.3390/d13040146>.
 41. Cronk, Q., Ruzzier, E., Belyaeva, I., and Percy, D. (2015). *Salix* transect of Europe: latitudinal patterns in willow diversity from Greece to rctic Norway. *Biodivers. Data J.* 3, e6258. <https://doi.org/10.3897/BDJ.3.e6258>.
 42. Hewitt, G. (1996). Some genetic consequences of ice ages, and their role in divergence and speciation. *Biol. J. Linn. Soc.* 58, 247–276. <https://doi.org/10.1006/bjil.1996.0035>.
 43. Larson, E.L., Tinghitella, R.M., and Taylor, S.A. (2019). Insect hybridization and climate change. *Front. Ecol. Evol.* 7, 348. <https://doi.org/10.3389/fevo.2019.00348>.
 44. Nelson, R.J., Denlinger, D.L., and Somers, D.E. (2010). *Photoperiodism, the Biological Calendar* (Oxford University Press).
 45. Bradshaw, W.E., and Holzapfel, C.M. (2007). Evolution of animal photoperiodism. *Annu. Rev. Ecol. Syst.* 38, 1–25. <https://doi.org/10.1146/annurev.ecolsys.37.091305.110115>.
 46. Körner, C., and Basler, D. (2010). Phenology under global warming. *Science* 327, 1461–1462. <https://doi.org/10.1126/science.1186473>.
 47. Sockman, K.W., and Hurlbert, A.H. (2020). How the effects of latitude on daylight availability may have influenced the evolution of migration and photoperiodism. *Funct. Ecol.* 34, 1752–1766. <https://doi.org/10.1111/1365-2435.13578>.
 48. Bradshaw, W.E., and Holzapfel, C.M. (2006). Evolutionary response to rapid climate change. *Science* 312, 1477–1478. <https://doi.org/10.1126/science.1127000>.
 49. Menzel, A., Sparks, T.H., Estrella, N., Koch, E., Aasa, A., Ahas, R., Alm-Kübler, K., Bissolli, P., Braslavská, O., Briede, A., et al. (2006). European phenological response to climate change matches the warming pattern. *Glob. Chang. Biol.* 12, 1969–1976. <https://doi.org/10.1111/j.1365-2486.2006.01193.x>.
 50. Dugle, J.R. (1966). A taxonomic study of western Canadian species in the genus *Betula*. *Can. J. Bot.* 44, 929–1007. <https://doi.org/10.1139/b66-106>.
 51. Palme, A.E., Su, Q., Palsson, S., and Lascoux, M. (2004). Extensive sharing of chloroplast haplotypes among European birches indicates hybridization among *Betula pendula*, *B. pubescens* and *B. nana*. *Mol. Ecol.* 13, 167–178. <https://doi.org/10.1046/j.1365-294X.2003.02034.x>.
 52. Hanski, I. (1999). *Metapopulation Ecology* (Oxford University Press).
 53. Ottenburghs, J. (2019). Multispecies hybridization in birds. *Avian Res.* 10, 20. <https://doi.org/10.1186/s40657-019-0159-4>.
 54. Tsuda, Y., Semerikov, V., Sebastiani, F., Vendramin, G.G., and Lascoux, M. (2017). Multispecies genetic structure and hybridization in the *Betula* genus across Eurasia. *Mol. Ecol.* 26, 589–605. <https://doi.org/10.1111/mec.13885>.
 55. Anderson, E. (1949). *Introgressive Hybridization* (Wiley).
 56. Avise, J.C., Nelson, W.S., Arnold, J., Koehn, R.K., Williams, G.C., and Thorsteinsson, V. (1990). The evolutionary genetic status of Icelandic eels. *Evolution* 44, 1254–1262. <https://doi.org/10.1111/j.1558-5646.1990.tb05229.x>.
 57. Grant, P.R., and Grant, B.R. (1992). Hybridization of bird species. *Science* 256, 193–197. <https://doi.org/10.1126/science.256.5054.193>.
 58. Hewitt, G. (2000). The genetic legacy of the Quaternary ice ages. *Nature* 405, 907–913. <https://doi.org/10.1038/35016000>.
 59. Miralles, L., Oremus, M., Silva, M.A., Planes, S., and Garcia-Vazquez, E. (2016). Interspecific hybridization in pilot whales and asymmetric genetic introgression in northern *Globicephala melas* under the scenario of global warming. *PLoS One* 11, e0160080. <https://doi.org/10.1371/journal.pone.0160080>.
 60. Payne, R.H., Child, A.R., and Forrest, A. (1972). The existence of natural hybrids between the European trout and the Atlantic salmon. *J. Fish. Biol.* 4, 233–236. <https://doi.org/10.1111/j.1095-8649.1972.tb05669.x>.
 61. Bradley, J.A., Singarayer, J.S., and Anesio, A.M. (2014). Microbial community dynamics in the forefield of glaciers. *Proc. Biol. Sci.* 281, 20140882. <https://doi.org/10.1098/rspb.2014.0882>.
 62. Rime, T., Hartmann, M., and Frey, B. (2016). Potential sources of microbial colonizers in an initial soil ecosystem after retreat of an alpine glacier. *ISME J.* 10, 1625–1641. <https://doi.org/10.1038/ismej.2015.238>.
 63. Varliero, G., Anesio, A.M., and Barker, G.L.A. (2021). A taxon-wise insight into rock weathering and nitrogen fixation functional profiles of proglacial systems. *Front. Microbiol.* 12, 627437. <https://doi.org/10.3389/fmicb.2021.627437>.
 64. Rosenberg, E., and Zilber-Rosenberg, I. (2016). Microbes drive evolution of animals and plants: the hologenome concept. *mBio* 7, e01395. <https://doi.org/10.1128/mBio.01395-15>.
 65. Gilbert, J.A., Blaser, M.J., Caporaso, J.G., Jansson, J.K., Lynch, S.V., and Knight, R. (2018). Current understanding of the human microbiome. *Nat. Med.* 24, 392–400. <https://doi.org/10.1038/nm.4517>.
 66. Saikkonen, K., Nissinen, R., and Helander, M. (2020). Toward comprehensive plant microbiome research. *Front. Ecol. Evol.* 8, 61. <https://doi.org/10.3389/fevo.2020.00061>.
 67. Vandenkoornhuysse, P., Quaiser, A., Duhamel, M., Le Van, A., and Dufresne, A. (2015). The importance of microbiome of the plant holobiont. *New Phytol.* 206, 119–126. <https://doi.org/10.1111/nph.13312>.
 68. Mesny, F., Hacquard, S., and Thomma, B.P. (2023). Co-evolution within the plant holobiont drives host performance. *EMBO Rep.* 24, e57455. <https://doi.org/10.15252/embr.202357455>.
 69. Thompson, J.N. (2005). *The Geographic Mosaic of Coevolution* (University of Chicago Press).
 70. Partida-Martinez, L.P., and Heil, M. (2011). The microbe-free plant: fact or artifact? *Front. Plant Sci.* 2, 100. <https://doi.org/10.3389/fpls.2011.00100>.
 71. Li, J.-H., Muhammad Aslam, M., Gao, Y.-Y., Dai, L., Hao, G.-F., Wei, Z., Chen, M.-X., and Dini-Andreote, F. (2023). Microbiome-mediated signal transduction within the plant holobiont. *Trends Microbiol.* 31, 616–628. <https://doi.org/10.1016/j.tim.2022.12.005>.
 72. Losi, A., and Gärtner, W. (2021). A light together: photosensing in the plant microbiota. *Photochem. Photobiol. Sci.* 20, 451–473. <https://doi.org/10.1007/s43630-021-00029-7>.
 73. Rockwell, N.C., Su, Y.-S., and Lagarias, J.C. (2006). Phytochrome structure and signaling mechanisms. *Annu. Rev. Plant Biol.* 57, 837–858. <https://doi.org/10.1146/annurev.arplant.56.032604.144208>.
 74. Landenmark, H.K.E., Forgan, D.H., and Cockell, C.S. (2015). An estimate of the total DNA in the biosphere. *PLoS Biol.* 13, e1002168. <https://doi.org/10.1371/journal.pbio.1002168>.
 75. Finlay, B.J. (2002). Global dispersal of free-living microbial eukaryote species. *Science* 296, 1061–1063. <https://doi.org/10.1126/science.1070710>.
 76. Oren, A. (2002). Molecular ecology of extremely halophilic Archaea and Bacteria. *FEMS Microbiol. Ecol.* 39, 1–7. <https://doi.org/10.1111/j.1574-6941.2002.tb00900.x>.
 77. Swan, B.K., Tupper, B., Sczyrba, A., Lauro, F.M., Martinez-Garcia, M., González, J.M., Luo, H., Wright, J.J., Landry, Z.C., Hanson, N.W., et al. (2013). Prevalent genome streamlining and latitudinal divergence of planktonic bacteria in the surface ocean. *Proc. Natl. Acad. Sci. USA* 110, 11463–11468. <https://doi.org/10.1073/pnas.1304246110>.
 78. Malard, L.A., and Pearce, D.A. (2018). Microbial diversity and biogeography in Arctic soils. *Environ. Microbiol. Rep.* 10, 611–625. <https://doi.org/10.1111/1758-2229.12680>.
 79. Holmberg, S.M., and Jørgensen, N.O.G. (2023). Insights into abundance, adaptation and activity of prokaryotes in arctic and Antarctic environments. *Polar Biol.* 46, 381–396. <https://doi.org/10.1007/s00300-023-03137-5>.
 80. Nissinen, R.M., Männistö, M.K., and van Elsas, J.D. (2012). Endophytic bacterial communities in three arctic plants from low arctic fell tundra are cold-adapted and host-plant specific. *FEMS Microbiol. Ecol.* 82, 510–522. <https://doi.org/10.1111/j.1574-6941.2012.01464.x>.
 81. Poosakkannu, A., Nissinen, R., and Kytöviita, M.-M. (2015). Culturable endophytic microbial communities in the circumpolar grass, *Deschampsia flexuosa* in a sub-Arctic inland primary succession are habitat and growth stage specific. *Environ. Microbiol. Rep.* 7, 111–122. <https://doi.org/10.1111/1758-2229.12195>.
 82. Rosa, L.H., Vaz, A.B.M., Caligiorno, R.B., Campolina, S., and Rosa, C.A. (2009). Endophytic fungi associated with the Antarctic grass *Deschampsia antarctica* Desv. (Poaceae). *Polar Biol.* 32, 161–167. <https://doi.org/10.1007/s00300-008-0515-z>.
 83. Pisciotto, J.M., Zou, Y., and Baskakov, I.V. (2010). Light-dependent electrogenic activity of Cyanobacteria. *PLoS One* 5, e10821. <https://doi.org/10.1371/journal.pone.0010821>.
 84. Antonaru, L.A., Cardona, T., Larkum, A.W.D., and Nürnberg, D.J. (2020). Global distribution of a chlorophyll f cyanobacterial marker. *ISME J.* 14, 2275–2287. <https://doi.org/10.1038/s41396-020-0670-y>.
 85. Nissinen, R., Franz, O., Kovanen, S., Mäkelä, M., Kraft, V., Ketola, K., Liukkonen, A., Heikkilä-Huhta, K., Häkkinen, H., and Ihalainen, J.A. (2023). Aerobic anoxygenic phototrophic bacteria are ubiquitous in phyllo- and endosphere microbiomes of boreal and subarctic plants. Preprint at bioRxiv. <https://doi.org/10.1101/2023.02.19.529139>.

86. Inoue, K., Tsukamoto, T., and Sudo, Y. (2014). Molecular and evolutionary aspects of microbial sensory rhodopsins. *Biochim. Biophys. Acta* 1837, 562–577. <https://doi.org/10.1016/j.bbabi.2013.05.005>.
87. Béjà, O., Aravind, L., Koonin, E.V., Suzuki, M.T., Hadd, A., Nguyen, L.P., Jovanovich, S.B., Gates, C.M., Feldman, R.A., Spudich, J.L., et al. (2000). Bacterial rhodopsin: Evidence for a new type of phototrophy in the sea. *Science* 289, 1902–1906. <https://doi.org/10.1126/science.289.5486.1902>.
88. Kirchman, D.L., and Hanson, T.E. (2013). Bioenergetics of photoheterotrophic bacteria in the oceans. *Environ. Microbiol. Rep.* 5, 188–199. <https://doi.org/10.1111/j.1758-2229.2012.00367.x>.
89. Oesterhelt, D., and Tittor, J. (1989). Two pumps, one principle: light-driven ion transport in halobacteria. *Trends Biochem. Sci.* 14, 57–61. [https://doi.org/10.1016/0968-0004\(89\)90044-3](https://doi.org/10.1016/0968-0004(89)90044-3).
90. Cottrell, M.T., and Kirchman, D.L. (2009). Photoheterotrophic microbes in the Arctic Ocean in summer and winter. *Appl. Environ. Microbiol.* 75, 4958–4966. <https://doi.org/10.1128/AEM.00117-09>.
91. González, J.M., Pinhassi, J., Fernández-Gómez, B., Coll-Lladó, M., González-Velázquez, M., Puigbò, P., Jaenicke, S., Gómez-Consarnau, L., Fernández-Guerra, A., Goemann, A., and Pedrós-Alió, C. (2011). Genomics of the proteorhodopsin-containing marine flavobacterium *Dokdonia* sp. strain MED134. *Appl. Environ. Microbiol.* 77, 8676–8686. <https://doi.org/10.1128/AEM.06152-11>.
92. Kopejtká, K., Tomasch, J., Zeng, Y., Selyanin, V., Dachev, M., Piwosz, K., Tichý, M., Bina, D., Gardian, Z., Bunk, B., et al. (2020). Simultaneous presence of bacteriochlorophyll and xanthorhodopsin genes in a freshwater bacterium. *mSystems* 5, e01044-20. <https://doi.org/10.1128/mSystems.01044-20>.
93. Ihalainen, J.A., Dogan, B., Kurttila, M., Zeng, Y., van Elsas, J.D., and Nissinen, R. (2024). Multifaceted photoreceptor compositions in dual phototrophic systems - a genomic analysis. *J. Mol. Biol.* 436, 168412. <https://doi.org/10.1016/j.jmb.2023.168412>.
94. Atamna-Ismaeel, N., Finkel, O.M., Glaser, F., Sharon, I., Schneider, R., Post, A.F., Spudich, J.L., von Mering, C., Vorholt, J.A., Iluz, D., et al. (2012). Microbial rhodopsins on leaf surfaces of terrestrial plants. *Environ. Microbiol.* 14, 140–146. <https://doi.org/10.1111/j.1462-2920.2011.02554.x>.
95. Yutin, N., and Koonin, E.V. (2012). Proteorhodopsin genes in giant viruses. *Biol. Direct* 7, 34. <https://doi.org/10.1186/1745-6150-7-34>.
96. Wellman, C.H., and Strother, P.K. (2015). The terrestrial biota prior to the origin of land plants (embryophytes): a review of the evidence. *Palaeontology* 58, 601–627. <https://doi.org/10.1111/pala.12172>.
97. Takala, H., Björling, A., Berntsson, O., Lehtivuori, H., Niebling, S., Hoernke, M., Kosheleva, I., Henning, R., Menzel, A., Ihalainen, J.A., and Westenhoff, S. (2014). Signal amplification and transduction in phytochrome photosensors. *Nature* 509, 245–248. <https://doi.org/10.1038/nature13310>.
98. Multamäki, E., Nanekar, R., Morozov, D., Lievonon, T., Golonka, D., Wahlgren, W.Y., Stucki-Buchli, B., Rossi, J., Hytönen, V.P., Westenhoff, S., et al. (2021). Comparative analysis of two paradigm bacteriophytochromes reveals opposite functionalities in two-component signaling. *Nat. Commun.* 12, 4394. <https://doi.org/10.1038/s41467-021-24676-7>.
99. Gelvin, S.B. (2003). *Agrobacterium*-mediated plant transformation: the biology behind the “gene-jockeying” tool. *Microbiol. Mol. Biol. Rev.* 67, 16–37. <https://doi.org/10.1128/MMBR.67.1.16-37.2003>.
100. Hamilton, C.E., Gundel, P.E., Helander, M., and Saikkonen, K. (2012). Endophytic mediation of reactive oxygen species and antioxidant activity in plants: a review. *Fungal Divers.* 54, 1–10. <https://doi.org/10.1007/s13225-012-0158-9>.
101. Saikkonen, K., Gundel, P.E., and Helander, M. (2013). Chemical ecology mediated by fungal endophytes in grasses. *J. Chem. Ecol.* 39, 962–968. <https://doi.org/10.1007/s10886-013-0310-3>.
102. Seyedsayamdost, M.R., Case, R.J., Kolter, R., and Clardy, J. (2011). The Jekyll-and-Hyde chemistry of *Phaeobacter gallaeciensis*. *Nat. Chem.* 3, 331–335. <https://doi.org/10.1038/nchem.1002>.
103. Sharma, M.P., Grover, M., Chourasiya, D., Bharti, A., Agnihotri, R., Maheshwari, H.S., Pareek, A., Buyer, J.S., Sharma, S.K., Schütz, L., et al. (2020). Deciphering the role of trehalose in tripartite symbiosis among rhizobia, arbuscular mycorrhizal fungi, and legumes for enhancing abiotic stress tolerance in crop plants. *Front. Microbiol.* 11, 509919. <https://doi.org/10.3389/fmicb.2020.509919>.
104. Raza, A., Su, W., Jia, Z., Luo, D., Zhang, Y., Gao, A., Hussain, M.A., Mehmood, S.S., Cheng, Y., Lv, Y., and Zou, X. (2022). Mechanistic insights into trehalose-mediated cold stress tolerance in rapeseed (*Brassica napus* L.) seedlings. *Front. Plant Sci.* 13, 857980. <https://doi.org/10.3389/fpls.2022.857980>.
105. Shaffer, J.M.C., Giddings, L.A., Samples, R.M., and Mikucki, J.A. (2023). Genomic and phenotypic characterization of a red-pigmented strain of *Massilia frigida* isolated from an Antarctic microbial mat. *Front. Microbiol.* 14, 1156033. <https://doi.org/10.3389/fmicb.2023.1156033>.
106. Carter, M.E., Carpenter, S.C.D., Dubrow, Z.E., Sabol, M.R., Rinaldi, F.C., Lastovetsky, O.A., Mondo, S.J., Pawlowska, T.E., and Bogdanove, A.J. (2020). A TAL effector-like protein of an endofungal bacterium increases the stress tolerance and alters the transcriptome of the host. *Proc. Natl. Acad. Sci. USA* 117, 17122–17129. <https://doi.org/10.1073/pnas.2003857117>.
107. Zhang, B., Han, X., Yuan, W., and Zhang, H. (2022). TALEs as double-edged swords in plant-pathogen interactions: Progress, challenges, and perspectives. *Plant Commun.* 3, 100318. <https://doi.org/10.1016/j.xplc.2022.100318>.
108. Lee, D.W., and Graham, R. (1986). Leaf optical properties of rainforest sun and extreme shade plants. *Am. J. Bot.* 73, 1100–1108. <https://doi.org/10.1002/j.1537-2197.1986.tb08557.x>.
109. Bai, Y., Rottwinkel, G., Feng, J., Liu, Y., and Lamparter, T. (2016). Bacteriophytochromes control conjugation in *Agrobacterium fabrum*. *J. Photochem. Photobiol., B* 161, 192–199. <https://doi.org/10.1016/j.jphotobiol.2016.05.014>.
110. Bonomi, H.R., Toum, L., Sycz, G., Sieira, R., Toscani, A.M., Gudesblat, G.E., Leskow, F.C., Goldbaum, F.A., Vojnov, A.A., and Malamud, F. (2016). *Xanthomonas campestris* attenuates virulence by sensing light through a bacteriophytochrome photoreceptor. *EMBO Rep.* 17, 1565–1577. <https://doi.org/10.15252/embr.201541691>.
111. Santamaría-Hernando, S., Rodríguez-Herva, J.J., Martínez-García, P.M., Río-Álvarez, I., González-Melendi, P., Zamorano, J., Tapia, C., Rodríguez-Palenzuela, P., and López-Solanilla, E. (2018). *Pseudomonas syringae* pv. tomato exploits light signals to optimize virulence and colonization of leaves. *Environ. Microbiol.* 20, 4261–4280. <https://doi.org/10.1111/1462-2920.14331>.
112. Xue, P., Bai, Y., Rottwinkel, G., Averbukh, E., Ma, Y., Roeder, T., Scherer, P., Krauß, N., and Lamparter, T. (2021). Phytochrome mediated responses in *Agrobacterium fabrum*: Growth, motility and plant infection. *Curr. Microbiol.* 78, 2708–2719. <https://doi.org/10.1007/s00284-021-02526-5>.
113. Wagner, M.R., Lundberg, D.S., Coleman-Derr, D., Tringe, S.G., Dangl, J.L., and Mitchell-Olds, T. (2014). Natural soil microbes alter flowering phenology and the intensity of selection on flowering time in a wild *Arabidopsis* relative. *Ecol. Lett.* 17, 717–726. <https://doi.org/10.1111/ele.12276>.
114. Zahn, G., and Amend, A.S. (2019). Foliar fungi alter reproductive timing and allocation in *Arabidopsis* under normal and water-stressed conditions. *Fungal Ecol.* 41, 101–106. <https://doi.org/10.1016/j.funeco.2019.04.002>.
115. Frigaard, N.-U., Martinez, A., Mincer, T.J., and DeLong, E.F. (2006). Proteorhodopsin lateral gene transfer between marine planktonic Bacteria and Archaea. *Nature* 439, 847–850. <https://doi.org/10.1038/nature04435>.
116. Ochman, H., Lawrence, J.G., and Groisman, E.A. (2000). Lateral gene transfer and the nature of bacterial innovation. *Nature* 405, 299–304. <https://doi.org/10.1038/35012500>.
117. Puigbò, P., Lobkovsky, A.E., Kristensen, D.M., Wolf, Y.I., and Koonin, E.V. (2014). Genomes in turmoil: quantification of genome dynamics in prokaryote supergenomes. *BMC Biol.* 12, 66. <https://doi.org/10.1186/s12915-014-0066-4>.
118. Treangen, T.J., and Rocha, E.P.C. (2011). Horizontal transfer, not duplication, drives the expansion of protein families in prokaryotes. *PLoS Genet.* 7, e1001284. <https://doi.org/10.1371/journal.pgen.1001284>.
119. Yue, J., Hu, X., Sun, H., Yang, Y., and Huang, J. (2012). Widespread impact of horizontal gene transfer on plant colonization of land. *Nat. Commun.* 3, 1152. <https://doi.org/10.1038/ncomms2148>.
120. Sieber, K.B., Bromley, R.E., and Dunning Hotopp, J.C. (2017). Lateral gene transfer between prokaryotes and eukaryotes. *Exp. Cell Res.* 358, 421–426. <https://doi.org/10.1016/j.yexcr.2017.02.009>.
121. O'Brien, A.M., Ginnan, N.A., Rebollada-Gómez, M., and Wagner, M.R. (2021). Microbial effects on plant phenology and fitness. *Am. J. Bot.* 108, 1824–1837. <https://doi.org/10.1002/ajb2.1743>.
122. Kowalski, K.P., Bacon, C., Bickford, W., Braun, H., Clay, K., Leduc-Lapierre, M., Lillard, E., McCormick, M.K., Nelson, E., Torres, M., et al. (2015). Advancing the science of microbial symbiosis to support invasive species management: a case study on *Phragmites* in the Great Lakes. *Front. Microbiol.* 6, 95. <https://doi.org/10.3389/fmicb.2015.00095>.
123. Overwater, M., Pelletier, D., and Steel, M. (2023). The expected loss of feature diversity (versus phylogenetic diversity) following rapid extinction

- at the present. *J. Math. Biol.* 87, 53. <https://doi.org/10.1007/s00285-023-01988-4>.
124. Rhymer, J.M., and Simberloff, D. (1996). Extinction by hybridization and introgression. *Annu. Rev. Ecol. Syst.* 27, 83–109. <https://www.jstor.org/stable/2097230>.
 125. Razgour, O., Forester, B., Taggart, J.B., Bekaert, M., Juste, J., Ibáñez, C., Puechmaile, S.J., Novella-Fernandez, R., Alberdi, A., and Manel, S. (2019). Considering adaptive genetic variation in climate change vulnerability assessment reduces species range loss projections. *Proc. Natl. Acad. Sci. USA* 116, 10418–10423. <https://doi.org/10.1073/pnas.1820663116>.
 126. Jordan, C.Y., Lohse, K., Turner, F., Thomson, M., Gharbi, K., and Ennos, R.A. (2018). Maintaining their genetic distance: Little evidence for introgression between widely hybridizing species of *Geum* with contrasting mating systems. *Mol. Ecol.* 27, 1214–1228. <https://doi.org/10.1111/mec.14426>.
 127. Leinonen, P.H., Helander, M., Vázquez-de-Aldana, B.R., Zabalgoitia, I., and Saikkonen, K. (2019). Local adaptation in natural European host grass populations with asymmetric symbiosis. *PLoS One* 14, e0215510. <https://doi.org/10.1371/journal.pone.0215510>.
 128. Koonin, E.V. (2016). Horizontal gene transfer: essentiality and evolvability in prokaryotes, and roles in evolutionary transitions. *F1000Res.* 5, F1000 Faculty Rev-1805. <https://doi.org/10.12688/f1000research.8737.1>.
 129. Hall, R.J. (2016). Hybridization helps colonizers become conquerors. *Proc. Natl. Acad. Sci. USA* 113, 9963–9964. <https://doi.org/10.1073/pnas.1611222113>.
 130. Milner, D.S., Attah, V., Cook, E., Maguire, F., Savory, F.R., Morrison, M., Müller, C.A., Foster, P.G., Talbot, N.J., Leonard, G., and Richards, T.A. (2019). Environment-dependent fitness gains can be driven by horizontal gene transfer of transporter-encoding genes. *Proc. Natl. Acad. Sci. USA* 116, 5613–5622. <https://doi.org/10.1073/pnas.181599411>.
 131. Goulet, B.E., Roda, F., and Hopkins, R. (2017). Hybridization in plants: Old ideas, new techniques. *Plant Physiol.* 173, 65–78. <https://doi.org/10.1104/pp.16.01340>.
 132. Prüfer, K., Racimo, F., Patterson, N., Jay, F., Sankararaman, S., Sawyer, S., Heinze, A., Renaud, G., Sudmant, P.H., de Filippo, C., et al. (2014). The complete genome sequence of a Neanderthal from the Altai Mountains. *Nature* 505, 43–49. <https://doi.org/10.1038/nature12886>.
 133. Schaefer, N.K., Shapiro, B., and Green, R.E. (2016). Detecting hybridization using ancient DNA. *Mol. Ecol.* 25, 2398–2412. <https://doi.org/10.1111/mec.13556>.
 134. Puigbò, P., Wolf, Y.I., and Koonin, E.V. (2019). Genome-wide comparative analysis of phylogenetic trees: The prokaryotic forest of life. *Methods Mol. Biol.* 1910, 241–269. https://doi.org/10.1007/978-1-4939-9074-0_8.
 135. Alves, F.C., Granato, Í.S.C., Galli, G., Lyra, D.H., Fritsche-Neto, R., and de los Campos, G. (2019). Bayesian analysis and prediction of hybrid performance. *Plant Methods* 15, 14. <https://doi.org/10.1186/s13007-019-0388-x>.
 136. Puigbò, P., Wolf, Y.I., and Koonin, E.V. (2010). The tree and net components of prokaryote evolution. *Genome Biol. Evol.* 2, 745–756. <https://doi.org/10.1093/gbe/evq062>.